

INKJET PRINTER

JV330 Series
CJV330 Series
TS330-1600
UCJV330 Series

Operation Manual

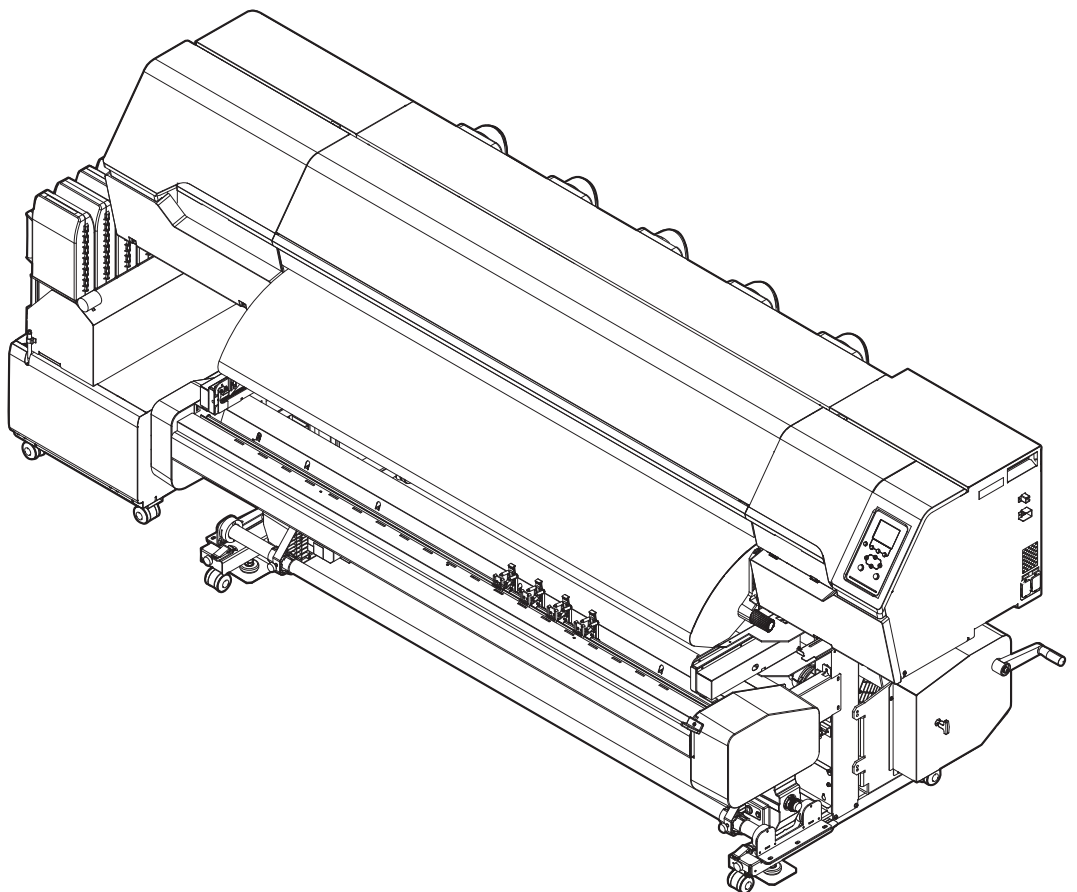

You can also download the latest manual from official website.

MIMAKI ENGINEERING CO., LTD.

<https://mimaki.com/>

D203599-23
Original instructions

Operation Manual

TABLE OF CONTENTS

Introduction	7
To Ensure Safe Use	9
Symbols	9
Usage Precautions	10
Notes on Handling Ink or any Other Liquid Used with the Machine	15
Ink Specifications	16
Restrictions Concerning the Expiration Date of Ink Used in the Machine	17
Restrictions Concerning Ink Set Changes	17
Installation Precautions.....	18
Installation Space	19
When Relocating This Machine	20
Safety Interlocks	21
Warning Labels.....	22

Chapter 1 Before Use

1.1 Part Names and Functions	26
Front	26
Rear and Right Side View.....	28
Ink Supply Unit.....	29
Carriage	30
Station.....	30
Platen.....	30
Pinch Rollers and Grit Rollers.....	31
Media Sensor.....	31
Power Supply Switch	32
Operating Panel.....	33
1.2 Connecting the Power Cable	37
Turning On the Power.....	37
Turning Off the Power.....	38
1.3 Connecting a PC to the Product	40
Using a LAN Cable	40
Using a USB Cable.....	41
1.4 System Configuration	42
Installing the Mimaki Driver.....	43
Installing RIP Software	43
Obtaining Color Profiles.....	43
Setting Up RIP Software.....	43
1.5 Ink Replacement Method.....	45
When Ink Near End is Displayed	45
When Ink End is Displayed.....	45
Replacing Ink	46

Chapter 2 Printing

2.1 Print Process	58
-------------------------	----

2.2 Adjusting Print Head Height.....	61
2.3 Adjust the Pinch Roller Positions.....	63
1,600 mm Size.....	64
1,300 mm Size.....	65
2.4 Loading the Media.....	66
Media.....	66
Take-up unit.....	67
Feeding unit.....	72
Media Changer.....	74
Loading the Roll Media.....	76
Setting Leaf Media.....	81
Registering the Media.....	85
2.5 Setting the Pressure and Number of Pinch Rollers to Use.....	87
2.6 Setting the Heater Temperature.....	89
2.7 Test Printing.....	90
Changing the Layout Direction for Test Printing.....	90
Checking White Ink Ejection.....	91
Ejection Failures.....	91
2.8 Head Cleaning.....	92
2.9 Feed Correction.....	93
Feed Correction Procedure.....	93
2.10 Correcting the Drop Position.....	95
Drop Position Correction Procedure.....	95
2.11 Preparing RIP data.....	97
2.12 Printing.....	99
Changing the Origin.....	99
Starting Printing.....	100
Stopping Printing (Data Clear).....	101
2.13 Cutting the media.....	102
V-shaped Cutting.....	103

Chapter 3 Cutting

3.1 Cutting Process.....	106
3.2 Installing Cutting Tools.....	108
Using the Cutter.....	108
Using a Pen.....	112
3.3 Setting the Cutting Conditions.....	116
3.4 Test Cutting.....	117
3.5 Cutting the Cutting Data.....	118
Changing the Origin.....	118
Starting Cutting.....	118
Stopping Cutting (Data Clear).....	119
Retracting the Cutter Unit.....	119

Chapter 4 Cutting Data with Register Marks

4.1 Process for Cutting Data with Register Marks	122
4.2 Creating Register Marks	124
Register Marks.....	124
Register Mark Size	125
Spacing Between Register Marks.....	126
Reading Range of Register Marks.....	127
No-Plotting Areas Around Register Marks.....	128
Combined Operations of Printing and Cutting	129
4.3 Setting Mark Detection Conditions	130
4.4 Detecting the Position of the Register Mark Origin.....	131
4.5 ID Cut Process.....	132
When using the XY slitter	133

Chapter 5 Using the XY Slitter

5.1 XY Slitter.....	136
XY Clamp Lever.....	137
X Cutter.....	138
Using the Tension Bar	139
Media Chute	139
5.2 Slitting Simultaneously With Printing	143
Enable the XY Slitter.....	144
Loading the Media	144
Printing guide (slit) line	148
Mounting the X cutter.....	151
Printing RIP data.....	155
5.3 Slitting the Print Media Afterwards.....	157
Disable the XY Slitter	159
Setting the Media Width Detection Type to AUTO	159
Loading the Media	159
Printing guide (slit) line	159
Printing RIP data.....	159
Enable the XY Slitter.....	160
Positioning printed media	160
Detecting slitting marks.....	161
Mounting the X cutter and slitting	164
5.4 Troubleshooting	170
If a Media Jam Occurs in the XY Slitter	170
If the Y Slit Position is Offset	171

Chapter 6 Setup

6.1 Media Setting Menu.....	174
6.2 Maintenance Menu	177
Registering Nozzle Recovery	179
Nozzle Check.....	181

6.3 Function Setting Menu.....	182
6.4 Environment Setting Menu	185
6.5 Machine Status Menu	187
6.6 Cutting Menu	188
Copying the Last Data	190
Preventing Uncut Media	192

Chapter 7 Maintenance

7.1 Maintenance Precautions	194
7.2 Maintenance Methods	195
Maintenance Items and Timing.....	195
Ink Maintenance	197
Cap Rubber Cleaning	198
Carriage Underside Cleaning	198
Cloth Wiper Area Cleaning	200
NCU Cleaning.....	200
DAS (Automatic Correction Function) Sensor Cleaning	202
Ink Discharge Channel Cleaning	203
Media Sensor Cleaning	205
Media Cutter Cleaning	206
Media Holder Cleaning	207
Jam Sensor Detecting Plate Cleaning	208
Platen Cleaning	209
Cover (Exterior) Cleaning	209
Cleaning the Mist Filter	210
Blowing Fan Filter Cleaning.....	211
When this Printer is Left Unused for a Long Time	213
7.3 Replacement of Consumable Item	217
Consumable Item Replacement Timing.....	217
Cloth Wiper Replacement.....	219
Cap Replacement.....	223
Replacing the Absorber Around the Station	225
Exhaust Fan Filter Replacement	229
Blowing Fan Filter Replacement.....	230
Pinch Roller Replacement	231
Media Holder Replacement	232
Media Cutter Replacement	234
Y Cutter Replacement (XY Slitter)	236
X Cutter Replacement (XY Slitter)	237
Media Edge Guide Film Replacement	239
Ink Supply Unit Ink Absorber Replacement	240
Waste Ink Tank Replacement.....	242
Mist Filter Replacement	245
UV-LED Glass Replacement	246
Cutter for Cutting Machine	247
Pen Line Replacement	247
Bottle Cap Replacement.....	248

Chapter 8 Troubleshooting

8.1 Troubleshooting	250
The power does not turn on.....	250
Printing is not possible.....	250
The media jams or the media is dirty.....	250
Image defects occur.....	251
The heater temperature does not rise to the specified value.....	256
The ink has leaked out.....	256
The light-blocking cover comes off.....	256
Abnormal noise occurs during cleaning.....	257
Cutting Related	258
8.2 To Stop Circulation Operation	263
8.3 Problems Causing Messages to Appear	264
Warning Messages	264
Ink error	266
Error Message	267
SYSTEM HALT	278

Chapter 9 Appendix

9.1 Specifications.....	280
9.2 Specifications (Cutting).....	284
9.3 Specifications (XY Slitter)	285
9.4 Options	286
Relay Box	287
Ionizer	288
Static-Cling Prevention Sheet Kit.....	291
Deodorizing fan unit.....	294
Proofing Light.....	300
UCJV330 Heater Unit	302
TP Ink Heater Unit	305
9.5 LICENSE Library	308

Introduction

Thank you for purchasing the Inkjet printer 330 Series.

Read this operating manual ("this document" hereinafter) thoroughly and make sure you understand its contents to ensure safe and correct use of the product.

Please note that the illustrations contained in this manual are intended to show functions, procedures, or operations and may sometimes differ slightly from the actual machine.

Adobe, the Adobe logo, Acrobat, Illustrator, Photoshop, and PostScript are the trademarks or registered trademarks of Adobe Incorporated in the United States and other countries.

RasterLink and TxLink are trademarks or registered trademarks of Mimaki Engineering Co. Ltd. in Japan and other countries.

Other company and product names mentioned herein are the trademarks or registered trademarks of the respective companies in Japan and in other countries.

Unauthorized reproduction of any portion of this document is strictly prohibited.

© 2022 MIMAKI ENGINEERING Co., Ltd.

● DISCLAIMERS

- MIMAKI ENGINEERING REJECTS ALL LIABILITY FOR DAMAGE ARISING DIRECTLY OR INDIRECTLY FROM THE USE OF THE 330 Series ("THIS MACHINE" HEREINAFTER), WHETHER OR NOT THE PRODUCT IS FAULTY.
- MIMAKI ENGINEERING REJECTS ALL LIABILITY FOR DAMAGE, DIRECT OR INDIRECT, TO MATERIALS CREATED WHILE USING THIS MACHINE.
- USING THIS MACHINE IN CONJUNCTION WITH DEVICES OTHER THAN THOSE RECOMMENDED BY MIMAKI ENGINEERING MAY RESULT IN FIRE OR ACCIDENTS. SUCH INCIDENTS ARE NOT COVERED BY THE PRODUCT WARRANTY. MIMAKI ENGINEERING REJECTS ALL LIABILITY FOR DAMAGE, DIRECT OR INDIRECT, ARISING FROM SUCH INCIDENTS.
- USE ONLY GENUINE MIMAKI ENGINEERING INK AND MAINTENANCE LIQUID. USE OF OTHER PRODUCTS MAY RESULT IN FAILURES OR REDUCE PRINT QUALITY. SUCH INCIDENTS ARE NOT COVERED BY THE PRODUCT WARRANTY. MIMAKI ENGINEERING REJECTS ALL LIABILITY FOR DAMAGE, DIRECT OR INDIRECT, ARISING FROM SUCH INCIDENTS.
- DO NOT ATTEMPT TO REFILL THE INK PACKS WITH UNAUTHORIZED INK. SUCH INCIDENTS ARE NOT COVERED BY THE PRODUCT WARRANTY. MIMAKI ENGINEERING REJECTS ALL LIABILITY FOR DAMAGE, DIRECT OR INDIRECT, ARISING FROM SUCH INCIDENTS.
- AVOID USING UV-LED UNITS OR UV POWER SUPPLY UNITS OTHER THAN THOSE SPECIFIED BY MIMAKI ENGINEERING. USING DEVICES OTHER THAN GENUINE MIMAKI ENGINEERING DEVICES MAY RESULT IN FAILURE, ELECTRIC SHOCK, OR FIRE. SUCH INCIDENTS ARE NOT COVERED BY THE PRODUCT WARRANTY. MIMAKI ENGINEERING REJECTS ALL LIABILITY FOR DAMAGE, DIRECT OR INDIRECT, ARISING FROM SUCH INCIDENTS.

● TV and radio interference



- The machine emits high-frequency electromagnetic radiation while operating. Under certain circumstances, this may result in TV or radio interference. We make no guarantee that this machine will not affect special radio or TV equipment.
-

If radio or TV interference occurs, check the radio or TV reception after turning off the machine. If the interference disappears when the power is turned off, the machine is likely to be the cause of the interference.

Try any of the following solutions or combinations of these solutions:

- Change the orientation of the TV or radio antenna to find a position where interference does not occur.
- Move the TV or radio away from this machine.
- Plug the TV or radio into a power outlet on a power circuit other than the power circuit to which this machine is connected.

● FCC (Federal Communications Commission) regulations

The machine has been tested and certified to comply with restrictions applying to Class A digital devices under Part 15 of the FCC regulations. These restrictions are designed to provide suitable protection from harmful interference when the printer is used in commercial environments.

This product may generate, use, or emit radio frequency energy and may cause harmful interference with radio communications if not installed or used in accordance with the operating manual.

Use of this product in residential areas may cause harmful interference. If so, the user is responsible for rectifying such interference.











- Use only the cables recommended by Mimaki Engineering when connecting to the machine. Use of other cables may cause the product to exceed the restrictions stipulated by FCC regulations. To maintain compliance with FCC regulations, use the cables recommended by Mimaki Engineering.
-

To Ensure Safe Use

Symbols

In this manual, the symbols indicate and explain precautions. Make sure you fully understand the meaning of each symbol and use the machine safely and correctly.

Explanation		
	Warning	Indicates a potential hazard that may result in death or serious injury if handled improperly or if instructions are disregarded.
	Caution	Indicates a potential hazard that may result in minor or moderate injury if handled improperly or if instructions are disregarded.
	Notice	Indicates a potential hazard that may result in property damage if handled improperly or if instructions are disregarded.
	Warning sign	Indicates something that requires attention. Warning specifics are drawn inside the symbol.
	Mandatory action sign	Indicates an action that must be carried out. The specifics of the mandatory action are drawn inside the symbol.
	Prohibition sign	Indicates a prohibited action. The specifics of the prohibited action are drawn inside the symbol.
	Important	Indicates important information related to use of this machine.
	Tip	Indicates useful reference information.
	Reference information	Indicates the corresponding page for related information.

Explanation of model icons



- Model icons are shown for items where differences exist between models.

JV
CJV
TS
UCJV

- Model icons are not shown for items where the details are the same for all models.

Usage Precautions

● In the event of abnormal conditions

WARNING



- In the event of abnormal conditions such as smoke or unusual odor, turn off the main power immediately and unplug the power cable. Continuing to use the machine under these conditions may result in failure, electric shock, or fire. Once you have confirmed that smoke is no longer being emitted, contact your local dealer or our service office. Never attempt to repair the machine yourself, which is hazardous.

CAUTION



- Immediately wipe off any ink, maintenance liquid, waste ink, or other liquid used with the product that comes into contact with your skin. Then wash using soap, and rinse with plenty of water. Failure to wash off ink may result in skin inflammation. If your skin becomes irritated or painful, seek medical attention immediately.
- If ink, maintenance liquid, waste ink, or any other liquid used in the product comes into contact with your eyes, rinse immediately with plenty of clean water. Rinse for at least 15 minutes. If you wear contact lenses and they can be easily removed, remove after rinsing for at least 15 minutes with clean water. Be sure to also rinse the undersides of your eyelids. Failure to rinse off ink may result in blindness or impaired vision. If your eyes become irritated or painful, seek medical attention immediately.
- If ink, maintenance liquid, waste ink, or any other liquid used in the product enters your mouth or is swallowed, gargle with water immediately. Do not induce vomiting. Seek medical attention promptly. Inducing vomiting may cause liquid to enter the airway.
- If a large amount of vapor is inhaled, move to a well-ventilated area, keep warm, and rest in a posture that allows easy breathing. If the condition does not improve, seek medical attention promptly.

NOTICE



- If an ink leak occurs, turn off the main power immediately and unplug the power cable. Then, contact your local dealer or our service office.

● Power supply precautions

⚠ WARNING



- Use the power cable provided. Otherwise there is a risk of failure, electric shock, or fire. The power cable provided is exclusive for the machine, and must not be used for other electrical equipment.
- Always hold the plug when removing the power cable. Pulling out the power cable may damage the cable, leading to failure, electric shock, or fire.
- Do not use the machine with dust accumulated on the power plug. Otherwise there is a risk of failure, electric shock, or fire.
- Take care to prevent metals from touching the power plug blades. Otherwise there is a risk of failure, electric shock, or fire.
- Do not damage or modify the power cable. Do not place heavy objects on, heat or stretch it. Doing so may damage the cable, leading to electric shock or fire.
- Do not use extension cords or power strips. Otherwise there is a risk of failure, electric shock, or fire.
- Do not use the power cable if it is damaged or broken or if the core wire is exposed. Otherwise there is a risk of failure, electric shock, or fire.
- Do not handle the power plug with wet hands. Disregarding this precaution may result in electric shock.



- Plug the power cable plug into a grounded power outlet. Otherwise there is a risk of failure, electric shock, or fire.
- When installing electrical outlets, perform grounding work to prevent electric shock. All electrical work (Class C grounding work; formerly Type 3 grounding work) must be handled by a licensed electrician.

NOTICE



- Do not turn off the main power supply. Turning off the main power supply will disable the automatic maintenance function (including nozzle clogging prevention function and ink discharge channel cleaning function). This increases the risk of ejection failures (such as nozzle clogging or deflection).

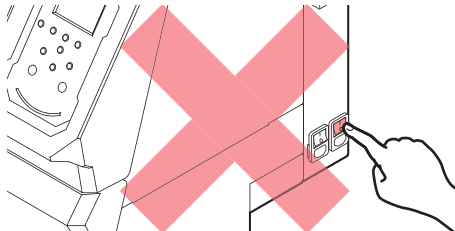

- Use the machine with a power supply that meets specifications.
- Be sure to plug the power cable into a power outlet close to the machine. Insert the power plug blade securely.
- When connecting the power cable, check the input voltage of the power outlet and the capacity of the breaker. Also, connect each cable to a separate power source with an independent breaker. Connecting to power outlets linked with the same breaker will cause the breaker to trip.

● **Caution regarding moving parts**

 **CAUTION**



- Keep parts of the body such as the face and hands away from moving parts. Also keep clothing (e.g., loose clothing and accessories) that may impede work away from the machine. Failure to do so may result in injury.



- Long hair should be tied back. Failure to do so may result in injury.

● **Do not disassemble or repair**

 **WARNING**



- Do not attempt to disassemble or repair this machine. Otherwise there is a risk of failure, electric shock, or fire.

● **Handling the cutter**

 **CAUTION**



- Avoid touching the cutter blade. Failure to do so may result in injury.
- Do not shake or swing the cutter holder. Doing so may cause the blade to come off.

● **Heater**



 **CAUTION**



- The heater becomes extremely hot. Do not touch with bare hands.

NOTICE



- Condensation may form on the print head nozzle surface depending on the ambient temperature and humidity. The formation of condensation may cause ejection failures (e.g., nozzle clogging or deflection). Perform head cleaning if any ejection failures (e.g., nozzle clogging or deflection) occur during printing.  ["Head Cleaning"\(P. 92\)](#)
Set the platen heater to a temperature not exceeding 35 °C, and ensure that the ambient temperature is within the permissible operating temperature range (20 to 30 °C).  ["Installation Precautions"\(P. 18\)](#)

● **Ultraviolet light (UV) and the UV-LED unit**

 **WARNING**



- Do not place combustibles under the UV-LED unit, and do not cover it with paper or cloth. There is a risk of fire or burns.
- Small amounts of ultraviolet light may leak from the UV-LED unit. Wear UV safety glasses, face shields, masks, gloves, and long-sleeved clothing to protect the eyes and skin from ultraviolet light.
 - (1) Exposure to ultraviolet light may result in skin inflammation. Even if no inflammation occurs, extended or repeated exposure may lead to chronic problems.
 - Acute problems: Inflammation
 - Chronic problems: Skin cancer, wrinkles, blotches
 - (2) Looking directly at the lamp while the lamp is on may result in eye pain or damage to eyesight. Even if no eye pain occurs, extended or repeated exposure may lead to chronic problems.
 - Acute problems: Ultraviolet keratitis, conjunctivitis, discomfort, pain, watery eyes
 - Chronic problems: Pterygium, cataracts

CAUTION

- The UV-LED unit becomes extremely hot. Be careful not to touch the LED after it has been turned off until it has sufficiently cooled.



- Do not expose the skin or eyes directly or indirectly to light from the UV-LED unit. The UV-LED unit emits ultraviolet (UV) light. Skin or eye exposure may result in inflammation.



- Be sure to use the UV safety glasses provided. Disregarding this precaution may result in eye pain or damage to eyesight.

NOTICE

- Avoid scratching or subjecting the UV-LED unit to excessive force. Disregarding this precaution may result in deformation or failure of the unit.
- Avoid touching the glass on the underside of the UV-LED unit with bare hands. Disregarding this precaution may impair UV ink curing. If the glass becomes dirty, wipe clean using a soft, clean cloth soaked with ethanol. Be careful to keep ethanol from splashing on the covers or other parts while cleaning. Disregarding this precaution may result in deformation or failure of the unit.

● Other usage precautions

WARNING

- Keep children away from the machine.

NOTICE

- Do not pull the media when the clamp lever is lowered (the media is clamped). Doing so may damage the machine.



- The underside of the media may be soiled depending on how the printed media has been stored (due to weight when laying printed media rolls horizontally, for example) and the media type. Perform a test beforehand to check that the media does not transfer ink to the underside of the adjacent media.

● **Disposing of the product**

 **CAUTION**



- Please contact your local retailer or service agent.
- When disposing of the product yourself, contact an industrial waste disposal operator or dispose of the product in accordance with local laws and regulations.

Notes on Handling Ink or any Other Liquid Used with the Machine

Precautions regarding ink, maintenance liquid, or other liquids used with this machine are included with the containers. Thoroughly read them and make sure you understand the contents.



- Be sure to read the safety data sheet (SDS) before use. <https://mimaki.com/supply/sds/>

CAUTION



- Pay close attention to ventilation and be sure to wear safety glasses, gloves, and a mask when handling ink, maintenance liquid, waste ink, or other solutions used with the machine. Leaking ink may adhere to the skin or get into the eyes or mouth.



- Do not subject cases containing ink to strong shock or violent shaking. Do not attempt to refill the ink. Leaking ink may adhere to the skin or get into your eyes or mouth.



- Do not disassemble cases containing ink. Leaking ink may adhere to the skin or get into your eyes or mouth.



- Do not store ink, maintenance liquid, or other liquids used with the machine in locations where children may enter.



- When disposing of ink, maintenance liquid or other liquid used with the product, or containers or non-woven fabric contaminated with ink or other liquid, contact an industrial waste disposal operator or dispose of the product in accordance with the local laws and regulations.

NOTICE



- Do not store ink, maintenance liquid, or other liquids used with the machine in locations exposed to direct sunlight.
- Do not store ink, maintenance liquid, or other liquids used with the machine in environments where cutting fluid or other volatile substances (such as amines or modified amine alcohol) are present in significant quantities. Storage in such places increases the risk of failure or ejection failures (e.g., nozzle clogging or deflection).
- Do not use ink, maintenance liquid, or other liquids used with this machine with other printers. Doing so may cause failure.



- Store ink, maintenance liquid, and other liquids used with the machine at a height of not more than 1 m from the floor level. Otherwise there is a risk of scattering if the containers fall.
- Store in tightly sealed containers.
- Store in a cool, dark place.
 - (1) Store ink in a place where ink does not freeze. Using defrosted ink may deteriorate ink constituents and reduce print quality.
 - (2) When ink is moved from a cold place to a warm place, leave it in the environment where the machine is installed for at least three hours before using it.
 - (3) Open the container just before installing it, and use it up as quickly as possible. If it is opened and left for an extended period of time, print quality may be reduced.



- Do not touch the metal parts of the ink IC chip. Static electricity may damage the ink IC chip, and dirt or damage may cause the ink IC chip read error.



- Printing is not possible when different types of ink IC chips are used.
- If the ink bottle mounted on the machine is dented, it may still be used.

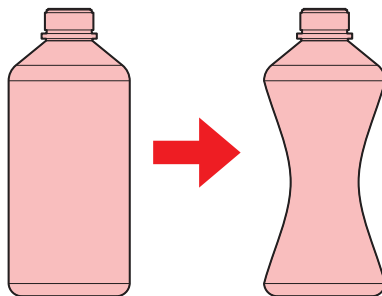

Ink Specifications

Item	JV330 Series, CJV330 Series	UCJV330 Series	TS330-1600	
Type	Special solvent ink (Mimaki Engineering product)	Special UV curing ink (Mimaki Engineering product)	Special sublimation transfer ink / special pigment transfer ink (Mimaki Engineering product)	
Color	Cyan (C) Magenta (M) Yellow (Y) Black (K) Light cyan (Lc) Light magenta (Lm) Light black (Lk) Orange (Or) White (W)	Cyan (C) Magenta (M) Yellow (Y) Black (K) Light cyan (Lc) Light magenta (Lm) White (W) Clear ink (CI)	Blue (BL) Magenta (M) Yellow (Y) Black (K) Light blue (Lbl) Light magenta (Lm) Light black (Lk) Fluorescent pink (FP) Fluorescent yellow (FY) Cyan (C) Red (R) Green (GR)	
Form	Aluminum pack	Bottle	Aluminum pack, ink tank ^{*2}	
Ink capacity ^{*1}	2,000 ml, 1,000 ml, 500 ml	1,000 ml	2,000 ml, 10,000 ml ^{*2}	
Expiration date	As indicated on the ink pack. However, after opening, it should be consumed within three months, even if before the expiration date.	As indicated on the ink bottle. However, after opening, it should be consumed within three months, even if before the expiration date.	As indicated on the ink pack. However, after opening, it should be consumed within one month, even if before the expiration date.	
Storage temperature ^{*3}	When stored	10 to 35 °C (daily mean temperature) • However, not more than 1 month at 30 °C	5 to 30 °C (daily mean temperature) • However, not more than 1 month at 30 °C	10 to 35 °C (daily mean temperature)
	During transportation	1 to 40 °C	1 to 60 °C	0 to 40 °C

Item	JV330 Series, CJV330 Series	UCJV330 Series	TS330-1600
	<ul style="list-style-type: none"> • However, not more than 120 hours at 60 °C, and not more than 1 month at 40 °C • Where possible, avoid storing in cold locations below 0 °C and hot locations above 40 °C. 	<ul style="list-style-type: none"> • However, not more than 120 hours at 60 °C, and not more than 1 month at 40 °C • Where possible, avoid storing in cold locations below 0 °C and hot locations above 40 °C. 	

*1. Depends on ink type.

*2. Depends on options.

*3. Ink quality may deteriorate if stored outside this temperature range.

Restrictions Concerning the Expiration Date of Ink Used in the Machine

Example: When the expiration date is April 20xx

- May 20xx: Replace with new ink or use up as quickly as possible. Printing is possible.
- June 20xx: Replace with new ink or use up as quickly as possible. Printing is possible.
- July 20xx: Printing is not possible.



- The message appears on the display.



- The ink expiration date is indicated on the ink container. Expired ink may cause ejection failures or alter the color tone. Printing is possible even if the ink has passed its expiration date. Nevertheless, we recommend replacing with new ink or using up as quickly as possible.

Restrictions Concerning Ink Set Changes

The ink set cannot be changed for the following pattern combinations:

- Solvent ink:
 - 6-color, W (C, M, Y, K, Lc, Lm, W) -> 8-color (C, M, Y, K, Lc, Lm, Lk, Or)
 - 8-color (C, M, Y, K, Lc, Lm, Lk, Or) -> 6-color, W (C, M, Y, K, Lc, Lm, W)

Installation Precautions

WARNING



- Do not install the machine in a place close to fire. Doing so may result in inflammation of solvent ink.
- Do not place flower vases, pots, cups, containers containing cosmetics, chemicals or water, or small metal items on or close to the machine. If they enter the machine, there is a risk of failure, electric shock, or fire.



- Do not install this machine in humid locations or locations where it may be exposed to splashing water. Otherwise there is a risk of failure, electric shock, or fire.



- Do not install the machine in a place where children may enter.

CAUTION



- A ventilation system must be provided if this machine is installed in a poorly ventilated area or sealed room.
- Be sure to observe the following points when installing an extractor outlet:
 - (1) The extractor outlet must be installed in accordance with applicable local EHS (environmental, health, and safety) guidelines.
 - (2) If the extractor outlet is fitted with a shutoff valve, the valve must be open when this machine is in use.

NOTICE



- Do not install this machine in locations where dust or powder is present. Failure or printing defects may result (e.g., nozzle clogging, deflection) if dust gets inside this machine.
- Do not install this machine in locations exposed to drafts (e.g., from air conditioning). Disregarding this precaution may result in dust or powder getting inside this machine.
- Do not install this machine in unstable locations or locations subject to vibration. This will increase the risk of failure or printing defects (e.g., nozzle clogging, deflection).
- Do not install this machine in locations exposed to direct sunlight.
- Do not install this machine in locations subject to sudden temperature changes. This will increase the risk of failure or printing defects (e.g., nozzle clogging, deflection).
- Do not install this machine in locations exposed to excessive noise from large machinery.
- Do not install this machine in locations where photographic fixing agents generate vapor or acid gas (e.g., acetic acid, hydrochloric acid) or locations filled with metal working fluids or highly volatile substances (e.g., amines, amine-modified alcohols). Malfunctions or printing defects may result (e.g., nozzle clogging, deflection) as print head ink is more likely to harden under such environments.



- Operating environment: 20 to 30 °C (68 to 86 °F), 35 to 65 %RH (no condensation)
- Temperature range in which accuracy is guaranteed: 20 to 25 °C (68 to 77 °F)

Installation Space

Provide the following space around the machine to allow safe and proper replacement of ink and media:

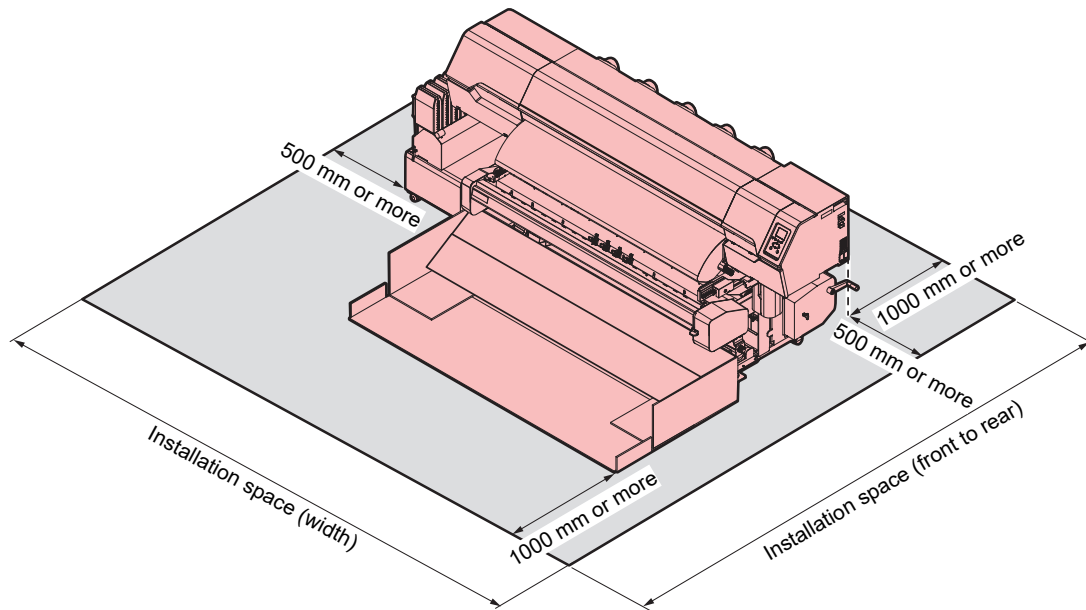

● JV330 Series

Size	160	130
Width ^{*1}	At least 4,170 mm (3,170 mm)	At least 3,920 mm (2,920 mm)
Depth ^{*1}	At least 4,050 mm (2,050 mm ^{*Including media chute})	
Height ^{*1}	(1,305 mm)	
Weight	368 kg	358 kg

*1. The figures in parentheses indicate machine dimensions.

● CJV330 Series

Size	160	130
Width ^{*1}	At least 4,170 mm (3,170 mm)	At least 3,920 mm (2,920 mm)
Depth ^{*1}	At least 4,050 mm (2,050 mm ^{*Including media chute})	
Height ^{*1}	(1,305 mm)	
Weight	373 kg	363 kg

*1. The figures in parentheses indicate machine dimensions.

● TS330-1600

Size	1600
Width ^{*1}	At least 4,170 mm (3,170 mm)
Depth ^{*1}	At least 2,820 mm (820 mm)
Height ^{*1}	(1,305 mm)
Weight	240 kg

*1. The figures in parentheses indicate machine dimensions.

● **UCJV330 Series**

Size	160	130
Width ^{*1}	At least 3,890 mm (2,890 mm)	At least 3,640 mm (2,640 mm)
Depth ^{*1}	At least 2,805 mm (805 mm)	
Height ^{*1}	(1,480 mm ^{*Excluding ink bottle})	
Weight	227 kg	217 kg

*1. The figures in parentheses indicate machine dimensions.

When Relocating This Machine

Contact your local dealer or our service office. Attempting to handle relocation yourself may result in failure or damage.

Safety Interlocks

The machine is equipped with interlocks to ensure safety during use.

Printing will abort if you open the covers while printing is underway. The RIP data will need to be resent.

- Safety interlock locations

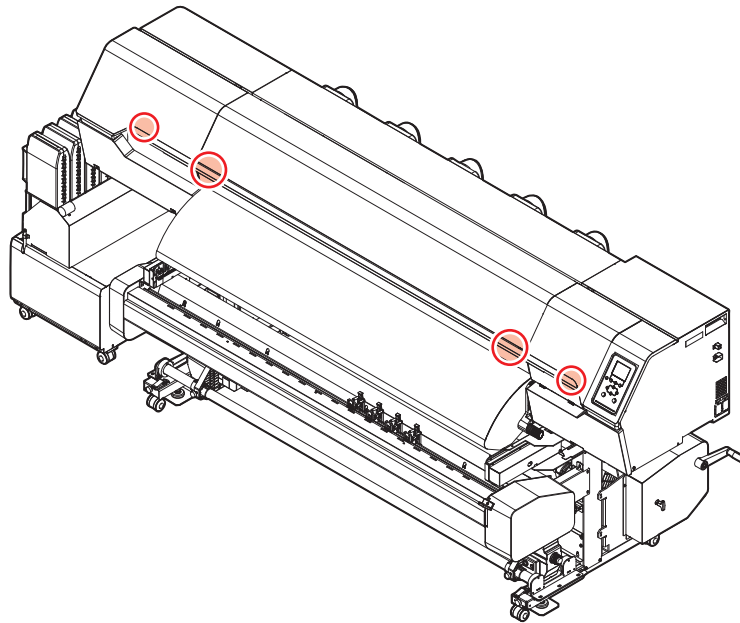







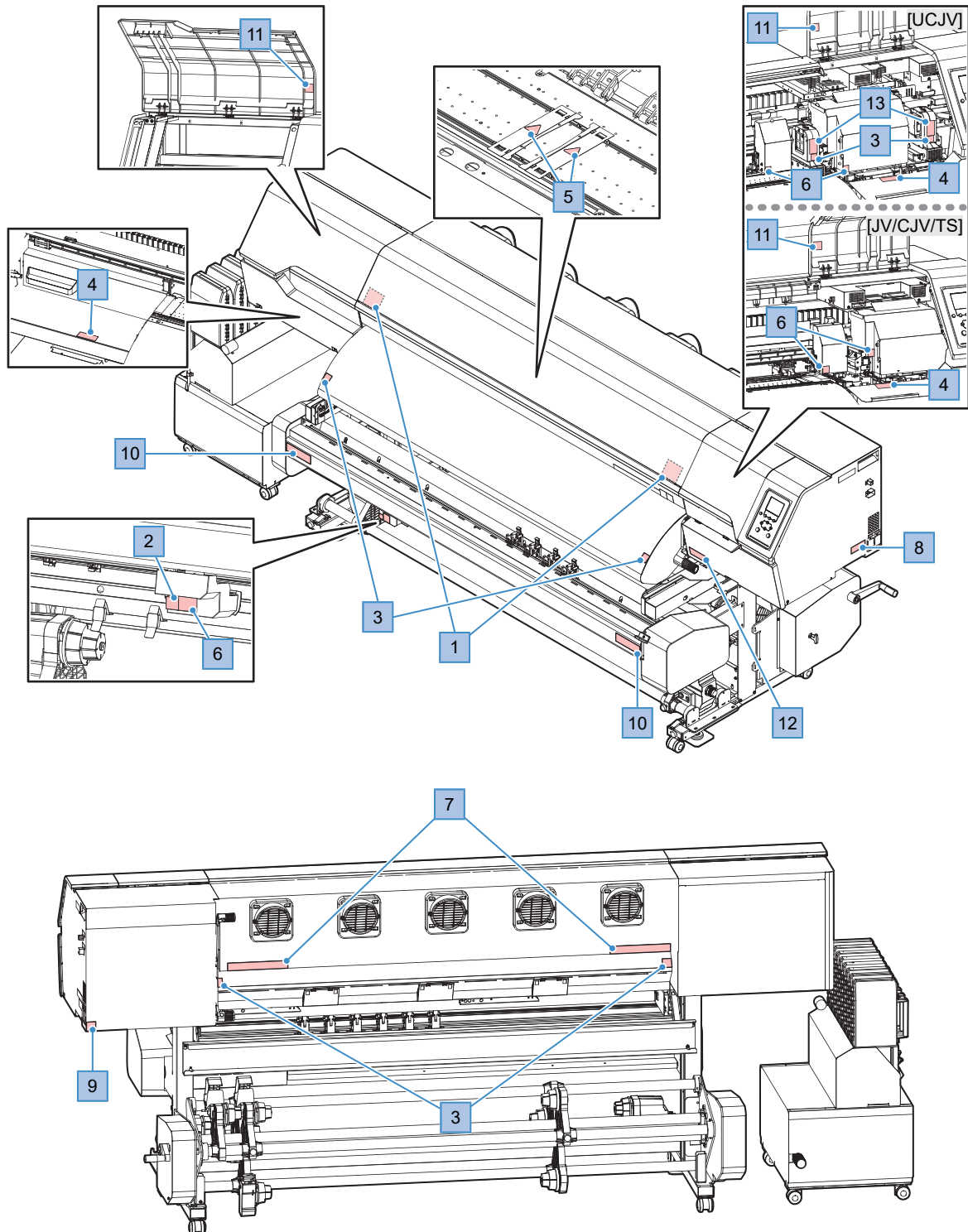



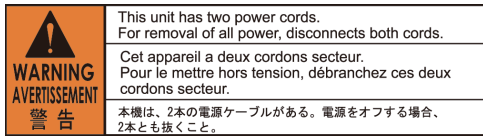

Warning Labels

Make sure you fully understand the details indicated on the various warning labels.

If any of the warning labels becomes dirty and illegible or peel off, contact your local dealer or our service office to request new warning labels.



No.	Order code	Label	Details
1	M910931		Beware of opening and closing parts. Injury may result if hands become trapped.
2	M907833		Indicates dangerous moving parts.
3	M903239		Indicates hot parts. <ul style="list-style-type: none"> JV/CJV: Pre-heater, post-heater TS: Post-heater UCJV: Preheater, UV-LED unit
4	M903330		Wear safety glasses and gloves while working.
5	M906144		Indicates hot parts. <ul style="list-style-type: none"> JV/CJV only
6	M903405		Beware of the cutter. <ul style="list-style-type: none"> JV: Carriage, XY carriage CJV/UCJV: Carriage, cutter unit, XY carriage TS: Carriage
7	M905811		Indicates dangerous moving parts.
8	M906031		Describes the power cable.
9	M907935		Indicates dangerous live parts.
10	M917747		Beware of the cutter. <ul style="list-style-type: none"> JV/CJV/UCJV only
11	M917991		Indicates illuminating LED hot parts.
12	M905935		Avoid touching the pinch roller lever. <ul style="list-style-type: none"> CJV/UCJV only

No.	Order code	Label	Details
13	M913419	 <p> WARNING AVERTISSEMENT 警告 </p> <p>  </p> <p> ULTRAVIOLET RADIATION RAYONS ULTRAVIOLETS 紫外線放射 紫外線照射 </p> <p> Ultraviolet Radiation. When exposed to ultraviolet light, there is a risk of skin cancer or burns. Rayonnement UltraViolet. Exposition dangereuse pour l'œil et la peau. Peut provoquer la cécité et des brûlures. 紫外線が照射されています。紫外線を浴びると失明や火傷の恐れがあります。 紫外線照射注意 紫外線照射会費不明 紫外線照射可能 </p>	Beware of ultraviolet light. <ul style="list-style-type: none"> • UCJV only

Chapter 1 Before Use



This chapter

This chapter describes information essential before use, such as part names.



Part Names and Functions	26	Connecting a PC to the Product	40
Front	26	Using a LAN Cable	40
Rear and Right Side View	28	Using a USB Cable	41
Ink Supply Unit	29	System Configuration	42
Carriage	30	Installing the Mimaki Driver	43
Station	30	Installing RIP Software	43
Platen	30	Obtaining Color Profiles	43
Pinch Rollers and Grit Rollers	31	Setting Up RIP Software	43
Media Sensor	31	Ink Replacement Method	45
Power Supply Switch	32	When Ink Near End is Displayed	45
Operating Panel	33	When Ink End is Displayed	45
Connecting the Power Cable	37	Replacing Ink	46
Turning On the Power	37		
Turning Off the Power	38		

1.1 Part Names and Functions

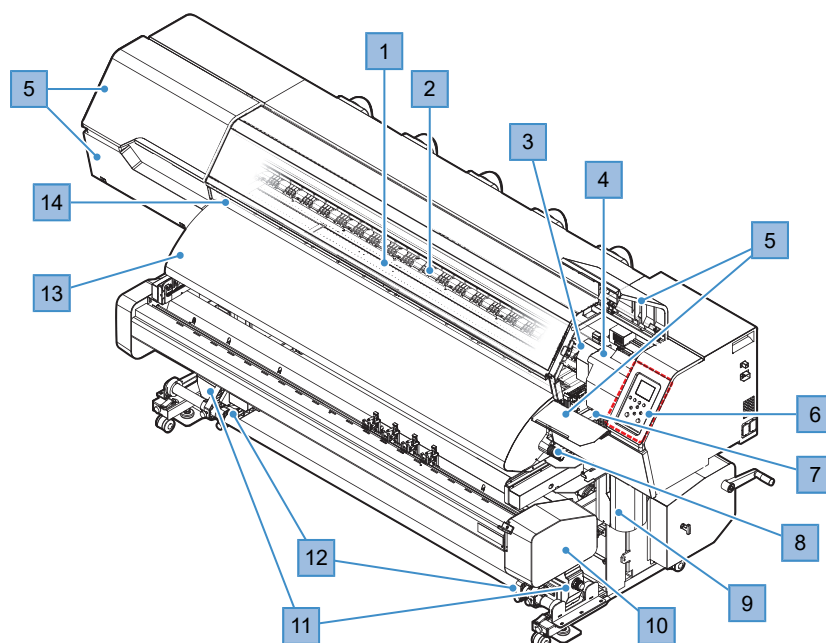
Front



No.	Name	Overview
1	Platen	Print area. "Platen"(P. 30) The platen on the JV and CJV is fitted with a heater to prevent ink bleeding (UCJV: option "UCJV330 Heater Unit"(P. 302)). Adjust the temperature setting to suit the type of media used. "Setting the Heater Temperature"(P. 89)
2	Pinch roller Grit roller	The pinch rollers and grit rollers are used to grip and feed the media. "Pinch Rollers and Grit Rollers"(P. 31)
3	Cutter unit *CJV/UCJV only	Holds a cutter and a pen for cutting. "Cutting"(P. 105) "Cutting Data with Register Marks"(P. 121)
4	Carriage	Consists of a print head, the jam sensor, and the media cutter. "Carriage"(P. 30) The UCJV is equipped with a UV-LED lamp, which cures the ink simultaneously with printing.
5	Maintenance cover	Open the cover to perform maintenance on locations such as the carriage underside. Printing and automatic maintenance are not possible while the covers are open.
6	Operating Panel	Includes operating keys and displays indicating various settings and other items. "Operating Panel"(P. 33)
7	Station	Includes caps for protecting the print head, wipers, and an NCU for monitoring print head nozzle conditions. "Station"(P. 30)
8	Clamp lever	Lowering the clamp lever secures the media. Raising the clamp lever releases the media. Linked to the clamp lever at the rear.
9	Waste Ink Tank	Contains the container for waste ink. "Waste Ink Tank Replacement"(P. 242)
10	XY slitter	Cuts the media to the specified size after printing. "Using the XY Slitter"(P. 135)

No.	Name	Overview
	*JV/CJV only * UCJV: Optional	
11	Take-up unit	Rolls up the printed roll media.  "Take-up unit"(P. 67)
12	Media Edge Guides * TS only * JV/CJV/UCJV: Option	In some cases, roll media may shift sideways and start to curl inwards. Using the media edge guides prevents the roll media from becoming offset.  "Using the Media Edge Guides"(P. 70)
13	Post-heater *JV/CJV/TS only * UCJV: Optional	Allows ink to dry after printing. Adjust the temperature setting to suit the type of media used.  "Setting the Heater Temperature"(P. 89)
14	Front cover	Open the cover for loading the media, performing maintenance on the area around the platen, and for replacing consumable items. Printing and automatic maintenance are not possible while the covers are open.

Rear and Right Side View

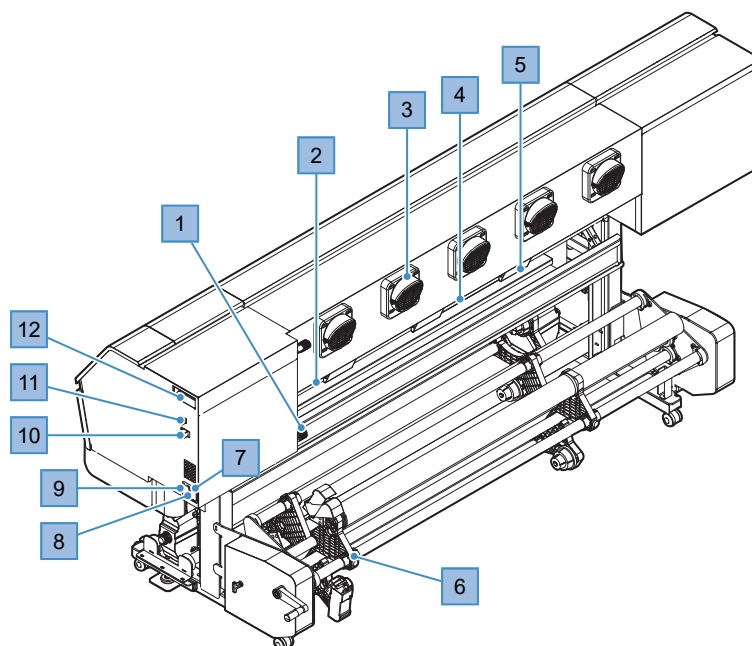

No.	Name	Overview
1	Clamp lever	Linked to the clamp lever at the front.
2	Media Sensor	Detects whether media is present. ☞ "Media Sensor"(P. 31)
3	Blowing fan *JV/CJV/TS only	Blows air to dry ink after printing.
4	Preheater *JV/CJV/UCJV only	Preheats the media before printing to suppress rapid temperature change. Adjust the temperature setting to suit the type of media used. ☞ "Setting the Heater Temperature"(P. 89)
5	Exhaust fan BOX	Discharges air for holding down the media.
6	Media Changer Feeding unit	Compatible with 2-inch and 3-inch paper cores. ☞ "Loading the Roll Media"(P. 76) <ul style="list-style-type: none"> • Media changer (JV/CJV (UCJV: option)): Allows up to three rolls of media to be loaded. ☞ "Media Changer"(P. 74) • Feeding unit (TS/UCJV): Allows one roll of media to be loaded.
7	AC inlet *TS/UCJV: One provided	The inlet at the rear (INLET1) is for the machine and the inlet at the front (INLET2) is for the heater. Use the power cable provided. ☞ "Connecting the Power Cable"(P. 37)
8	Main power switch	The main power supply for the machine. To prevent ejection failures attributable to the print head (e.g., nozzle clogging or deflection), do not turn off the main power supply. ☞ "Power Supply Switch"(P. 32) ☞ "Turning On the Power"(P. 37) ☞ "Turning Off the Power"(P. 38)
9	Heater power supply switch *JV/CJV only	The power supply for the heater is at the front. ☞ "Setting the Heater Temperature"(P. 89)
10	LAN port	Connects to PC via a LAN cable. ☞ "Using a LAN Cable"(P. 40)
11	USB port	Connects to PC via a USB interface cable. ☞ "Using a USB Cable"(P. 41)
12	Maintenance liquid cartridge *JV/CJV/TS only	Used to automatically feed maintenance liquid to the cap, and to prevent ink solidifying inside the ink discharge channel during maintenance.

Ink Supply Unit

[JV / CJV / TS]

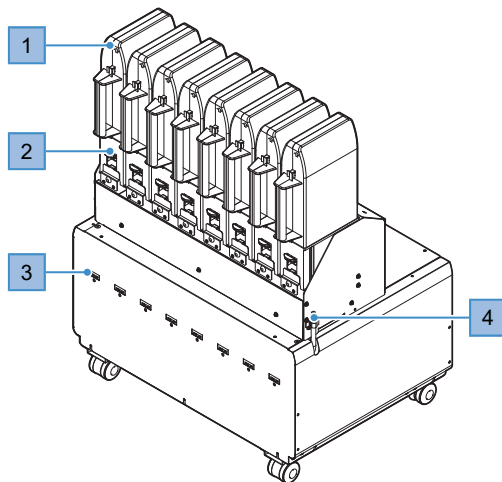

[UCJV]

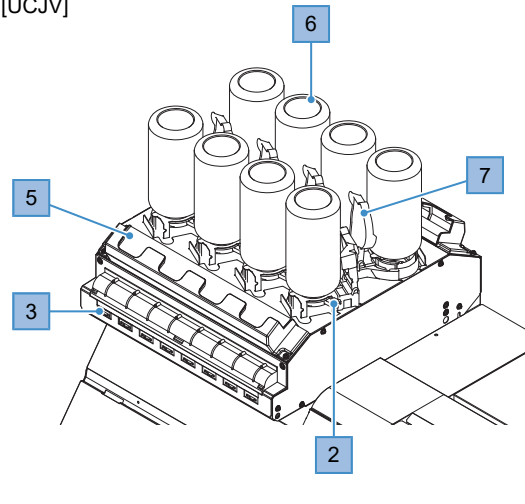

No.	Name	Overview
1	Ink Eco-case	The ink eco-cases are mounted here. P. 49
2	Ink lever	JV/CJV/TS: Push down the lever to remove the ink eco-cases. P. 46 UCJV: Slide the lever to the right to remove the ink bottles. P. 51
3	Ink IC chip slot	For inserting the ink IC chips provided with the ink. P. 49 This manages the ink information.
4	Ink leak check tube	If ink enters the tube, contact your local dealer or our service office.
5	Ink wipe pad	Pad for soaking up ink droplets from the ink bottle special caps. P. 51
6	Ink bottle	Mount the ink bottles. P. 55
7	Light-blocking cover	Cover to prevent light entering the ink supply unit when the ink bottles are removed.

Carriage

The carriage includes a print head for ejecting ink, and a jam sensor for stopping the carriage when media clogs. Printing occurs as ink is ejected while traversing left and right.

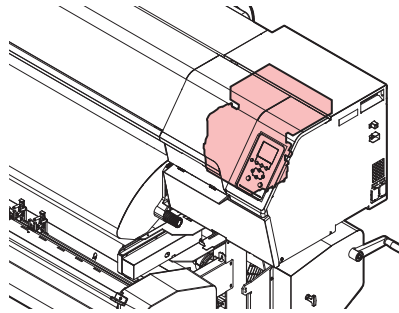

The UCJV is equipped with a UV-LED lamp, which cures the ink.



- Be sure to use the UV safety glasses provided. Disregarding this precaution may result in eye pain or damage to eyesight.

Station

The station includes caps for keeping the print head nozzle surface from drying out, a wiper required for print head maintenance, and an NCU for monitoring print head nozzle conditions.

The NCU (Nozzle Check Unit) automatically checks whether the nozzle is clogged. Setting various functions enables automatic print head cleaning or printing using other nozzles. [☞ "Registering Nozzle Recovery"\(P. 179\)](#)

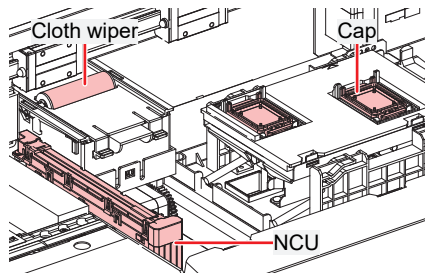

Platen

Print area. The platen secures the media under vacuum pressure. This also features a cutting slot for cutting the media.

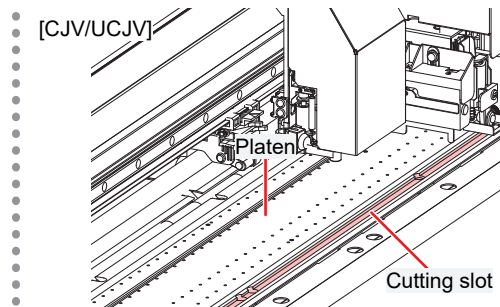
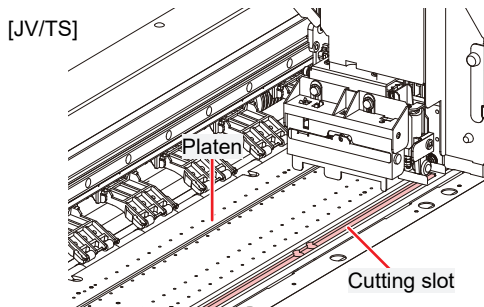

Pinch Rollers and Grit Rollers

The pinch rollers and grit rollers are used to grip and feed the media.

[JV/TS]

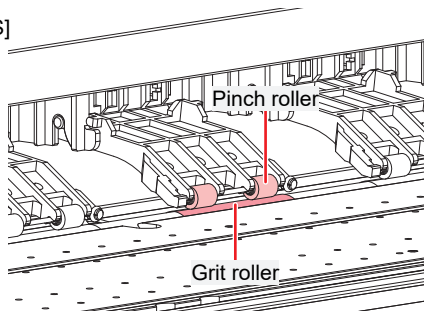

[CJV/UCJV]

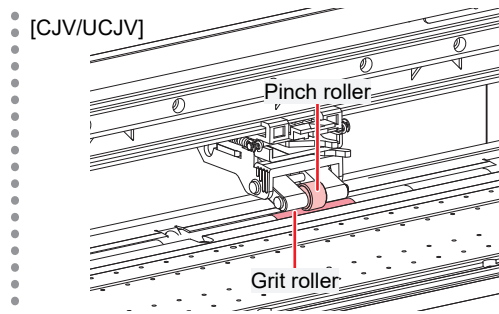

When the machine is not in use, raise the clamp lever to separate the pinch rollers from the grit rollers.

- Leaving the pinch rollers lowered may cause them to become deformed and prevent media from being fed correctly.
- Leaving media loaded will subject it to force from the pinch rollers, which may leave pinch roller marks on it.



JV/TS

- Attach the clamp changeover sliders to the pinch rollers at the left and right-hand ends of the media. The pinch rollers can be raised by attaching clamp changeover sliders. This prevents gripping the left and right-hand ends of the media for consistent feeding.

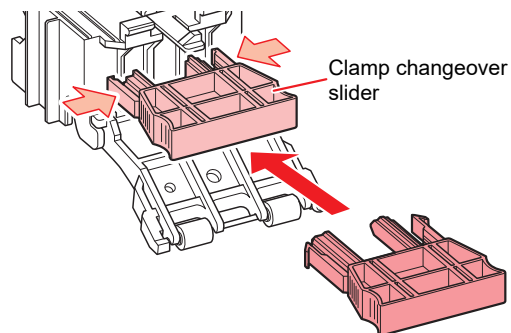

Media Sensor

The media sensor detects the presence/absence of media. The sensor must be covered by the media to detect the media width.

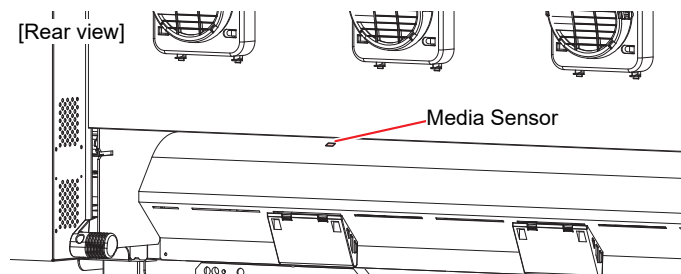

Power Supply Switch

● Main power switch

This is located at the rear on the right-hand side of the product.

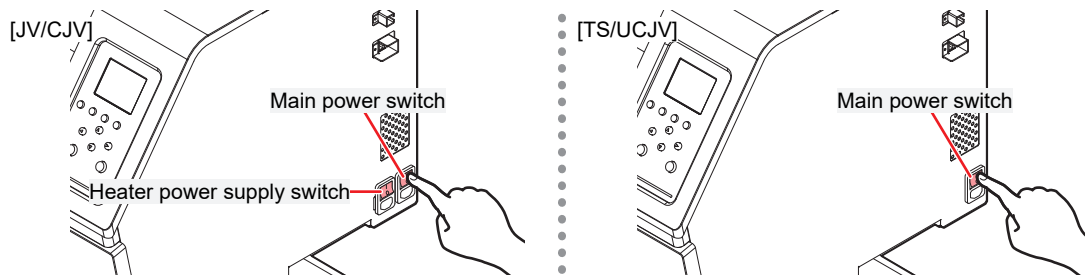

- Do not turn off the main power supply. Turning off the main power supply will disable the automatic maintenance function (including nozzle clogging prevention function and ink discharge channel cleaning function). This increases the risk of ejection failures (such as nozzle clogging or deflection).

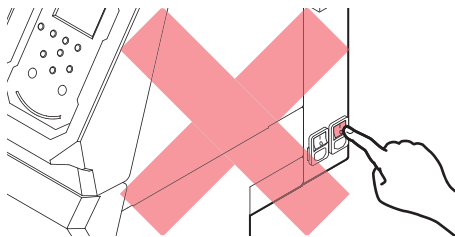

● [END/POWER] key

The [END/POWER] key is the key normally used to turn the power on and off.

To turn off the power, hold down the [END/POWER] key. Press the [ENTER] key once the instructions appear on the display.

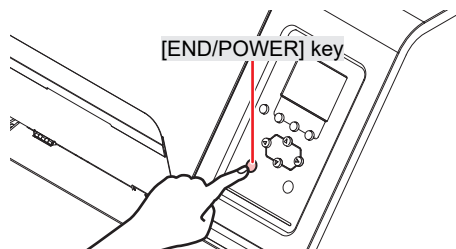

Operating Panel

This is used to control the product and make/change settings.

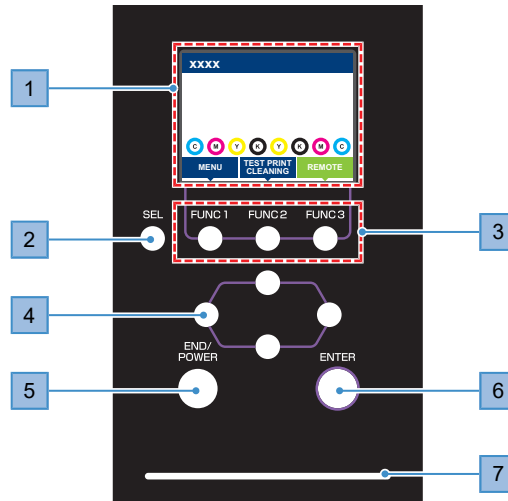

No.	Name	Overview																						
1	Display	"Display"(P. 34)																						
2	[SEL] key	Selects the function for the corresponding [FUNCTION] key.																						
3	[FUNCTION] key	Used for test printing, head cleaning, and editing settings "[FUNCTION] key"(P. 36)																						
4	[JOG] key 	Used to move the carriage, feed media, and select settings																						
5	[END/POWER] key	Used to cancel the last setting entered, return to the previous level of the setting menu, or to turn power on and off <ul style="list-style-type: none"> • Illuminates in blue when the power is on. "Turning On the Power"(P. 37) • To turn off the power, hold down the key. "Turning Off the Power"(P. 38) 																						
6	[ENTER] key	Used to move to the next level menu and to confirm settings. This can also be used to display product information. "Displaying Machine Information (Local Guidance)"(P. 36)																						
7	Status lamp	This lamp indicates the machine status. <table border="1"> <tbody> <tr> <td></td> <td>Off</td> <td>Indicates LOCAL mode. Used for test printing, maintenance, and settings</td> </tr> <tr> <td rowspan="2">Light blue</td> <td>Illuminated</td> <td>Indicates REMOTE mode. The product is in standby to receive print data.</td> </tr> <tr> <td>Flashing</td> <td>Indicates that printing is in progress. This also flashes to indicate test printing—for example, when printing built-in patterns.</td> </tr> <tr> <td>Blue</td> <td>Illuminated</td> <td>Indicates that data remains to be printed. Switch to REMOTE mode and start printing</td> </tr> <tr> <td>Green</td> <td>Flashing</td> <td>Indicates that automatic maintenance is underway. Some functions will be limited until maintenance has ended.</td> </tr> <tr> <td>Yellow</td> <td>Flashing</td> <td>Ink Near End status (very little ink remains). "When Ink Near End is Displayed"(P. 45)</td> </tr> <tr> <td rowspan="2">Red</td> <td>Flashing</td> <td>An error has occurred. Refer to the error code list and take appropriate action. "Error Message"(P. 267)</td> </tr> <tr> <td>Illuminated</td> <td>A system error (SYSTEM HALT) has occurred. Contact our service office. "SYSTEM HALT"(P. 278)</td> </tr> </tbody> </table>		Off	Indicates LOCAL mode. Used for test printing, maintenance, and settings	Light blue	Illuminated	Indicates REMOTE mode. The product is in standby to receive print data.	Flashing	Indicates that printing is in progress. This also flashes to indicate test printing—for example, when printing built-in patterns.	Blue	Illuminated	Indicates that data remains to be printed. Switch to REMOTE mode and start printing	Green	Flashing	Indicates that automatic maintenance is underway. Some functions will be limited until maintenance has ended.	Yellow	Flashing	Ink Near End status (very little ink remains). "When Ink Near End is Displayed"(P. 45)	Red	Flashing	An error has occurred. Refer to the error code list and take appropriate action. "Error Message"(P. 267)	Illuminated	A system error (SYSTEM HALT) has occurred. Contact our service office. "SYSTEM HALT"(P. 278)
	Off	Indicates LOCAL mode. Used for test printing, maintenance, and settings																						
Light blue	Illuminated	Indicates REMOTE mode. The product is in standby to receive print data.																						
	Flashing	Indicates that printing is in progress. This also flashes to indicate test printing—for example, when printing built-in patterns.																						
Blue	Illuminated	Indicates that data remains to be printed. Switch to REMOTE mode and start printing																						
Green	Flashing	Indicates that automatic maintenance is underway. Some functions will be limited until maintenance has ended.																						
Yellow	Flashing	Ink Near End status (very little ink remains). "When Ink Near End is Displayed"(P. 45)																						
Red	Flashing	An error has occurred. Refer to the error code list and take appropriate action. "Error Message"(P. 267)																						
	Illuminated	A system error (SYSTEM HALT) has occurred. Contact our service office. "SYSTEM HALT"(P. 278)																						

Display

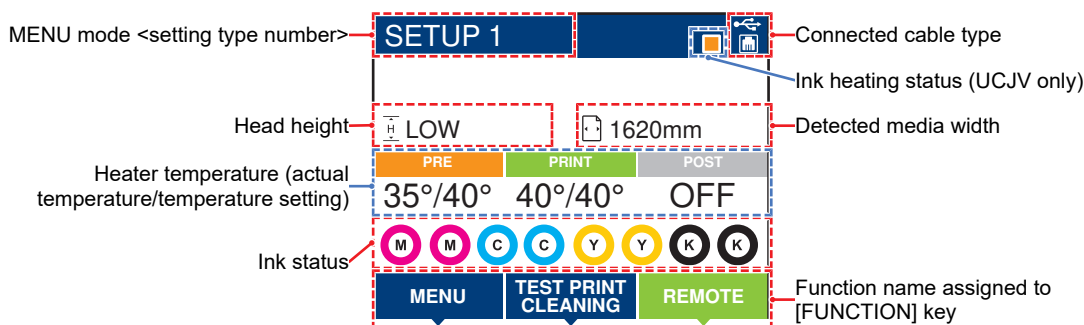

● Heater temperature

The heater status is indicated by different colors.

- Orange: Adjusting to temperature setting.
- Green: At temperature setting.
- Gray: Heater is turned off.



- TS: Only equipped with a post-heater. (The print heater is optional ["Options"\(P. 286\).](#))
- UCJV: Only equipped with a pre-heater. (The print heater and post-heater can be installed as options ["Options"\(P. 286\).](#))

● Ink heating status (UCJV only)

The ink heating status and errors are indicated by different colors.

- Orange: Adjusting to temperature setting. Ink heating starts automatically before printing.
- Light blue: Temperature being maintained stable after reaching temperature setting.
- Green: Ink temperature is stable. Printing can be started immediately.
- Gray: Ink heating is turned off.
- Red: An ink heating related error has occurred.

MENU mode



Four menu modes are available.

Name	Overview
LOCAL mode	Used for test printing, maintenance, and settings
REMOTE mode	Prints the print data received from a PC.
MENU mode	Press the [MENU] on the LOCAL mode screen to switch to MENU mode. This is used to set various functions.
NOT-READY mode	Status before media is detected

Ink status



















Ink pack status such as remaining ink levels and ink errors are indicated by icons.

Icon	Overview
	Displays remaining ink levels using a 9-stage icon.

Icon	Overview							
	Full	1/8 used	1/4 used	3/8 used	1/2 used	5/8 used	3/4 used	7/8 used
	Very little ink remains. Prepare fresh ink.							
	Printing is not possible. Displayed when ink is depleted or an ink error has occurred.  "Ink error" (P. 266)							

[FUNCTION] key

This section describes the functions and roles assigned to the [FUNCTION] key.

Icon	Overview
	Displays the various menu screens.  "Setup"(P. 173)
	Displays maintenance functions such as test printing and cleaning.
	Switches from LOCAL mode to REMOTE mode.
	Displays adjustment functions such as feed adjustment and drop position adjustment.
	Displays the Heater Temperature Setup screen.
	Clears received data.
	Used to switch from REMOTE mode to LOCAL mode
	Used to cut media
	Used to move to the previous menu screen
	Used to move to the next menu screen
	Used to close the confirmation screen in response to prompts or other messages
	Used to disable functions
	Indicates that the function is assigned. Displays settings and functions.
	Used to enable or disable multiple items
	Displays the cutting condition input screen.
	Displays the test cutting and other cutting related function screens.
	Displays the pinch roller setting screen.

Displaying Machine Information (Local Guidance)

Press the [ENTER] key on the LOCAL mode screen to display the following information.

- Ink information: Displays ink type, remaining ink levels, and ink errors.
- Information: Displays information such as media width, head height, product serial number, firmware version, command version, and LAN connection status.
- Nozzle check: Displays the number of nozzles detected as clogged in the nozzle check.

1.2 Connecting the Power Cable

- 1 Check to confirm that the main power supply is turned off.
- 2 Connect the cable band to the machine.
- 3 Connect the power cable to the inlet of the machine.
- 4 Secure the power cable to the cable band.
 - Pass the power cable through the clamp and clamp until it clicks into place.

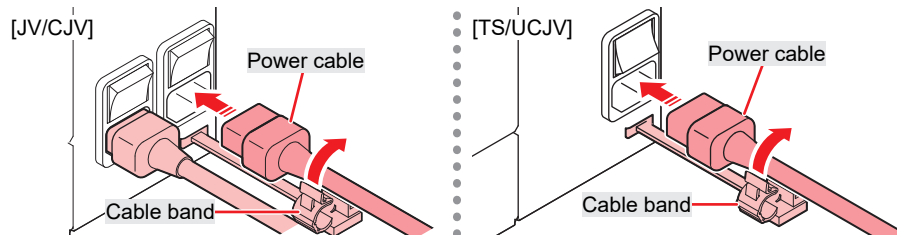

- 5 Plug the power plug into the power outlet.

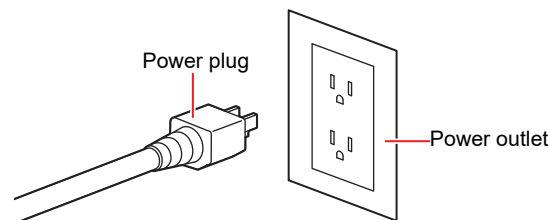

- Do not handle the power plug with wet hands. Disregarding this precaution may result in electric shock.

Turning On the Power

- 1 Check to confirm that the main power supply is turned on.
 - If the main power supply switch is not turned on, set to "I".

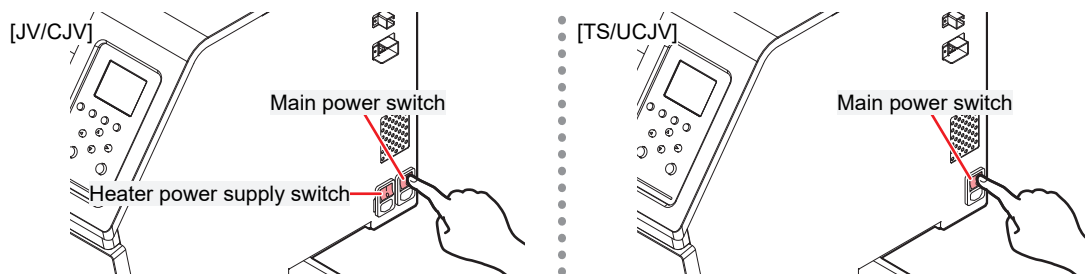

2 Press the [END/POWER] key to turn on power.

- The firmware version appears on the display, and the initial operation is executed. The machine will then enter the Media Select mode, and is ready for use.

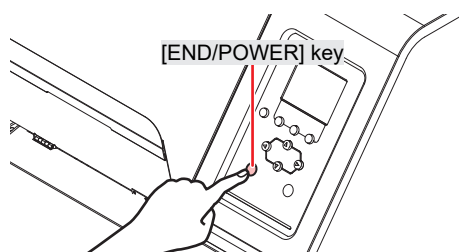

- If sudden temperature fluctuations (of ± 10 °C or more) are detected while the power is turned off, maintenance will be performed automatically when the machine is restarted. If a warning message appears when the machine is restarted, perform a test print to check the nozzle state.

3 Turn on the power for the connected PC.



- Close the front cover and maintenance covers. Leaving any of the covers open will disable the automatic maintenance function (including nozzle clogging prevention function and waste ink draining channel cleaning function). This will increase the risk of failure or ejection failures (e.g., nozzle clogging or deflection).

Turning Off the Power



- Check the following when turning off power:
 - (1) The front cover and maintenance covers are closed.
 - Leaving any of the covers open will disable the automatic maintenance function (including nozzle clogging prevention function and waste ink draining channel cleaning function).
 - (2) The carriage has returned to the capping station.
 - If not, the print head nozzle may dry out, resulting in ejection failures (such as nozzle clogging or deflection).
 - (3) Data is not being received
 - (4) No errors have occurred.
 -  ["Problems Causing Messages to Appear"\(P. 264\)](#)

1 Turn off the power to the PC connected.

2 Hold down the [END/ POWER] key.

- A power off confirmation screen appears. Press the [ENTER] key to turn the power off.

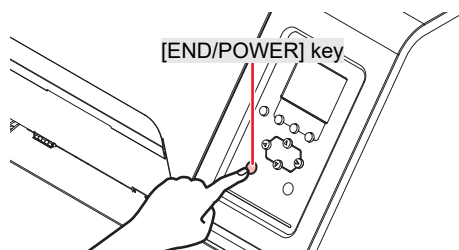



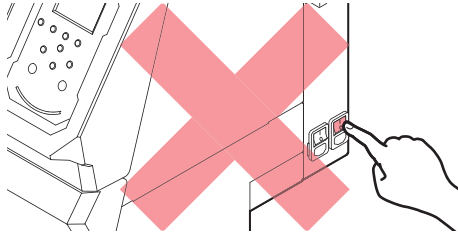

- Do not turn off the main power supply. Turning off the main power supply will disable the automatic maintenance function (including nozzle clogging prevention function and ink discharge channel cleaning function). This increases the risk of ejection failures (such as nozzle clogging or deflection).



1.3 Connecting a PC to the Product

Connect the machine to the RIP PC. The following cables can be used:

1.  "Using a LAN Cable"(P. 40) **(Recommended)**
2.  "Using a USB Cable"(P. 41)

Important! **When using the USB cable**

- Data may be transferred to the machine too slowly, **causing the carriage to pause at the left-hand or right-hand end** during printing.

Using a LAN Cable

Connect a PC to this product using a LAN cable. Insert a LAN cable until it engages with a click.



- Do not unplug the cable while data is being transferred.

● Network Connection Precautions

Make sure the network is set up as follows: Printing is not possible if the network is not set up correctly.

- Use a Category 6 or higher LAN cable.
- The PC used to transfer print data must be located on the same network as this product. This product cannot be connected via a router.
- Use a 1000BASE-T compatible computer or switching hub. Printing requires 1000BASE-T support.

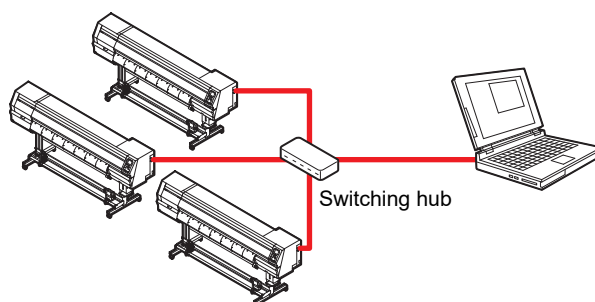

● Checking the LAN connection

1 Check the display on this product.

- Local guidance can be used for checking.  "[Displaying Machine Information \(Local Guidance\)](#)"(P. 36) Printing is not possible if "100Mbps", "10Mbps", or "No Connect" is displayed.

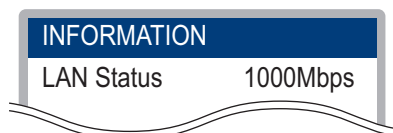

2 Check the lamp on the LAN connector.

- The LAN connector lamp illuminates when the machine is running.

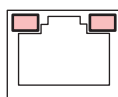

Color	Status	Overview
Green	Illuminated	Connected via 1000BASE-T
	Off	Connected via a network other than 1000BASE-T <ul style="list-style-type: none"> 1,000 Mbps is not supported if only the orange lamp is illuminated or flashing. Check the specifications for the PC, peripheral devices, and cable.
Orange	Illuminated	Linked up (connected).
	Flashing	Data being received
	Off	Link down (not connected)

Using a USB Cable

Connect a PC to this product using a USB interface cable.



- Do not unplug the cable while data is being transferred.



- Use RIP software that supports the USB interface.



- If the PC does not have a USB port, contact your local distributor, our sales office, or service center.



When using the USB cable

- Data may be transferred to the machine too slowly, **causing the carriage to pause at the left-hand or right-hand end** during printing.

● USB Connection Precautions

- When connecting more than one 330 Series to a PC
 - If the PC has more than one USB port, try connecting to a different USB port to check whether the product is correctly recognized. If the product is still unrecognized even when connected to a different USB port, use a commercially-available USB active repeater cable.
- When extending the USB cable
 - Use a commercially-available USB active repeater cable. However, make sure that the combined length of the USB cable and the USB active repeater cable does not exceed 20 m.
 - If the USB cable is extended, this may reduce the data transfer speed to the machine, causing the carriage to pause at the left-hand or right-hand end during printing.
- USB high-speed mode peripheral devices
 - It may not be possible to recognize USB peripheral devices if USB high-speed mode peripheral devices (e.g., USB memory, USB HDD devices) are connected to the PC to which the product is connected. If external USB hard disk drives or other similar devices are connected, this may reduce the data transfer speed to the machine, causing the carriage to pause at the left-hand or right-hand end during printing.
- Unplugging USB memory devices
 - When unplugging USB memory devices from the PC to which this product is connected, use "Stop" in "Safely removing hardware" before unplugging. Otherwise, an [ERROR 201 Command Error] will occur.

1.4 System Configuration

Use RIP software to request to print data created using applications like Illustrator or Photoshop.

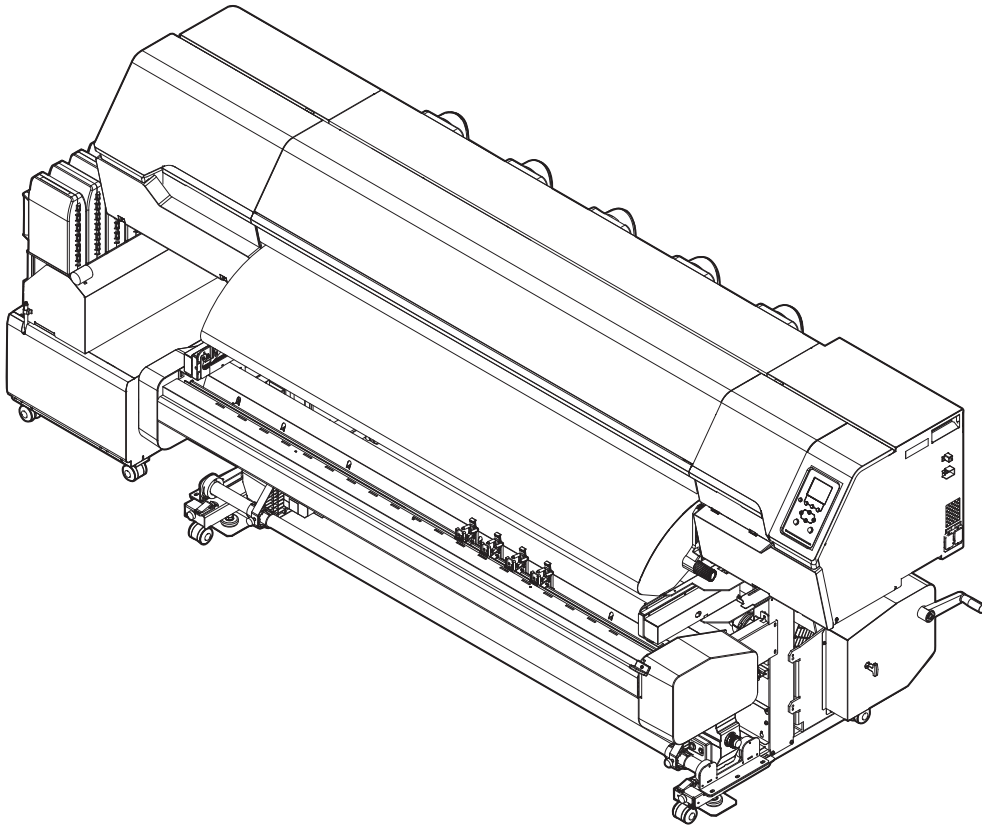
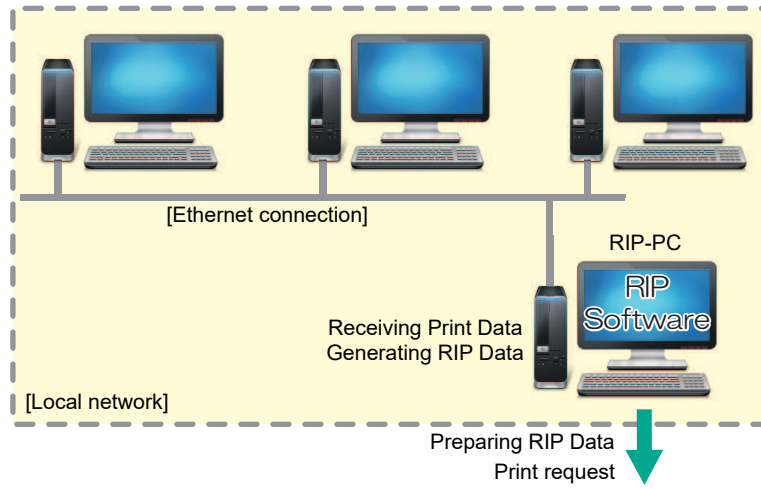

Installing the Mimaki Driver

1 Download the Mimaki driver from our website.

- <https://mimaki.com/download/inkjet.html>
[330 Series] > [Driver/Utility]

2 Install the MIMAKI driver.

Installing RIP Software

The explanation here applies to MIMAKI RIP software (RasterLink).

- Important!** • If using TxLink, refer to the TxLink operating manual.

1 Install RasterLink.

- The following icon appears on the PC desktop once the software has been installed.



- For more information, refer to the RasterLink installation guide. <https://mimaki.com/download/software.html>



- Once installed, activate the license for Rasterlink. Otherwise, "Profile Update" will not start.

Obtaining Color Profiles

Print quality (e.g., tone, bleeding) will vary depending on the media and ink set. To maintain consistent print quality, select a color profile that suits the media and ink set.

- The RasterLink Series includes a function allowing color profiles to be downloaded and installed directly from the Internet. For more information, refer to "Installing Profiles" in the RasterLink Series installation guide.
<https://mimaki.com/download/software.html>
[RasterLink Series used] > [Manuals]
- Color profiles for Mimaki RIP software (RasterLink/TxLink) are available on the Mimaki website.
<https://mimaki.com/download/inkjet.html>
[330 Series] > [Profile]

Setting Up RIP Software

The explanation here applies to MIMAKI RIP software (RasterLink).

- Important!** • If using TxLink, refer to the TxLink operating manual.

1 Launch RasterLink.

- The [Printer Management] screen appears.
- To add a new model, launch RasterLink, then select [Environment] > [Printer Management].

2 Register 330 Series.

(1) Click [Add].

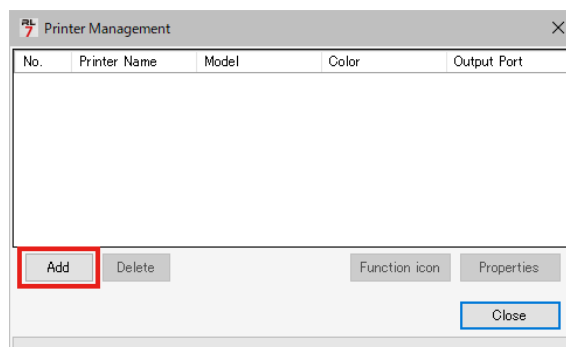

(2) Set the specifics for 330 Series.

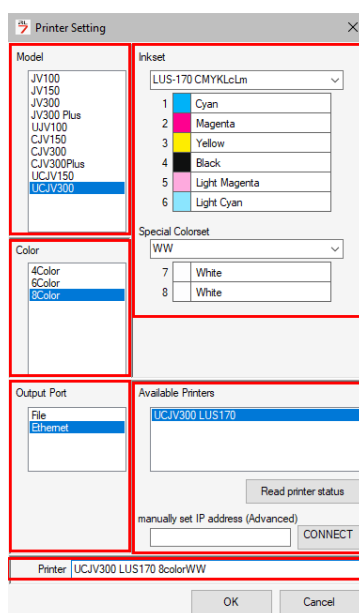

- Model: Select the model.
 - Color: Select the ink set filled.
 - Output Port: Select the cable connected.
 - Available Printers: Select 330 Series connected.
 - Printer: Enter a name as required.
- (3) Click [OK].
- A confirmation screen appears.
- (4) Click [Yes].
- Printer registration starts.



- For more information, refer to the RasterLink installation guide. <https://mimaki.com/download/software.html>

1.5 Ink Replacement Method

When Ink Near End is Displayed

Ink levels are low. We recommend replacing with new ink as soon as possible, because the ink packs are nearly empty. Printing is still possible but continuous printing is not, and some maintenance functions such as cleaning are disabled. Note that ink may run out during printing.

To check which color ink needs to be replaced, press the [ENTER] key on the LOCAL mode screen.  ["Displaying Machine Information \(Local Guidance\)"\(P. 36\)](#)

When Ink End is Displayed

The ink has run out. Replace with new ink.

Thoroughly read the following and make sure you understand its contents.

 ["Notes on Handling Ink or any Other Liquid Used with the Machine"\(P. 15\)](#)



- Pay close attention to ventilation and be sure to wear safety glasses, gloves, and a mask when handling ink, maintenance liquid, waste ink, or other solutions used with the machine. Leaking ink may adhere to the skin or get into the eyes or mouth.

Replacing Ink

JV/CJV/TS

JV

CJV

TS



- The ink pack is filled with slightly more ink than the indicated value. A small amount of ink remains when the indicated amount of ink has been consumed and Ink End is displayed. The ink in the ink pack cannot be used up completely.

● Removing Ink Eco-cases

- 1 Push down the lever on the pedestal, and remove the ink Eco-case.

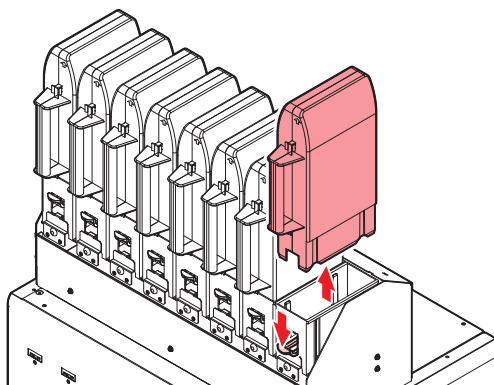

- 2 Open the ink eco-case, then remove the ink pack.

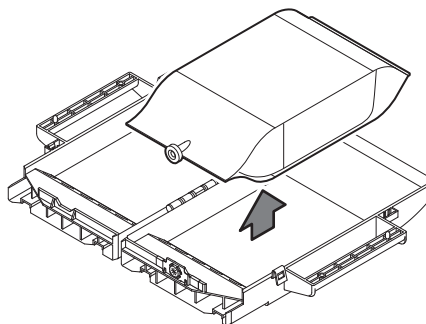

- 3 Remove the ink IC chip.

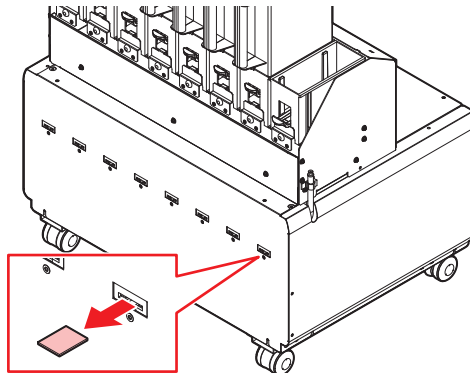

4 Wipe off any ink adhering to the ink eco-case opening.

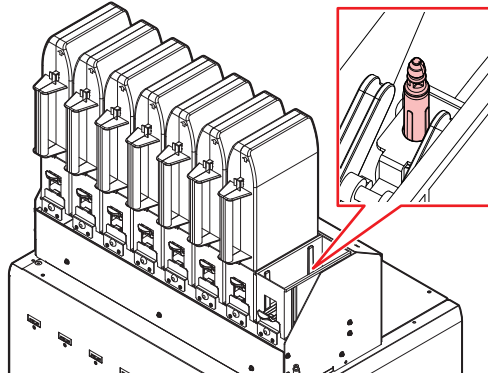

- Check to confirm no foreign matter such as dust or paper towel matter is adhered to the opening. If foreign matter is present, this may block the ink path and lead to leakage.



- We recommend replacing the ink absorber each time you replace the ink pack, to prevent dirt building up on the pedestal of the ink supply unit.

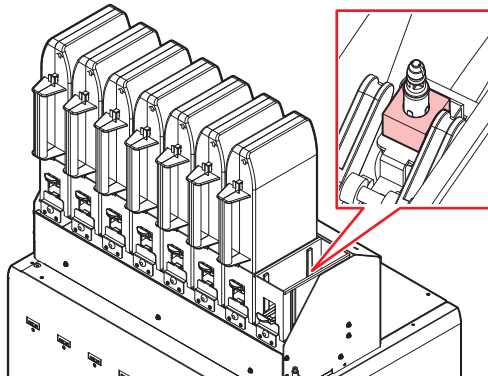

- When disposing of ink, maintenance liquid or other liquid used with the product, or containers or non-woven fabric contaminated with ink or other liquid, contact an industrial waste disposal operator or dispose of the product in accordance with the local laws and regulations.

● Preparing the Ink

1 Pull out the ink pack and ink IC chip from the ink package.

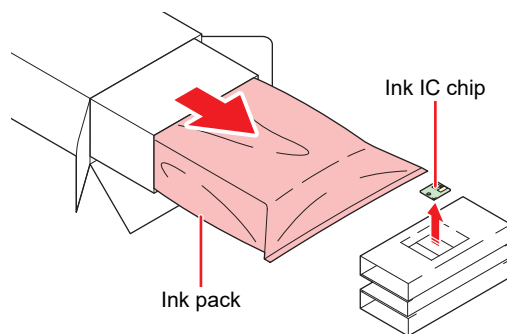

2 Shake the ink eco-case slowly from left to right at least 20 times.

- Shake the bottle slowly from left to right to ensure that the ink moves inside, holding the ink pack opening with a paper towel.

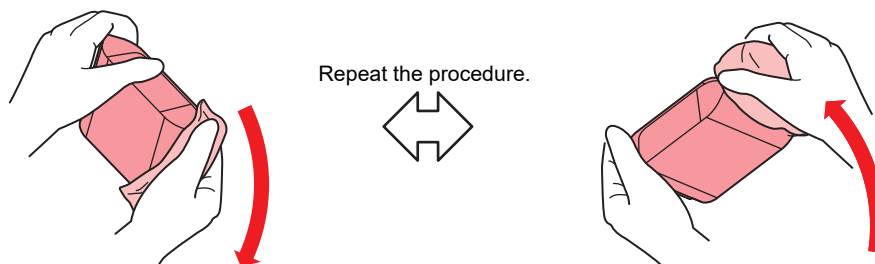

- When using an ink pack with ink remaining, hold a paper towel over the ink eco-case opening and shake slowly with the ink eco-case tilted upright.

3 Remove the seal attached to the ink pack opening.



- Remove the seal completely. If any parts of the seal remain, ink may leak when the ink eco-case is removed from the base.



4 Place the ink pack inside the ink eco-case.

- Push the ink pack connector into the ink eco-case slot. Ink may not be supplied if the connector is out of position.
- Position the pack as indicated on the label on the ink eco-case.

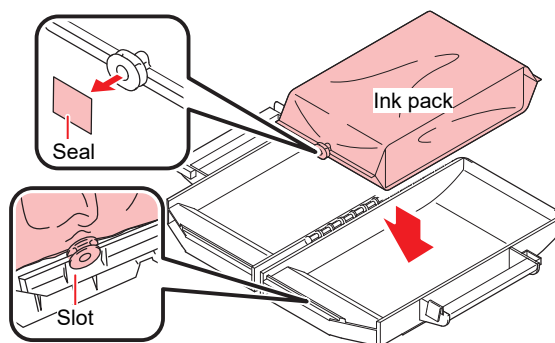

5 Close the ink eco-case gently to avoid pinching the ink pack.



- Be careful to avoid catching your hands or fingers.

● Mounting the ink

The order of the ink eco-cases to be set varies depending on the ink set you are currently using. Check the ink slot numbers, then insert the correct color ink eco-cases.

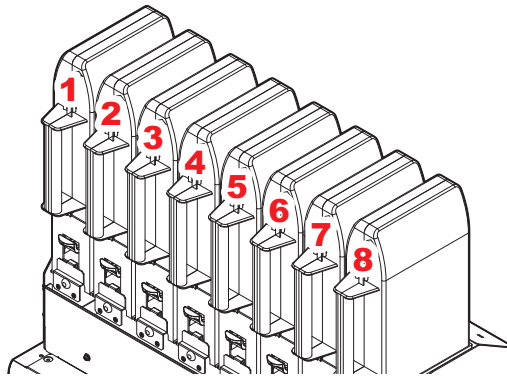

Ink set		Ink bottle positions (specified by color)							
		1	2	3	4	5	6	7	8
JV/CJV	4-color	M	M	C	C	Y	Y	K	K
	6-color, W	M	Lm	C	Lc	Y	W	K	W
	8-color	M	Lm	C	Lc	Y	Or	K	Lk
TS	4-color	M	M	BL	BL	Y	Y	K	K
	6-color	M	Lm	BL	Lbl	Y	Y	K	K
	7-color	M	Lm	BL	Lbl	Y	Y	K	Lk
	4-color, FY, FP	M	M	BL	BL	Y	FY	K	FP
	6-color, FY, FP	M	Lm	BL	Lbl	Y	FY	K	FP
	8-color	M	R	C	BL	Lk	GR	K	Y

1 Set an eco-case on the base.

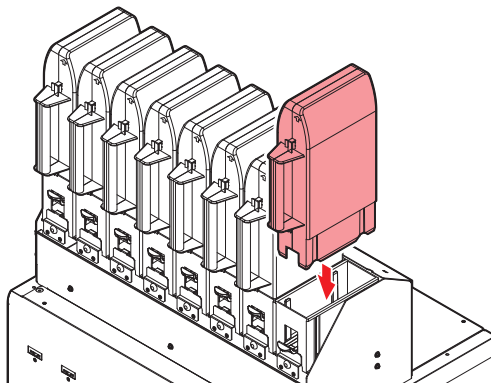

- Fully push in the eco-case. Otherwise, ink may not be fed properly.

2 Insert the new ink IC chip into the ink IC chip slot.

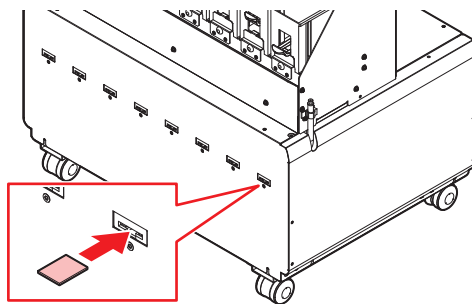

- Insert the ink IC chip with the metal side facing up. Inserting it in the wrong way may cause failure of the machine or damage the ink IC chip.



- Do not touch the metal parts of the ink IC chip. Static electricity may damage the ink IC chip, and dirt or damage may cause the ink IC chip read error.

- **Ink IC chips**: The marking on the ink IC chip indicates the color information.

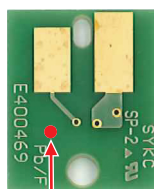

Marking locatio

Ink Color	Marking
Cyan	● (One blue circle)
Magenta	● (One red circle)
Yellow	● (One yellow circle)
Black	● (One black circle)
Light cyan	●● (Two blue circles)
Light magenta	●● (Two red circles)
Light black	●● (Two black circles)
Orange	● (One orange circle)
White	○ (One white circle)
Blue	●● (One blue circle/one red circle)
Light blue	●●● (Two blue circles/one red circle)
Fluorescent pink	●● (Two orange circles)
Fluorescent yellow	●● (Two yellow circles)
Red	●● (One red circle/one yellow circle)
Green	● (One green circle)



- Insert the ink IC chip included in the package with the ink. The ink IC chip stores information such as the ink color, remaining amount, and expiration date. Printing is not possible if an incorrect ink IC chip is inserted.

UCJV

UCJV

● Ink caps

The type of ink cap that can be used will differ depending on the ink type. Note that only the following combinations can be used.

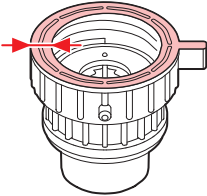
Ink type	Cap type
<ul style="list-style-type: none"> • LUS-170/175 ink • LUS-200 ink • LUS-190/210 ink 	<p>[Cap B]</p> 

● Replacing Ink

- 1 Rotate the lever on the tank section from left to right.

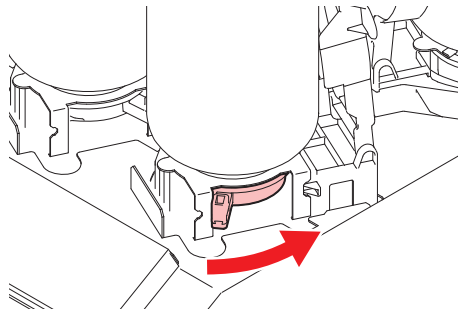

- Never attempt to rotate the ink bottles. Doing so may result in leaking ink.

- 2 Lift the ink bottles vertically.

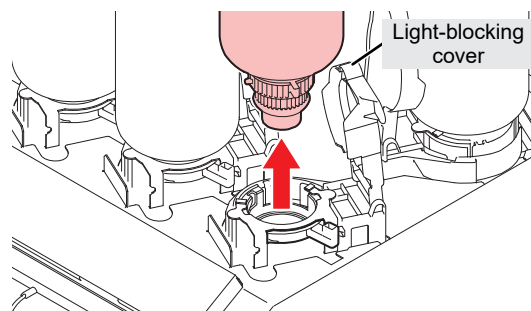

- Check to confirm that the light-blocking cover is closed when removing ink bottles. Close the light-blocking cover by hand if it is open. If the light-blocking cover is left open, the ink may harden, resulting in printer failure.
- Be careful to prevent ink leaks from the ink bottles.

Important!

- The O-rings fitted to the bottle caps may become detached when removing ink bottles. Refit the O-ring if it becomes detached.

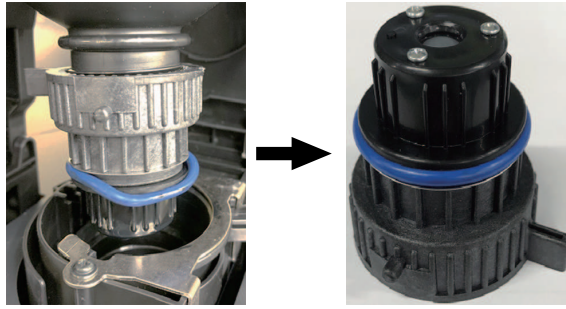

3 Soak up any ink droplets on the ink bottle caps.

- Use an ink wipe pad to absorb the ink sufficiently so that it does not drip.

no image

4 Wipe off any ink on the ink bottle caps with paper wipes.



- Check to confirm that there is no foreign matter, such as non-woven fabric scraps or dust, adhering to the ink bottle caps. Continuing to use it when it is dirty may result in foreign matter blocking the ink channels, causing ink leakage.

5 Remove the bottle caps from the ink bottles.

- If the ink bottle caps are tight, remove using a tightening tool.

6 Remove the ink IC chip.

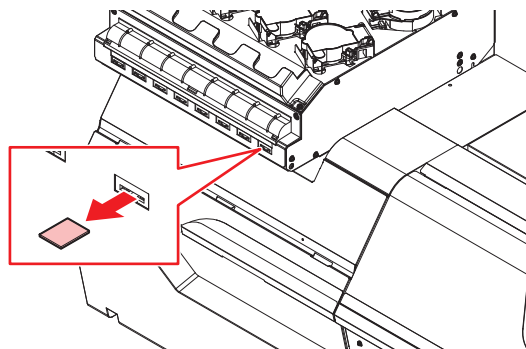

● Preparing the Ink

1 Shake the ink bottle to the left and right slowly at least 20 times.

- Tighten the ink bottle lid securely, then shake the bottle slowly from left to right to ensure that the ink moves inside, holding the ink bottle lid with a piece of recommended non-woven fabric.

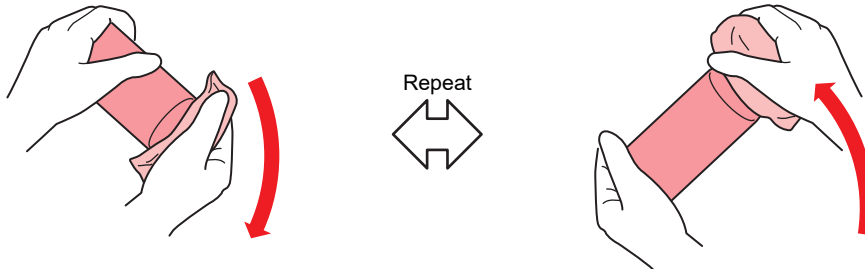

- Shake slowly. If the bottle is shaken too violently, ink may leak out or the air mixed in the ink may cause nozzle clogging.
- If the ink bottle is partially used, tilt it slowly until the ink bottle is upright.

2 Remove the ink bottle lid.

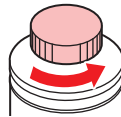

Important! If the mouth of the ink bottle is fitted with a seal

- Cut the seal open using a craft knife. There is a risk of ink leakage if parts of the seal remain.

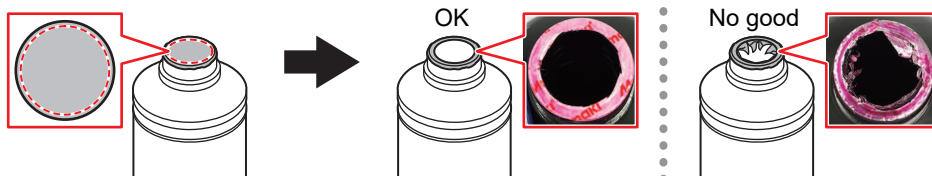

- Take care not to damage the mouth of the ink bottle. There is a risk of ink leakage if the mouth is damaged.
- Be careful not to drop any of the seal fragments into the ink bottle. If the ink bottle is used with seal fragments inside, these may clog the bottle cap, preventing ink from being supplied.

3 Attach the bottle cap to the ink bottle.

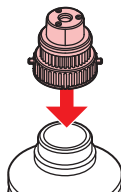



- Wipe off any ink or maintenance liquid remaining on the ink bottle or the bottle cap. Otherwise there is a risk of ink leakage due to loosening of the ink bottle cap.

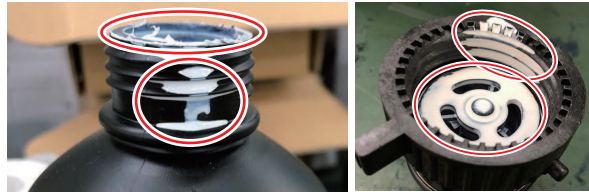

- Check to confirm that there is no foreign matter, such as paper towel scraps or dust, adhering to the ink bottle caps. If foreign matter is present, this may block the ink path and lead to leakage.

4 Use the tightening jig to tighten the ink bottle caps in place.

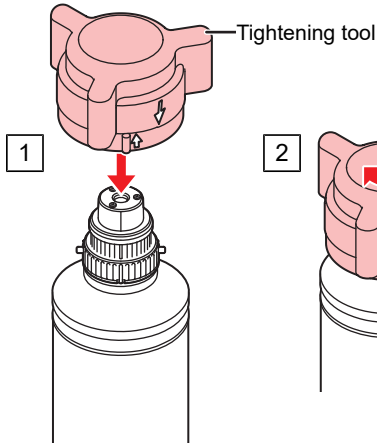

[SPA-0232]



Position the upper arrow within this range!

Good example



Bad example



[SPA-0328]



Position the upper arrow within this range!

Good example

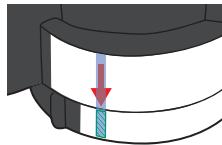

Bad example

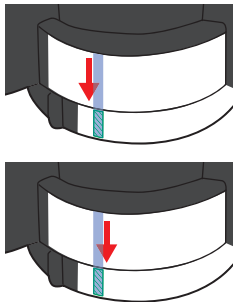

- Do not overtighten the ink bottle caps. Disregarding this precaution may result in damage, idling or ink leakage. If the arrow goes beyond the range indicated above, loosen the bottle cap, and repeat the steps again.
- Do not leave ink bottles with the ink bottle caps fitted for extended periods. Disregarding this precaution may result in the ink hardening.

5 Turn the ink bottle upside-down to check that no ink leaks occur.

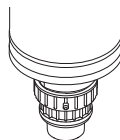

● Mounting the ink

The order of ink bottles to be set depends on the ink set you are currently using. Check the ink slot numbers and insert the correct color ink bottles.

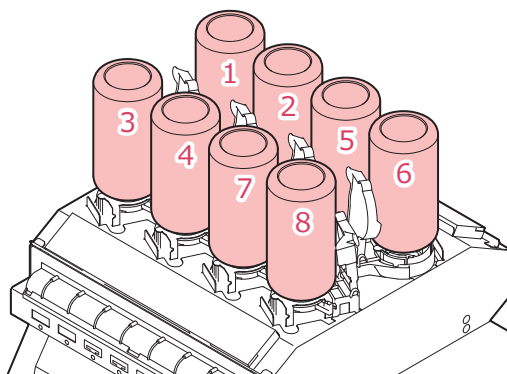

UCJV		Ink bottle positions (specified by color)							
Ink Type	Ink set	1	2	3	4	5	6	7	8
LUS-170/175, 200	4-color	M	C	Y	K	K	Y	C	M
LUS-170/175	4-color, W, Cl	M	C	Y	K	Cl	Cl	W	W
	6-color, W	M	C	Y	K	Lc	Lm	W	W
LUS-200	4-color, W	M	C	Y	K	C	M	W	W
LUS-190/210	4-color	M	M	C	C	Y	Y	K	K
	4-color, W	M	M	C	C	Y	K	W	W

1 Insert the new ink IC chip into the ink IC chip slot.

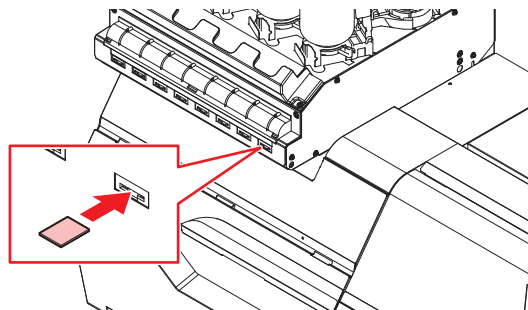

- Insert the ink IC chip with the metal side facing up. Inserting it in the wrong way may cause failure of the machine or damage the ink IC chip.



- Do not touch the metal parts of the ink IC chip. Static electricity may damage the ink IC chip, and dirt or damage may cause the ink IC chip read error.

2 Mount the ink bottles.

- Rotate the lever from the left to the right end, then mount the ink bottle.

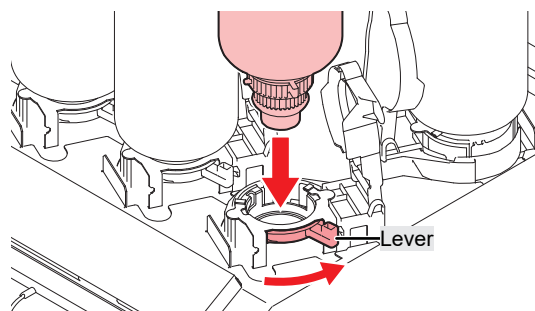



- You may apply the maintenance liquid onto the O-ring of the ink bottle caps so that the ink bottle can be inserted easily. Use the appropriate maintenance liquid to suit the ink being used.



3 Rotate the lever from right to left to secure the bottle in place.



- Never attempt to rotate the ink bottles. Doing so may result in leaking ink.



- Once the ink bottle is mounted, use up the ink as quickly as possible.

- Ink IC chips:** The marking on the ink IC chip indicates the color information.

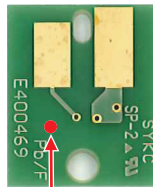

Marking locatio

Ink Color	Marking
Cyan	● (One blue circle)
Magenta	● (One red circle)
Yellow	● (One yellow circle)
Black	● (One black circle)
Light cyan	●● (Two blue circles)
Light magenta	●● (Two red circles)
White	○ (One white circle)
Clear ink	○○ (Two white circles)



- Insert the ink IC chip included in the package with the ink. The ink IC chip stores information such as the ink color, remaining amount, and expiration date. Printing is not possible if an incorrect ink IC chip is inserted.

Chapter 2 Printing



This chapter

This chapter describes printing procedures and settings.

Print Process	58	Test Printing	90
Adjusting Print Head Height	61	Changing the Layout Direction for Test Printing.....	90
Adjust the Pinch Roller Positions.	63	Checking White Ink Ejection	91
1,600 mm Size	64	Ejection Failures	91
1,300 mm Size	65	Head Cleaning.....	92
Loading the Media	66	Feed Correction.....	93
Media	66	Feed Correction Procedure.....	93
Take-up unit	67	Correcting the Drop Position	95
Feeding unit	72	Drop Position Correction Procedure	95
Media Changer.....	74	Preparing RIP data	97
Loading the Roll Media	76	Printing	99
Setting Leaf Media	81	Changing the Origin	99
Registering the Media	85	Starting Printing	100
Setting the Pressure and Number of Pinch Rollers to Use	87	Stopping Printing (Data Clear)	101
Setting the Heater Temperature	89	Cutting the media	102
		V-shaped Cutting	103

2.1 Print Process

1. Turn on the power.

["Turning On the Power"\(P. 37\)](#)

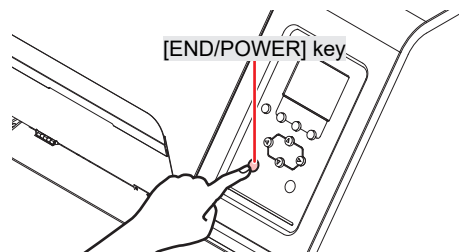

2. Connect a RIP PC to the machine.

["Using a USB Cable"\(P. 41\)](#)

["Using a LAN Cable"\(P. 40\)](#)

3. Setting Up RIP Software

["Installing RIP Software"\(P. 43\)](#) (required first time only)

["Obtaining Color Profiles"\(P. 43\)](#)

["Setting Up RIP Software"\(P. 43\)](#) (required first time only)

4. Adjusting Print Head Height

Adjust the height adjustment lever to suit the media. ["Adjusting Print Head Height"\(P. 61\)](#)

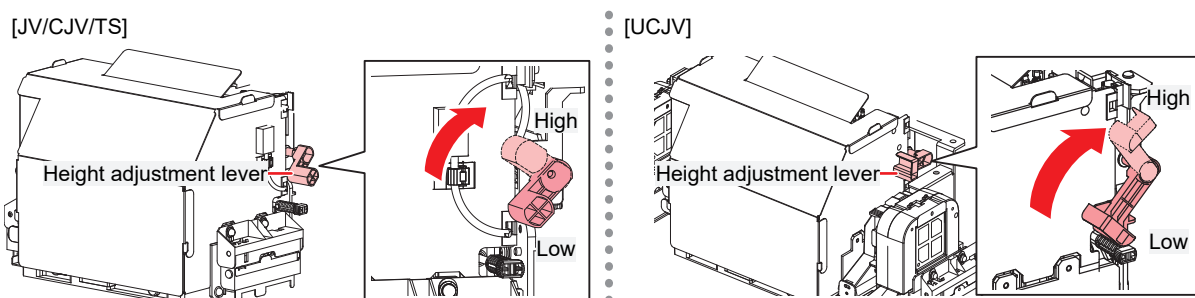

5. Adjust the Pinch Roller Positions.

Adjust the pinch roller positions to suit the width of the set media. Adjust the pinch roller positions so that the pinch rollers are positioned above the grit rollers. The pinch rollers at both ends should be aligned to within 10 cm from the left edges and 2 cm from the right edges of the media. ["Adjust the Pinch Roller Positions."\(P. 63\)](#)



- The description here applies to the CJV/UCJV.

6. Loading the Media

This machine can be used with roll media and leaf media.  ["Loading the Media"\(P. 66\)](#)

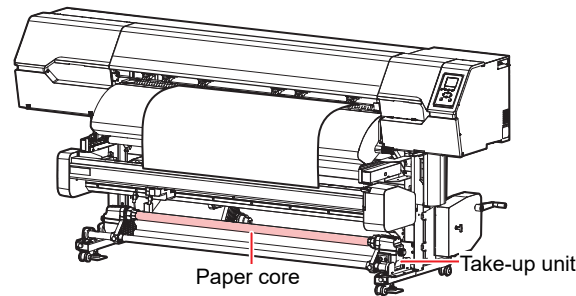

7. Adjust the number and pressure of pinch rollers to use.

Set an appropriate pressure for the set media.  ["Setting the Pressure and Number of Pinch Rollers to Use"\(P. 87\)](#)



- The description here applies to the CJV/UCJV.

8. Setting the Heater Temperature

 ["Setting the Heater Temperature"\(P. 89\)](#)

9. Check the state of the print head nozzles.

 ["Test Printing"\(P. 90\)](#)

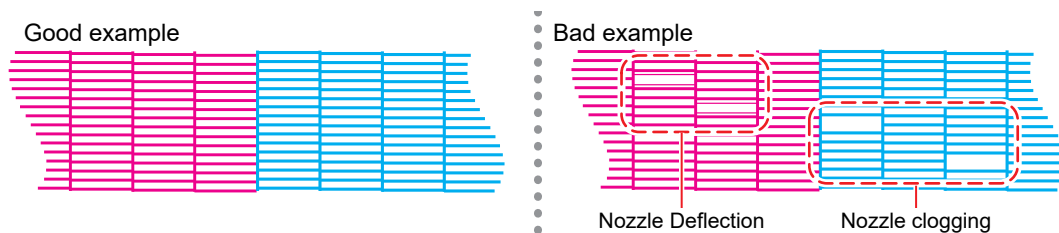

10. Clean the head to clear malfunctioning nozzles.

There are three different head cleaning methods. Choose the head cleaning method based on test print results.  ["Head Cleaning"\(P. 92\)](#)

11. Adjust the media feed amount.

☞ "Feed Correction"(P. 93)

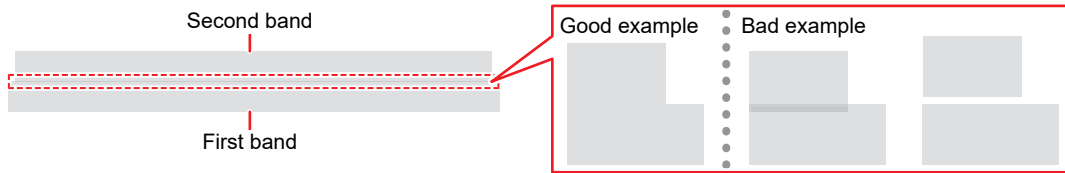

12. Adjust the drop position for bi-directional printing.

☞ "Correcting the Drop Position"(P. 95)

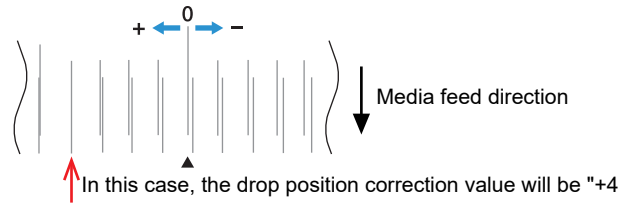

13. Preparing RIP data

☞ "Preparing RIP data"(P. 97)

14. Printing RIP data

☞ "Printing"(P. 99)

15. Cutting the media

☞ "Cutting the media"(P. 102)

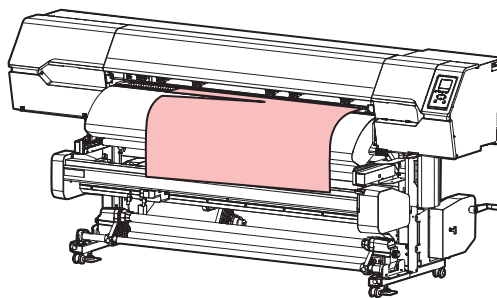

2.2 Adjusting Print Head Height

Adjust the height of the print head according to the thickness of the media you are using.

Range	Gap between print head and platen	
	JV/CJV/UCJV	TS
Low (recommended)	2.0 mm (default setting)	3.0 mm (default setting)
Middle	2.5 mm	3.5 mm
High	3.0 mm	4.0 mm



- Be sure to correct the dot position after altering the print head height.  "Correcting the Drop Position"(P. 95)



- With inkjet printers, if the gap between the print head and media increases, the ink droplets tend to vaporize before they reach the media. Vaporized ink may adhere to the print head nozzle surface and media, affecting print quality and causing failure of the print head. Adjust the print head height to suit the media.
- With the UCJV, more reflected light from the UV-LED unit hits the print head, which may cure any ink adhering to the nozzle face, increase the ink viscosity, and cause print head defects.

1 On the LOCAL mode screen, select [MENU] > [Maintenance], then press the [ENTER] key.

- The Maintenance menu is displayed.

2 Select [Station Maint.] > [Carriage Out] > [Move To Platen Right End], then press the [ENTER] key.

- The carriage moves over the platen.

3 Open the front cover.

4 Use the height adjustment lever to adjust the height.

- Set the height adjustment lever so that the desired height is at the top. If the lever is not set to the correct position, problems such as media jamming and misting may occur, resulting in impaired print quality.

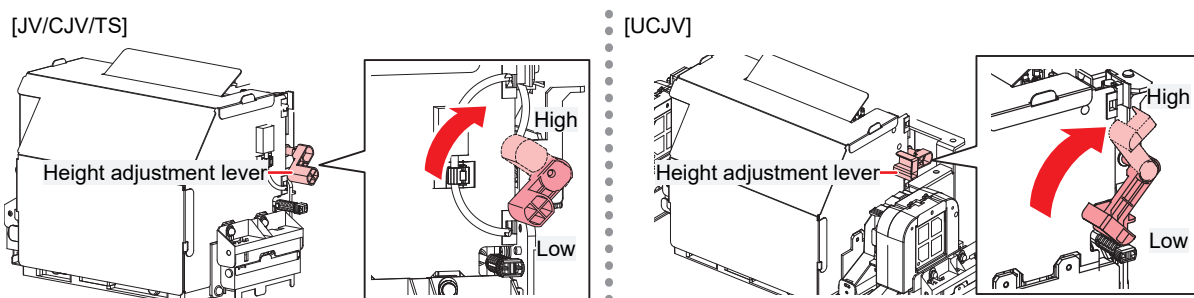

5 Once adjustment is complete, close the cover, then press the [ENTER] key.



- Check the head height indicated on the display. Readjust the height using the height adjustment lever if it is not at the set height.

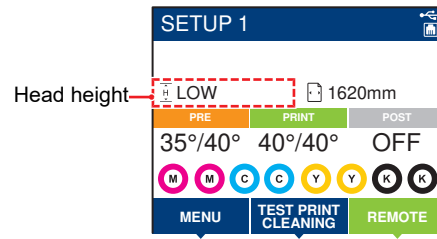

2.3 Adjust the Pinch Roller Positions.

CJV

UCJV



- The description here applies to the CJV/UCJV.

Adjust the pinch roller positions to suit the width of the media being used.

1 Choose the grit rollers capable of holding down the media at equal intervals.

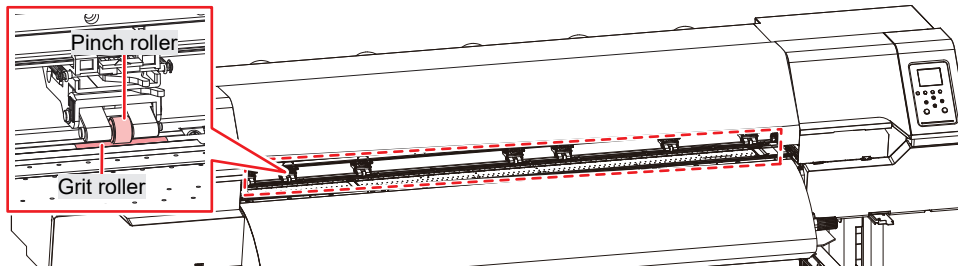

2 Move the pinch rollers above the grit rollers.

- Use the pinch roller guide marks as references.



- When adjusting from the front

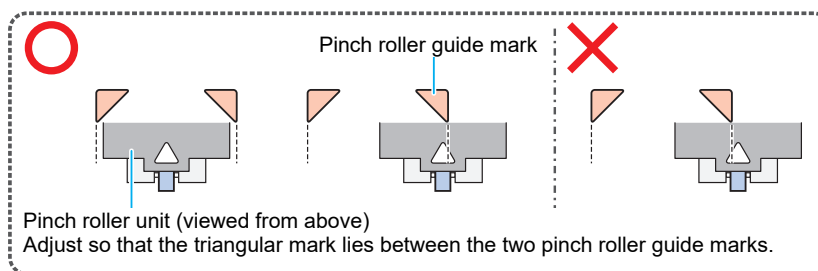

- When adjusting from the rear

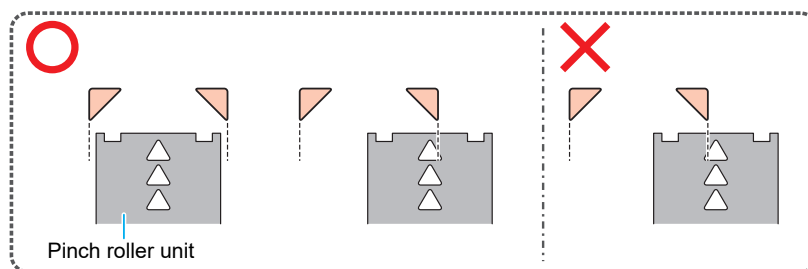

3 Align the pinch rollers at both the ends to within 10 cm from the left edges and 2 cm from the right edges of the media.

- Placement farther from the edges may leave some portions of the media uncut.

4 Remove the pinch rollers lying outside the media from the grit rollers.



- Feeding media with the pinch rollers and grit rollers in contact will cause pinch roller wear.

1,600 mm Size

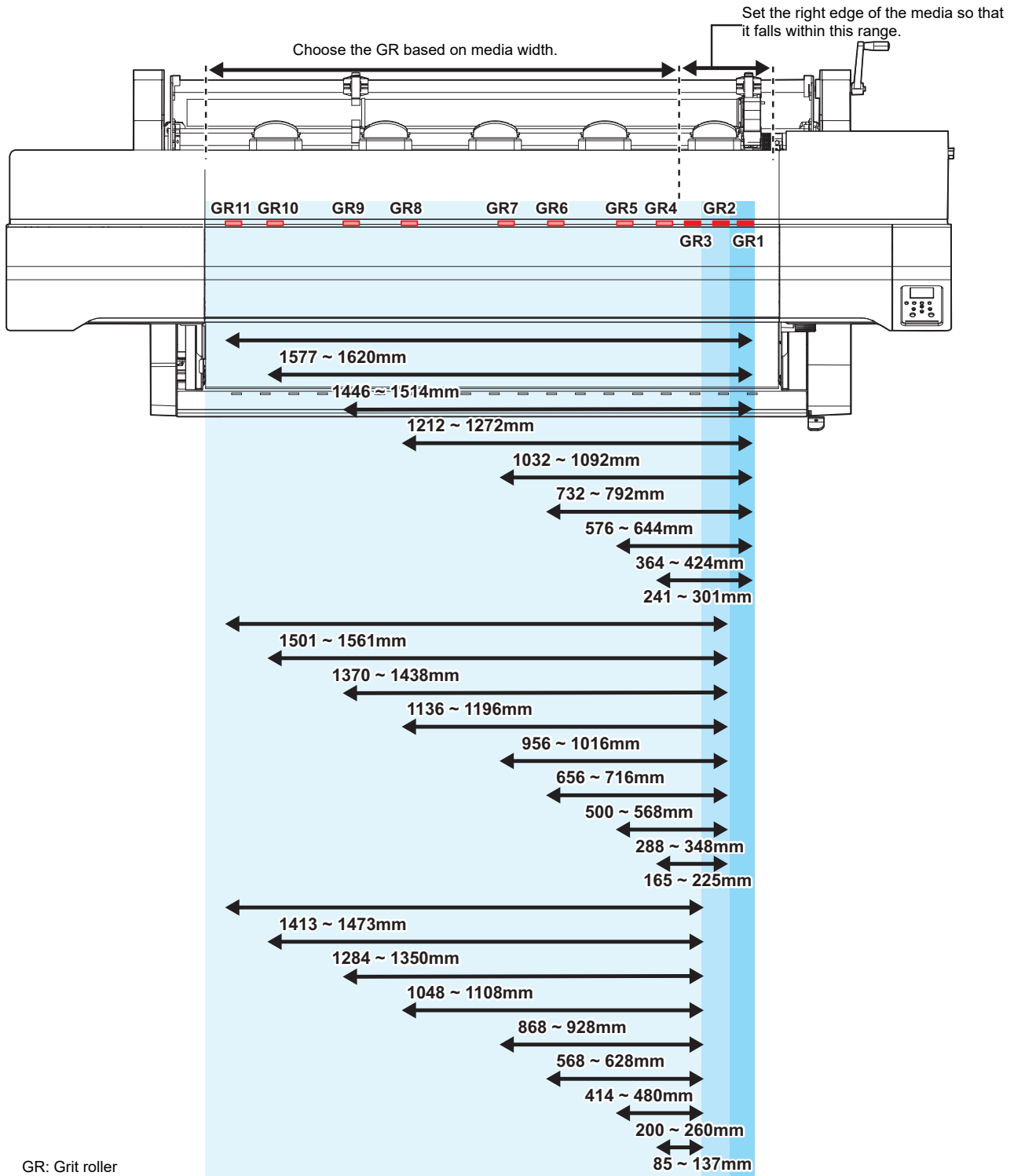

1,300 mm Size

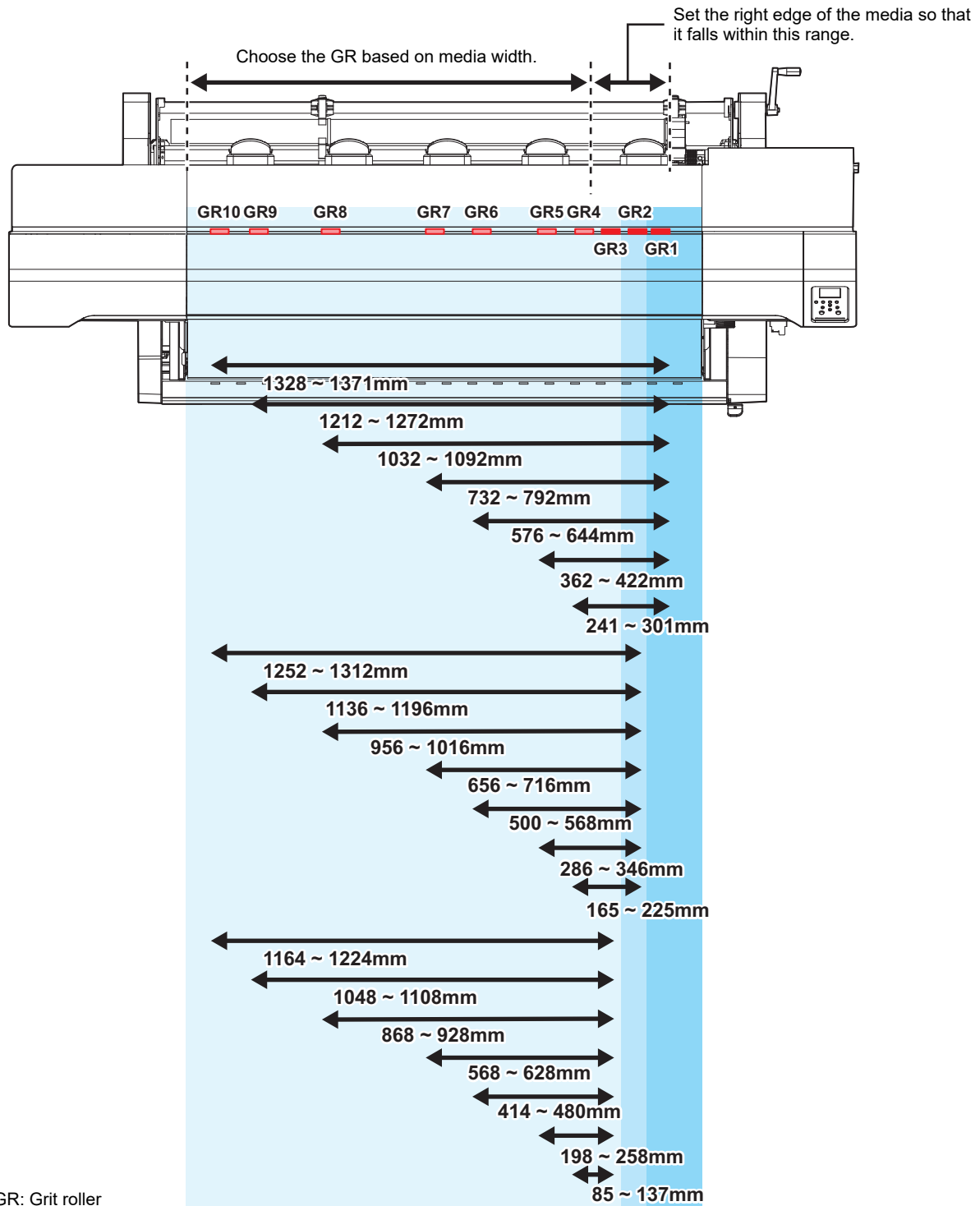

2.4 Loading the Media



- Adjust the head height before loading media. Moving the carriage after the media has been loaded may result in the print head coming into contact with the media and being damaged.

Media

● Media handling precautions



- Use Mimaki-approved media to ensure consistent high-quality printing.

WARNING



- Assign at least two people to load roll media. Otherwise there is a risk of back injury due to the weight of the media.

NOTICE



- Protect media from dust when stored. Otherwise print quality may be reduced.
- When storing standard-size media rolled up, store with the coated surface facing out.
- Static electricity countermeasures (such as ionizers, anti-static bars, water mist humidification, and alcohol-based anti-static agents) should be provided for the media. Do not use anti-static agents that contain surfactants.



- Do not leave the media in the machine when not in use. Otherwise dust may accumulate on the media. Do not use media that has been wiped free of dust. Wiping media can generate static electricity, possibly affecting print quality.
- Do not use media immediately after removing it from the package. The media may expand or contract depending on the temperature and humidity of the location in which it was stored. Allow the media to stand for at least 30 minutes in the same indoor environment as the machine before loading it.
- Do not use media if it is curled. Curled media may not only damage the print head, but may also affect print quality.
- When using UV ink, do not use media that reflects light, such as media containing gold or silver foil. Light reflected from the media surface may cure the ink on the print head, damaging the head. Please note that this is not covered by the warranty.



- The underside of the media may be soiled depending on how the printed media has been stored (due to weight when laying printed media rolls horizontally, for example) and the media type. Perform a test beforehand to check that the media does not transfer ink to the underside of the adjacent media.

Take-up unit

Use the switch on the take-up unit to change the media take-up direction.

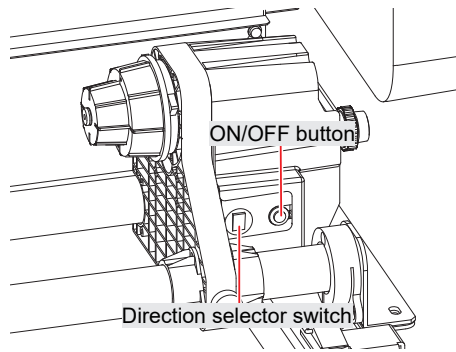

Name	Overview	
Direction selector switch	Up	To take up media with printed surface on the inside
	Down	To take up media with printed surface on the outside
ON/OFF button	Press the button to start/stop the take-up unit. The setting can be altered so that the take-up unit operates only while the button is depressed.  "Function Setting Menu"(P. 182)	

Adjusting the Torque Limiter

The left and right take-up units are fitted with a torque limiter.

Turn the torque limiter adjustment nut to adjust take-up tension. When adjusting the torque limiters, be sure to adjust to the same torque for both the left and right take-up units.

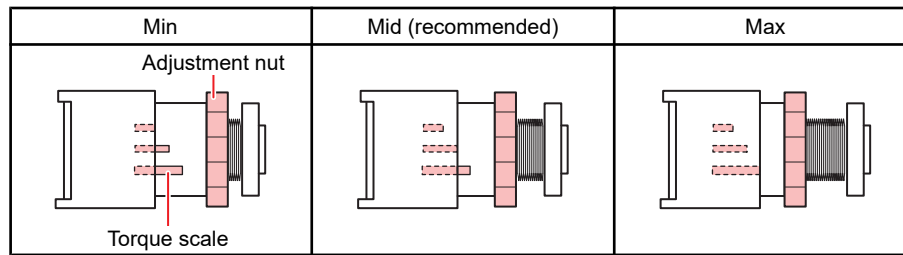

- For normal printing: Adjust the torque to "Mid".
- When using the XY slitter: Adjust the torque to "Max" if wrinkling occurs during slitting, or if thinner media is used.
- Depending on the media, increasing the torque may cause image defects due to the pinch roller and grit rollers failing to grip the media. Reduce the torque if the media slips.

● Increase tension (clockwise)

Increase tension when using with heavy or thick media, such as tarpaulin. Perform adjustments manually.

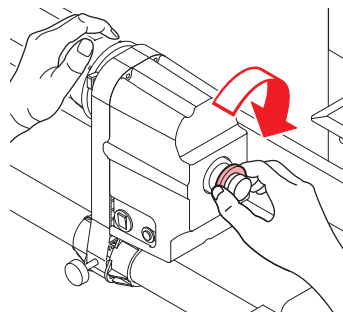

- Do not use the torque adjustment handle. Using the torque adjustment handle will cause overtightening. Overtightening may damage the take-up unit.

● Decrease tension (counterclockwise).

Decrease tension when using lightweight media. Use the "torque adjustment handle" provided.

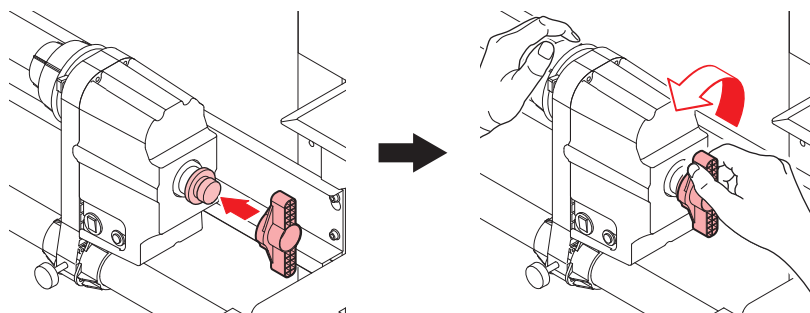

Replacing Printed Roll Media

The take-up unit can be replaced easily by pulling it out toward you.

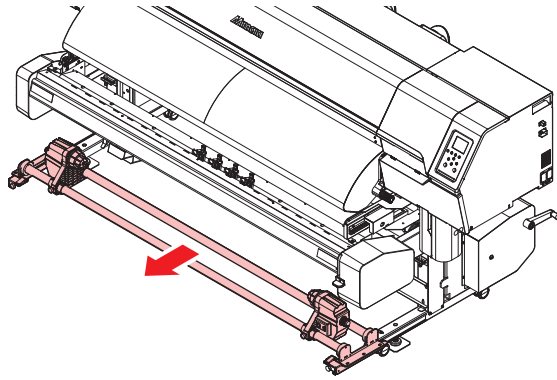

● Pull out the take-up unit

Release the latch and detach the hook.

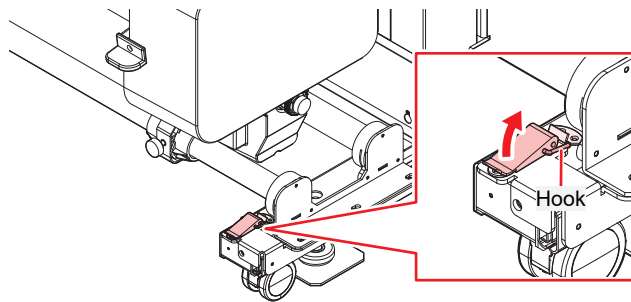

- There are latches on both sides of the take-up unit. Unlatch on both sides.

● Secure the take-up unit

Slide in the take-up unit fully, then secure the hooks on the latches, and lock the lever.

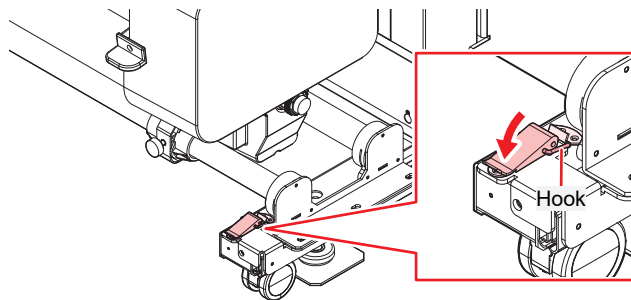

- There are latches on both sides of the take-up unit. Secure the hooks on both sides to lock them in place.

Using the Media Edge Guides

JV

CJV

TS

UCJV



- The description here applies to the JV/CJV/TS/UCJV*.
- Included as standard for the TS, and optional for the JV/CJV/UCJV.

Adjust the media edge guide positions to suit the roll media diameter.

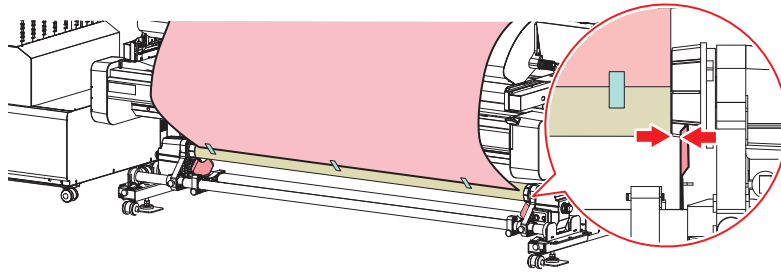

Media diameter	Distance between media edge guide and media edge
Not more than $\varnothing 120$ mm	1 mm
$\varnothing 121$ mm to $\varnothing 160$ mm	3 mm
$\varnothing 161$ mm to $\varnothing 200$ mm	5 mm

● Unlocking the Media Edge Guides

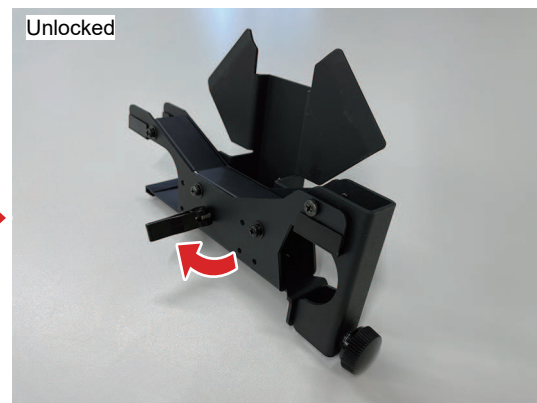
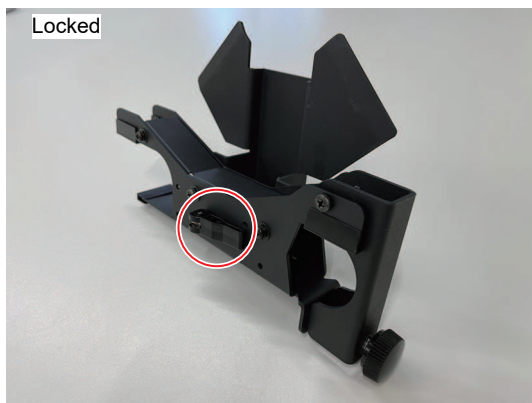

- The media edge guides can be moved up and down once they have been unlocked. These can be adjusted to the optimal positions to suit the diameter of the paper core.

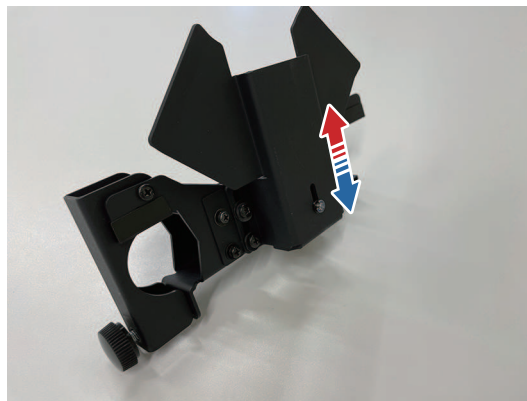

● Removing the Media Edge Guides

- 1 Turn the knob screw and open the media edge guide cover.

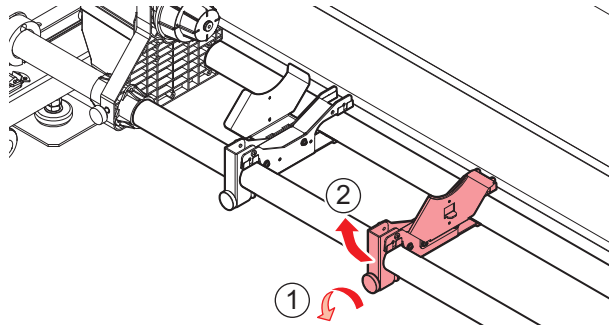

- 2 Rotate the media edge guides to remove them.

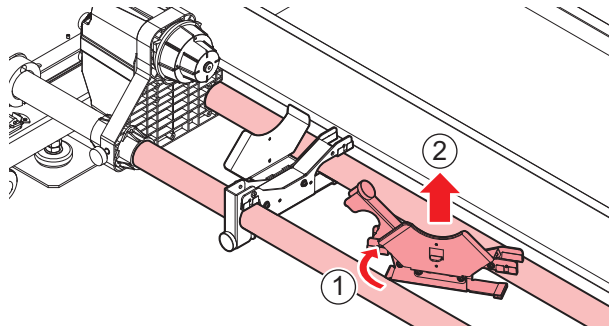

Feeding unit

Using the Media Stopper

When pulling out a fixed length of media by hand, the roll holder locks, stopping the media from being pulled out.

● Lock the media stopper

Push the side pin while pressing on the media stopper. Releasing the media stopper in this state locks the roll holder.

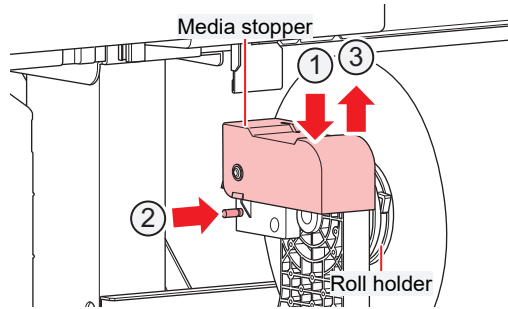

- Be sure to lock the media stopper when loading roll media or printing.

● Release the media stopper

Press the media stopper to release the roll holder.

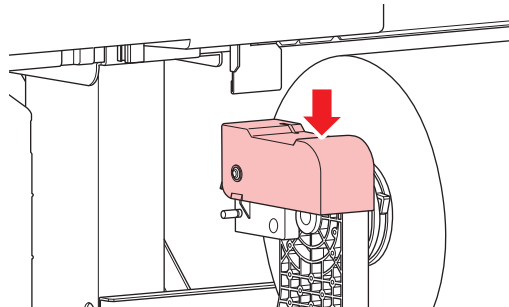

Roll Holder Setting Position

Loosen the knob screw on the rear left roll holder, then move it to the roll setting position.

● JV

A label showing the roll holder setting position is placed on the roll guide of the media changer. Use it as a reference to move the roll holder, then secure using the knob screw.

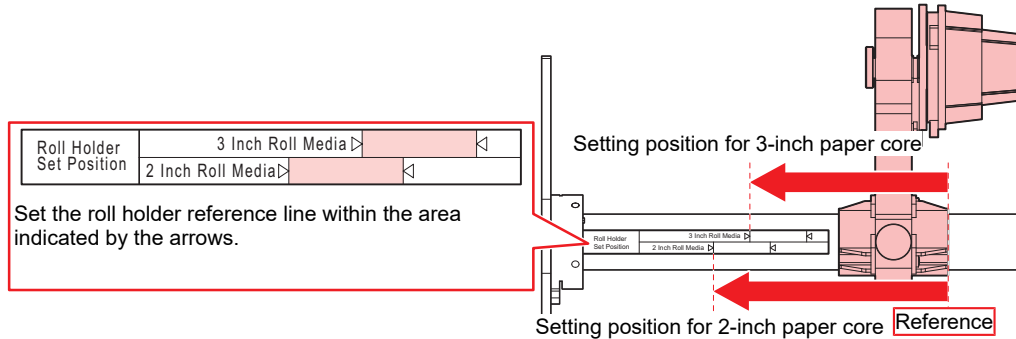

● CJV/UCJV

Use the pinch roller guide marks as references to move the roll holder, then secure using the knob screw.

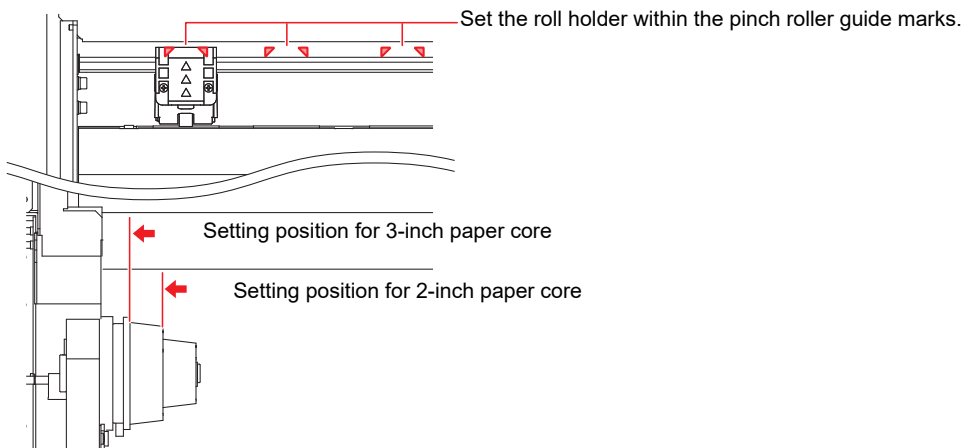

● TS

A label showing the roll holder setting position is placed on the leg stay. Use it as a reference to move the roll holder, then secure using the knob screw.

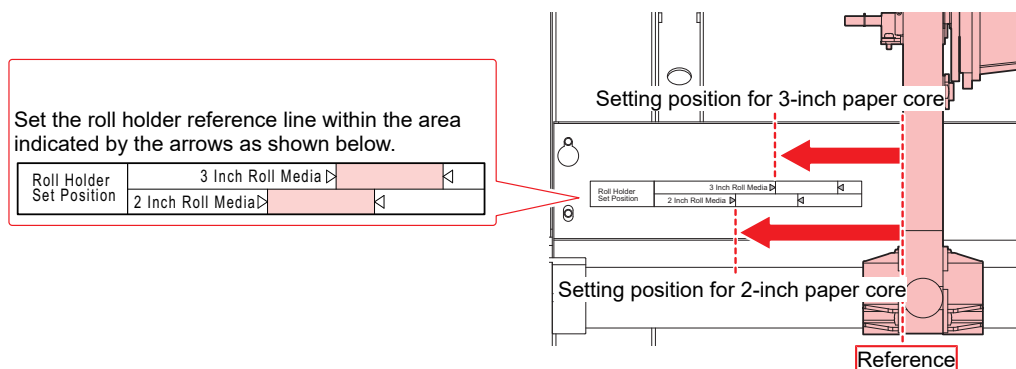

Media Changer

JV

CJV

UCJV



- The description here applies to the JV/CJV/(UCJV)*. (* "Options"(P. 286))

Three media rolls can be loaded. The media used can be switched by rotating the selection handle.

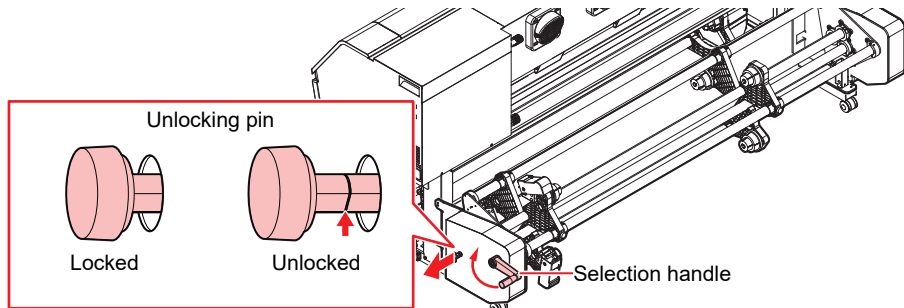

Name	Overview
Unlocking pin	<ul style="list-style-type: none"> Pulling out the unlocking pin unlocks and allows the selection handle to be rotated. If the unlocking pin is difficult to pull out, rotate the selection handle approximately 5 to 15 degrees counterclockwise before pulling out the unlocking pin. <div data-bbox="475 949 1008 1133" style="border: 1px solid black; padding: 5px; text-align: center;"> </div>
Selection handle	<ul style="list-style-type: none"> Rotate the Selection handle clockwise to select the media. Even if you hear a click while rotating the handle, it does not indicate that the media to be printed is selected. When the media is moved to the specified position, the handle automatically locks, preventing it from being rotated. <div data-bbox="475 1290 852 1478" style="border: 1px solid black; padding: 10px; text-align: center;"> <p>Rotation</p> </div>



- To select media successively, be sure to pull the unlocking pin to **unlock and rotate the selection handle**. Attempting to rotate the handle without unlocking it may result in damage.
- Rotate the selection handle slowly (approximately 2 seconds per revolution)**. Rotating it too quickly may cause it to spin.



- Do not position the media stopper where it might hit the leg. Otherwise, the media stopper may be damaged when you select media.  ["Using the Media Stopper"](#) (P. 72)

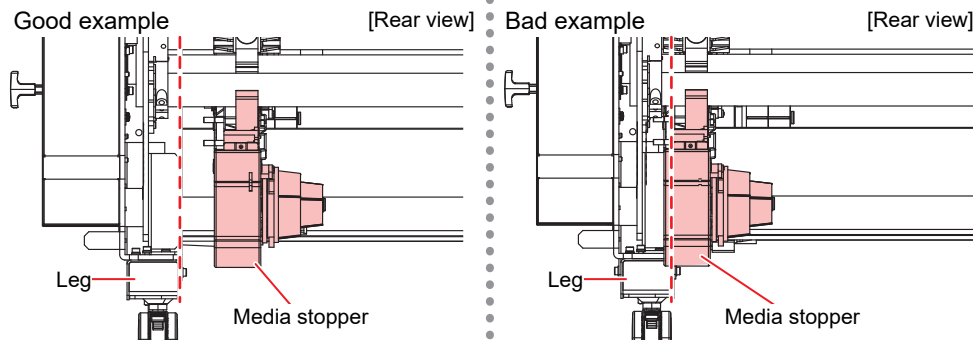

Loading the Roll Media

1 Raise the clamp lever.

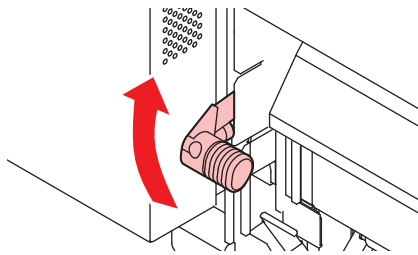

2 Move the rear left roll holder to the roll setting position.

- Unscrew the roll holder retaining screw, move the roll holder, then retighten the retaining screw.
☞ "Roll Holder Setting Position"(P. 73)

3 Insert the paper core of the roll media on to the rear left roll holder.

- Push in until the paper core moves no farther.

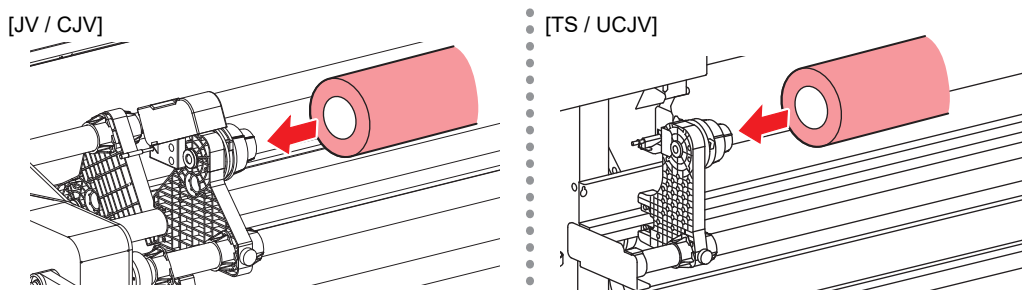

4 Insert the rear right roll holder into the paper core.

- Unscrew the roll holder retaining screw, move the roll holder, then retighten the retaining screw.

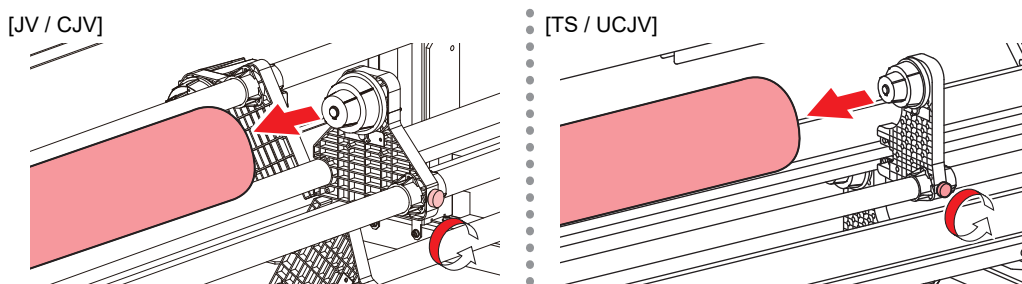

5 Insert the media between the pinch rollers and the grit rollers.



- Inserting the media at an angle allows smooth insertion without catching or sticking.

6 Lower the clamp lever.

- Hold the media with the pinch roller and grit rollers.

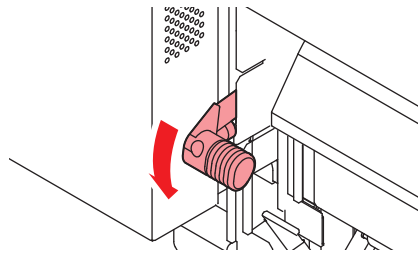

7 Lock the media stopper.

-  "Using the Media Stopper"(P. 72)

8 Move to the front of the machine and open the front cover.

9 Raise the clamp lever and pull out the media.

- Make sure the media does not fall to the rear.



- Adjust the rear roll holder position so that the media does not cover the right-hand slit line on the platen. Movement at an angle may result in damage to the print head.

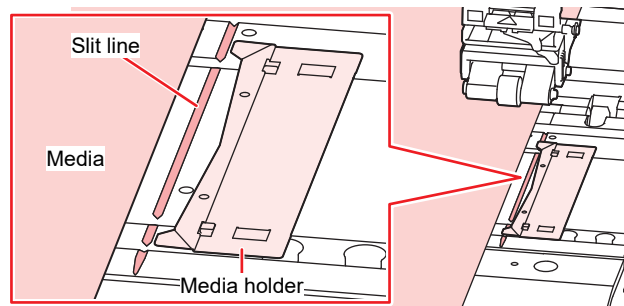

- The areas extending 5 mm from both sides of the media are margins.

10 (CJV/UCJV only) Lower the clamp lever and confirm that the pinch rollers are uniformly spaced.

-  "Adjust the Pinch Roller Positions."(P. 63)

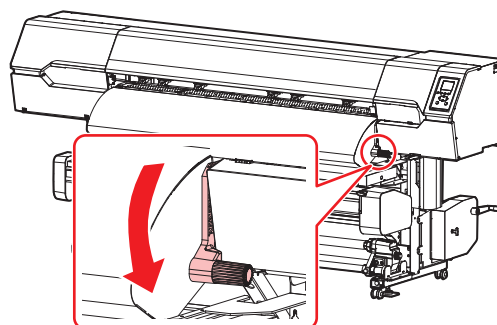

- If the spacing is not uniform, repeat all steps from the start.

11 (CJV/UCJV only) Raise the clamp lever.

12 Gently pull out the media and stop at the position where it is gently locked in place.

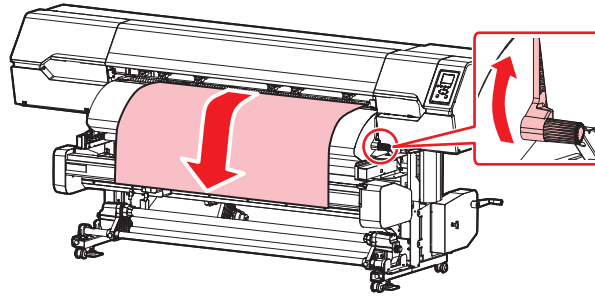

13 Check how far the media was pulled out.

- Pull the front edge of the media gently at several points to confirm that the media was pulled out by the same amount.

14 Lower the clamp lever.

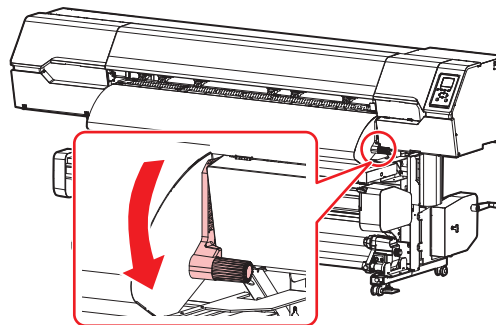

- Do not pull the media when the clamp lever is lowered (the media is clamped). Doing so may damage the machine.

15 Secure the media in the media holder.

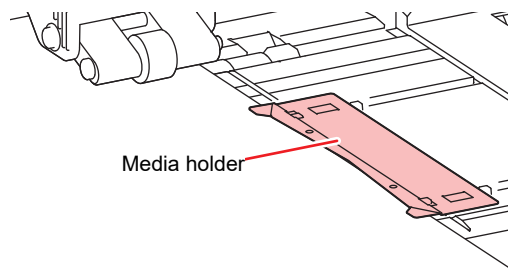

- Do not use the media holder when printing on thicker media.
- Do not use the media holder when cutting media.

16 Close the front cover.

17 Select the media to be used.

Media selection	1/2
• PVC	1300 mm
○ Tarpaulin	1600 mm
○ Unregistered	
○ Unregistered	
○ Unregistered	



- To use unregistered media, select [Unregistered] to register the media. "Registering the Media"(P. 85)

18 Detect the media width.

- No change: Only the right side of the media is detected.
- Media width re-detection: The media width is detected.

PVC	
Media Width	1300 mm
	No change Media width



- Media width may not be detected correctly for certain colors or types of media. When media width cannot be detected correctly, set the media width detection method to "MANUAL".
- If the media width detection method is set to "MANUAL", set the media width manually ([MENU] > [Media Setting] > [Media Information] > [Media Width] > [Detection Type] P. 175).
- A notification reading "Media Set Position R" will appear after media width detection if the media is too far to the right of the specified position. Reload media in the specified position.
- If Media Remain Manage is set to "ON", the Input Media Length screen will be displayed. ([MENU] > [Media Setting] > [Media Information] > [Media Remain] > [Media Remain Manage] P. 175).

19 (CJV/UCJV only) Enter the number of pinch rollers being used.

- If the setting for [Function Setting] > [Use PR Number Query] is "OFF", the screen for entering the number of pinch rollers will not be displayed.

20 Load an empty paper core on the take-up unit.

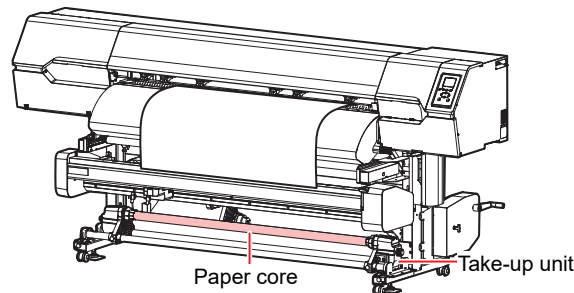

- Use the take-up unit for media with low stiffness (such as tarpaulin). If not, the media may rise up on the platen and damage a print head.

21 Press to feed the media until it reaches the paper core on the take-up unit, then press the [ENTER] key.



- Do not put media through the XY slitter.

22 Secure the middle of the media to the paper core with adhesive tape.

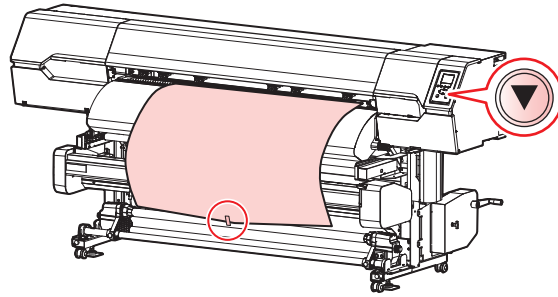

Important!

- If the media edge is straight, secure the left and right sides of the media. Pull the lower edge of the media evenly on both the left and right sides, check to confirm that it is free of sagging and creasing, then affix the tape.

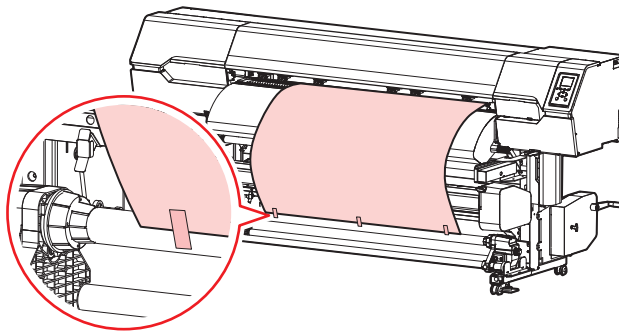

23 Press to wrap the media about one and a half turns around the paper core, then press the [ENTER] key.



- Move the take-up unit to the left or right when it is not in use. Print quality may be affected if the front edge of the media hits the take-up unit.

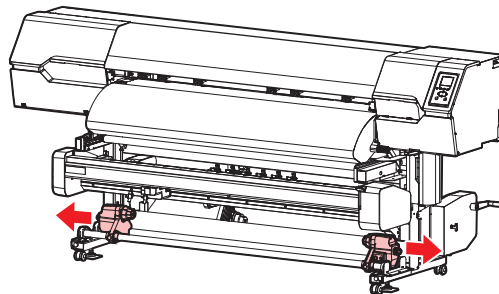

Setting Leaf Media

CJV

UCJV



- The description here applies to the CJV/UCJV.



- Move the take-up unit out of the way to the left and right when it is not in use. Print quality may be affected if the front edge of the media hits the take-up unit.

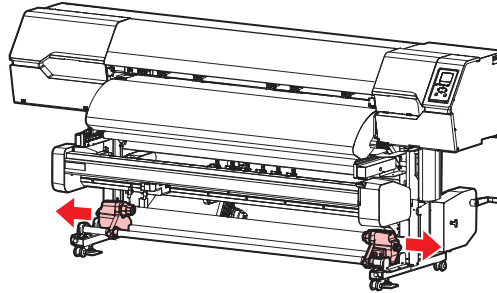

- On the LOCAL mode screen, select [MENU] > [Media Setting], then press the [ENTER] key.
 - The Media Setting menu is displayed.
- Select [Media Information] > [Media Operation Form] > [Leaf], then press the [ENTER] key.



- The media bottom end will not be detected if Leaf is not selected.

- On the LOCAL mode screen, select [MENU] > [Media Setting], then press the [ENTER] key.
- Raise the clamp lever.

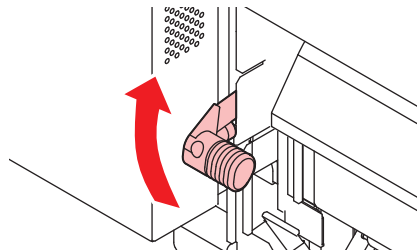

- Open the front cover.
- Insert the media.
 - Insert into the gap between the pinch rollers and the grit rollers.



- Inserting the media at an angle allows smooth insertion without catching or sticking.

7 Adjust the position of the right media edge.

- Set the media straight so that the media does not lie beyond the slit line on the platen.

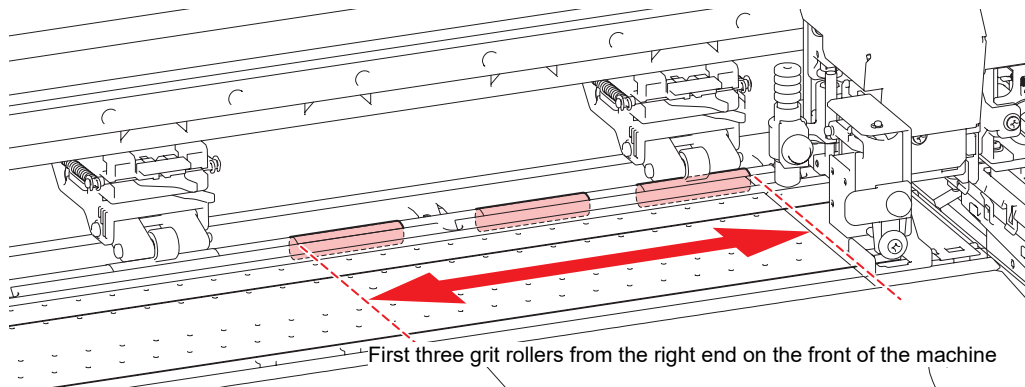

- The areas extending 5 mm from both sides of the media are margins.

8 Adjust the position of the front media edge.

- Set the media so that about 40 mm of it lies on the after cover. If not, the media width may not be detected.

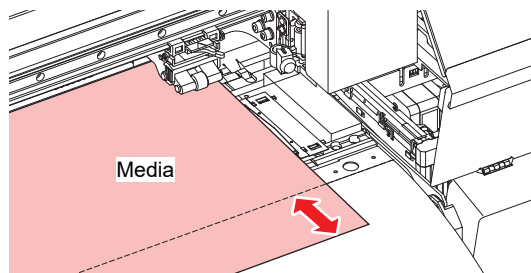

9 Lower the clamp lever to confirm that the spacing from the pinch roller is uniform.

- Hold the media with the pinch roller and grit rollers.
-  ["Adjust the Pinch Roller Positions."\(P. 63\)](#)

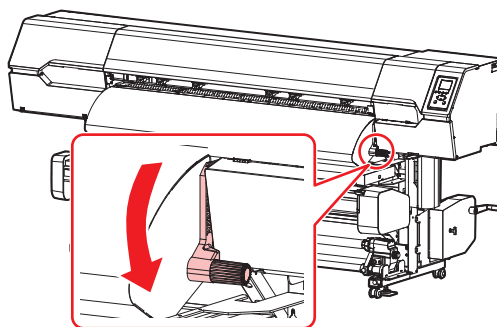

- If the spacing is not uniform, repeat all steps from the start.

10 Secure the media in the media holder.

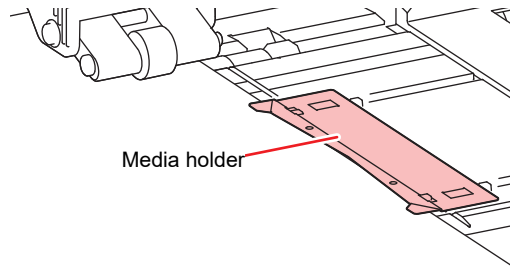

- Do not use the media holder when printing on thicker media.
- Do not use the media holder when cutting media.

11 Select the media to be used.

Media selection	1/2
<input checked="" type="radio"/> PVC	1300 mm
<input type="radio"/> Tarpaulin	1600 mm
<input type="radio"/> Unregistered	
<input type="radio"/> Unregistered	
<input type="radio"/> Unregistered	



- To use unregistered media, select [Unregistered] to register the media. ["Registering the Media"\(P. 85\)](#)

12 Detect the media width.

- No change: Only the right side of the media is detected.
- Media width re-detection: The media width is detected.

PVC	
Media Width	1300 mm
	No change
	Media width



- Media width may not be detected correctly for certain colors or types of media. When media width cannot be detected correctly, set the media width detection method to "MANUAL".
- If the media width detection method is set to "MANUAL", set the media width manually ([MENU] > [Media Setting] > [Media Information] > [Media Width] > [Detection Type] P. 175).
- A notification reading "Media Set Position R" will appear after media width detection if the media is too far to the right of the specified position. Reload media in the specified position.

13 Detect the media bottom.

- Select [Execute].

Media detect
Start detecting the media trailing edge.
Execute
Not execute

14 Enter the number of pinch rollers being used.

- If the setting for [Function Setting] > [Use PR Number Query] is "OFF", the screen for entering the number of pinch rollers will not be displayed.

Registering the Media

When the clamp lever is lowered with media being loaded, the Select Use Media screen is displayed. Registration is required to use media that is not registered on the machine.



- To set print conditions for a single use, select "Temporary". The conditions set in "Temporary" are cleared when the machine is restarted.

1 Select [Unregistered].

Media selection	1/2
<input checked="" type="radio"/> PVC	1300 mm
<input type="radio"/> Tarpaulin	1600 mm
<input type="radio"/> Unregistered	
<input type="radio"/> Unregistered	
<input type="radio"/> Unregistered	

2 Select the media type.

Media Type
<input checked="" type="radio"/> PVC
<input type="radio"/> Tarpaulin
<input type="radio"/> Transfer paper
<input type="radio"/> Illuminated Film
<input type="radio"/> Cutting Sheet

3 Select the media width detection type.

- AUTO: The media width is automatically detected.
- MANUAL: The media width is manually set.

Media Detection Type
Please Select.
AUTO
MANUAL



- Media width may not be detected correctly for certain colors or types of media. When media width cannot be detected correctly, set the media width detection method to "MANUAL".

4 (CJV/CJV only) Select the media form.

- Select whether roll media or leaf media is used.

Media Operation Form
Please Select.
Roll
Leaf



- When [Roll] is selected, the Media Remain Manage screen is displayed.

5 Select the method for managing the media remaining amount.

- Select whether or not to manage the media remaining amount with the machine.

Media Remain Manage	
Please Select.	
	ON
	OFF

6 Enter the name to be displayed.

- If you do not register the name, press the [ENTER] key.

Media Name Change
Media 3
will be changed
(maximum 10 characters)

7 Select whether or not to register the set information.

do you optimize setting?	
	Execute
	Do not



- You can change the settings later. ["Media Setting Menu"\(P. 174\)](#)
-

2.5 Setting the Pressure and Number of Pinch Rollers to Use

CJV

UCJV



- The description here applies to the CJV/UCJV.

Set the pressure and number used to hold media based on the tool and media being used. Incorrect pinch roller pressure settings may result in media skew or leave pinch roller marks on the media.

1 On the LOCAL mode screen, select [PR].

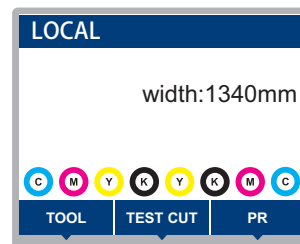

2 Make settings based on the tool and media used.

- The following items can be configured:
- The settings are retained even when the power is turned off.

Item	Setting	Overview
Number for Use	160: 2–7 130: 2–6	Sets the number of pinch rollers to use.
Print	LOW/MID/HIGH	Sets the pressure used for printing. <ul style="list-style-type: none"> Recommended value (normal): MID
Cut:Ends	LOW/MID/HIGH	Sets the pressure for both the pinch rollers on the edges (left and right) used for cutting. <ul style="list-style-type: none"> Recommended value (normal): HIGH
Cut:Inner	OFF/LOW/MID/HIGH	Sets the pressure for the pinch rollers used for printing other than those on the edges. <ul style="list-style-type: none"> Recommended value (normal): HIGH <ul style="list-style-type: none"> To reduce pinch roller marks, change to MID or LOW. Note that this may reduce cutting accuracy.
Pullback setting: Ends * UCJV only	LOW/MID/HIGH	Sets the pressure for both the pinch rollers on the edges (left and right) used for multi-layer printing. All of the other pinch rollers are raised to avoid leaving roller marks on the printed surface. Allows only "White ink → Color + Gloss" printing to be used. For more information, refer to the "RasterLink Reference Guide" or "Clear Ink Print Guide".
Change Execution	-	Used to check settings. Switch to configured settings before printing the built-in pattern (e.g., test printing, test cutting).



When the machine is not in use, raise the clamp lever to separate the pinch rollers from the grit rollers.

- Leaving the pinch rollers lowered may cause them to become deformed and prevent media from being fed correctly.
 - Leaving media loaded will subject it to force from the pinch rollers, which may leave pinch roller marks on it.
-

2.6 Setting the Heater Temperature

Set the heater temperature to suit the type of media used. The temperature can be altered while printing is in progress, but this may cause color variations to occur.





- Adjust the heater temperature to suit the media type and characteristics. Depending on the type, the media may expand or shrink or become rippled.



- The temperature setting in the RIP software takes precedence. If you are using the Mimaki RIP software (RasterLink), the recommended values are stored in the color profile.

Name	Overview
PRE (Preheater)	Preheats the media before printing to suppress rapid temperature change.
PRINT (Print heater)	Helps prevent ink bleeding.
POST (Post-heater)	Allows ink to dry after printing. <ul style="list-style-type: none"> • The temperature at the lower part of POST is lower than the upper part.



- TS: Only equipped with a post-heater. (The print heater is optional  "[Options](#)"(P. 286).)
- UCJV: Only equipped with a pre-heater. (The print heater and post-heater can be installed as options  "[Options](#)"(P. 286).)

1 On the LOCAL mode screen, select [HEATER].

- The Heater Temperature Setup screen appears.

2 Enter the heater temperatures, then press the [ENTER] key.

- Printing is possible once the heater temperatures reach the temperature settings ± 3 °C.

2.7 Test Printing

Print a test pattern to confirm that the ink prints correctly. Perform head cleaning if you observe any ejection failures (e.g., nozzle clogging or deflection). 🖨️ ["Head Cleaning"](#)(P. 92)

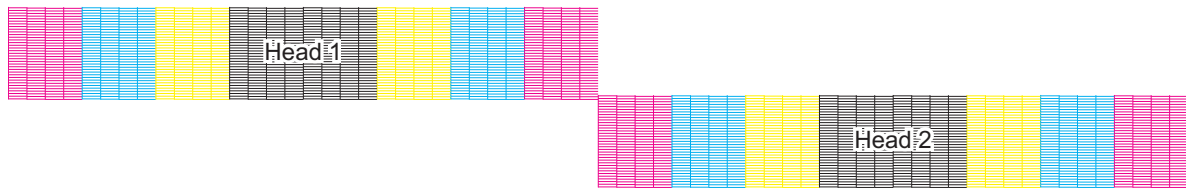

Check beforehand

- Was the print head adjusted? 🖨️ ["Adjusting Print Head Height"](#)(P. 61)
- Is media loaded? 🖨️ ["Loading the Media"](#)(P. 66)



- Load media at least 500 mm wide. You cannot print the entire pattern if media less than 500 mm wide is used.



- Select [Maintenance] > [Nozzle Recovery] > [Test Print], then select "ON" to perform nozzle recovery and test printing. Registration is required to perform nozzle recovery. 🖨️ ["Registering Nozzle Recovery"](#)(P. 179)
- The ink used in the UCJV is warmed before printing. Printing is disabled while the ink is warmed.

Changing the Layout Direction for Test Printing

You can change the layout direction for test printing.

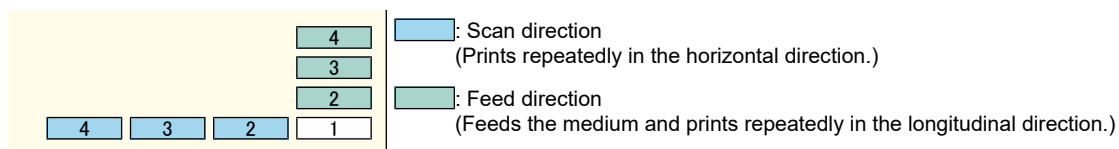

- 1 On the LOCAL mode screen, select [TEST PRINT/CLEANING] > [Test Print], then press the [ENTER] key.
 - The Test Print menu is displayed.
- 2 Select [Scan Dir.] or [Feed Dir.], then press the [ENTER] key.
 - Test printing starts.

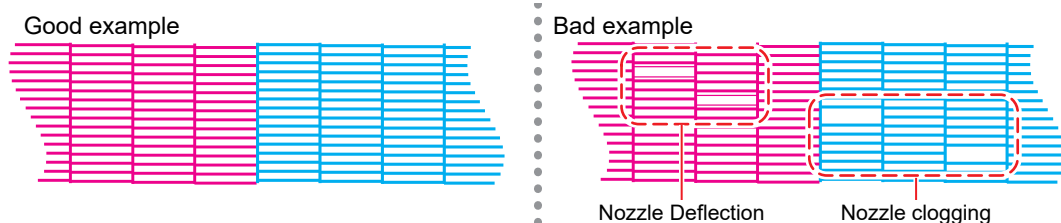

- 3 Check the print results.

Checking White Ink Ejection

The following two methods are available for checking white ink:

- Print on clear film.
- Print the background for the test pattern using black ink.

● Method for printing the background using black ink

1 On the LOCAL mode screen, select [TEST PRINT/CLEANING] > [Test Print], then press the [ENTER] key.

- The Test Print menu is displayed.

2 Select [SpotColor Check], then press the [ENTER] key.

- Test printing starts.
- The layout direction is fixed at [Scan direction].

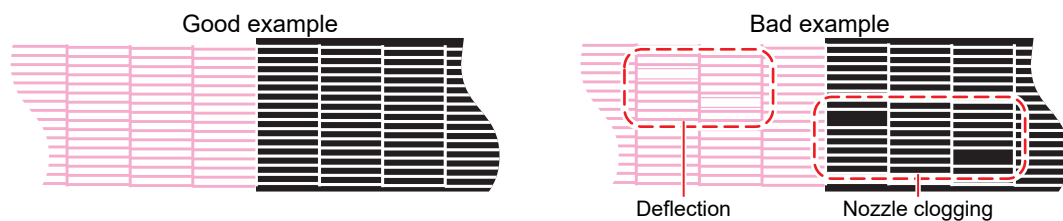

3 Check the print results.

Ejection Failures

Typical examples of ejection failures (e.g., nozzle clogging, deflection) are as shown below. In order to prevent printing in such a state, check whether the ink has been properly ejected regularly before printing.

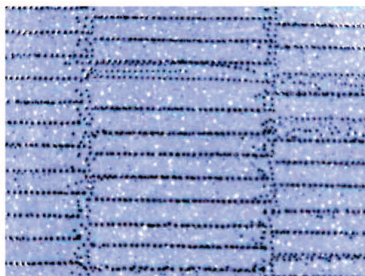

Nozzle Deflection



Nozzle clogging



Ink drips



Mist

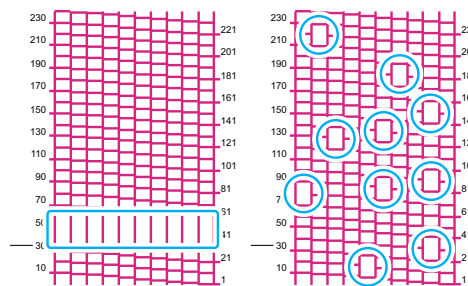

Mixed air

2.8 Head Cleaning

The following head cleaning methods are available. Choose the method based on test results. Cleaning is not possible when the [Ink Near End] or [Ink End] errors are displayed. Replace with new ink.  "Replacing Ink"(P. 46)

Item	Details
Soft	If the print shows a bent line (Nozzle deflection)
Normal	If the print shows a missing line (nozzle clogging)
Hard	If soft cleaning and normal cleaning fail to resolve ejection failures (e.g., nozzle clogging or deflection).
Wash Wiping *JV/CJV/TS only	If hard cleaning fails to resolve ejection failures (e.g., nozzle clogging or deflection) or color mixing <ul style="list-style-type: none"> Wash Wiping cannot be performed if an error ([Wash Liquid End] or [WashLiquidCart.None]) is displayed. Load a maintenance liquid cartridge containing liquid.



UCJV:

- The ink used in the UCJV is warmed before printing. Printing and cleaning is disabled while the ink is being warmed.





UCJV

- If there is considerable nozzle clogging with white ink (dropouts), perform Air PG.  "There is considerable nozzle clogging with white ink"(P. 254)



- 1 On the LOCAL mode screen, select [TEST PRINT/CLEANING] > [Cleaning], then press the [ENTER] key.**
 - The Cleaning menu is displayed.
- 2 Select the cleaning type, then press the [ENTER] key.**
- 3 Select the Head to clean, then press the [ENTER] key.**
 - Check the check box. Heads with checked check boxes will be cleaned.
- 4 Run another test print and check the print results.**
 - Repeat the cleaning and test printing process until the print results appear normal.



- Do the following if head cleaning fails to resolve the ejection failures (e.g., nozzle clogging or deflection).
 -  "Cap Rubber Cleaning"(P. 198)
 -  "Print Head Nozzle Washing"(P. 253)
- Perform the following steps if an abnormal noise is heard during cleaning:
 -  "Abnormal noise occurs during cleaning"(P. 257)

2.9 Feed Correction

Changing the media may affect the feed amount due to various factors, including the weight and thickness of the media and whether the take-up unit is used. Correct the drop position to suit the type of media used. Image defects (e.g., dark or light streaks) will result if the feed is not properly corrected.

Check beforehand
<ul style="list-style-type: none"> • Is media loaded?  "Loading the Media"(P. 66) • Does the heater temperature suit the media to be used?  "Setting the Heater Temperature"(P. 89) • For roll media, is the rear roll media free of sagging? • When using the take-up unit, is the media mounted on the paper core of the take-up unit?  "Loading the Roll Media"(P. 76)



UCJV:

- The ink used in the UCJV is warmed before printing. Printing and cleaning is disabled while the ink is being warmed.

● Pullback printing

UCJV



- The description here applies to the UCJV.

[Feed Comp.(pull-back)] adjustment must be performed before using pullback printing. The correction value will be applied when pullback printing is performed.



- For more information, refer to the "UCJV300/UCJV330 Clear Ink Print Guide". <https://mimaki.com/download/software.html>

The adjustment method is the same as for [Feed Comp.].  "Feed Correction Procedure"(P. 93)

● Performing [[Feed Comp.(pull-back)]] causes the following actions:

- (1) Media forward/backward feeding starts.
 - The media will become slack.
- (2) A correction pattern is printed.

Feed Correction Procedure

Print a correction pattern, then enter the correction value. The value corrected here will also be updated on the Media Setting menu.



- When using the take-up unit, load media on the take-up unit before correcting.

1 On the LOCAL mode screen, select [ADJUST].

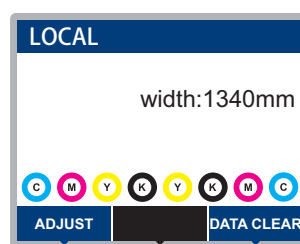

2 Select [Feed Comp.], then press the [ENTER] key.

- Correction pattern printing starts.

3 Check the print results.

- A correction value input screen appears.
- Adjust the bands so that the region between them is evenly colored.

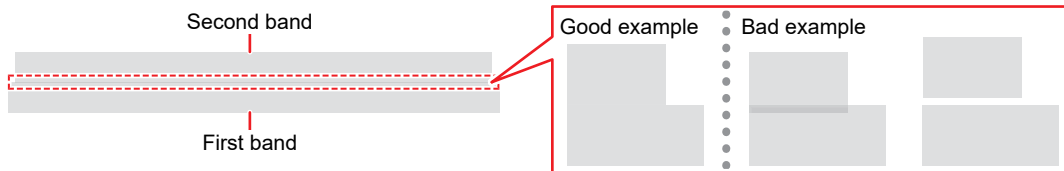

4 Enter the correction value, then press the [ENTER] key.

- "+" input: Increases the separation between bands.
- "-" input: Reduces the separation between bands.
- Increment the correction value by "30" to move the bands by approximately 0.1 mm.

5 Press the [ENTER] key.

- Print another correction pattern to check.



- Once adjustment is complete, the medium will be fed to the print origin. Sagging may occur in the rear roll medium. Rewind roll media by hand to eliminate any sagging.

Correcting the Media Feed During Printing

You can also correct the media feed amount in REMOTE mode or during printing.

1 Press [ADJUST] in REMOTE mode or during printing.



2 Enter the correction value, then press the [ENTER] key.

- Correction value: -9999 to 9999
- The value entered here will be updated immediately.

2.10 Correcting the Drop Position

Changing the media and print head height and temperature changes around the print head will also alter the drop positions. Correct the drop position to suit the type of media used. Image defects (e.g., overlaid lines or blurred images) will result if the drop position is not properly corrected.

Check beforehand

- Was the print head adjusted?  ["Adjusting Print Head Height"\(P. 61\)](#)
- Is media loaded?  ["Loading the Media"\(P. 66\)](#)
- **Does the heater temperature suit the media to be used?**  ["Setting the Heater Temperature"\(P. 89\)](#)



- Load media at least 500 mm wide. You cannot print the entire pattern if media less than 500 mm wide is used.



UCJV:

- The following screen display indicates that the print head is being warmed. Printing starts once the proper temperature is reached.

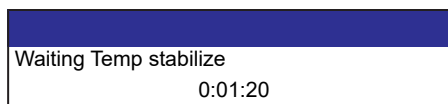

- Printing can be started without waiting for the print head to reach the proper temperature by pressing the [ENTER] key while the screen is displayed, but dot printing may be offset.

Drop Position Correction Procedure

Print a correction pattern, then enter the correction value. The value corrected here will also be updated on the Media Setting menu. This must be adjusted for each print resolution.

- 1 On the LOCAL mode screen, select [ADJUST].

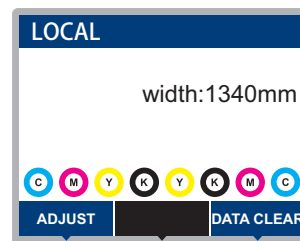

- 2 Select [Drop.PosCorrect], then press the [ENTER] key.

- 3 Select the resolution, then press the [ENTER] key.

- Select the resolution to be adjusted. When "All" is selected, correction patterns for all resolutions will be printed.  ["Media Setting Menu"\(P. 174\)](#)



- The indicated resolutions are those in the scan direction.

4 Check the print results.

- A correction value input screen appears.
- Enter the position where the two upper and lower lines coincide.

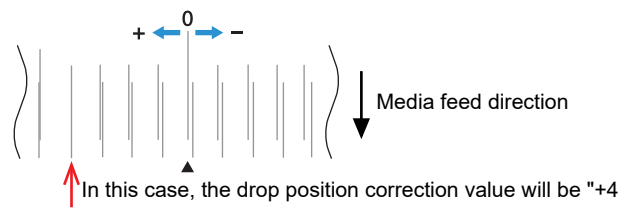

5 Enter the correction value, then press the [ENTER] key.

- Correction value: -40 to 40



- If the lines do not coincide when the correction value is within the range -40 to 40, the print head height may have been improperly adjusted. Adjust the print head height. ["Adjusting Print Head Height"\(P. 61\)](#)

6 Enter the correction value in the same way for pattern 2 and subsequent patterns.

2.11 Preparing RIP data

The explanation here applies to MIMAKI RIP software (RasterLink).

- Important!**
- If using TxLink, refer to the TxLink operating manual.

- Prepare suitable image data for printing.

1 Launch RasterLink.

- Click the icon on the PC desktop.



2 Select the image data to print.

- (1) Select [File] > [Open].
- (2) Select the desired image data, then click [Open].
 - If multiple printers are registered, select 330 Series in "Printer Name".

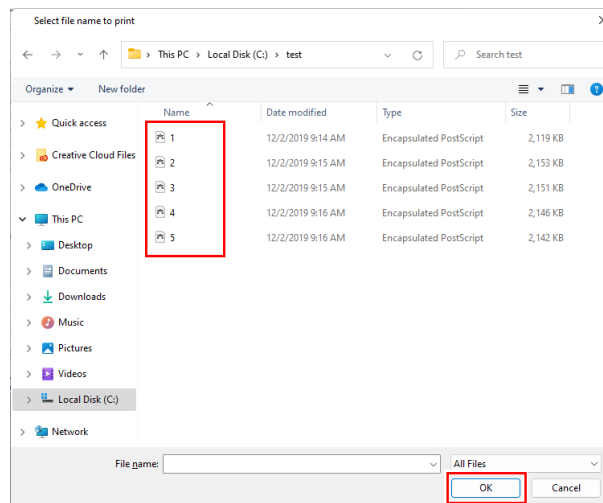

3 Select the image data imported.

- The image data is added in the tab for 330 Series selected in "Printer Name".

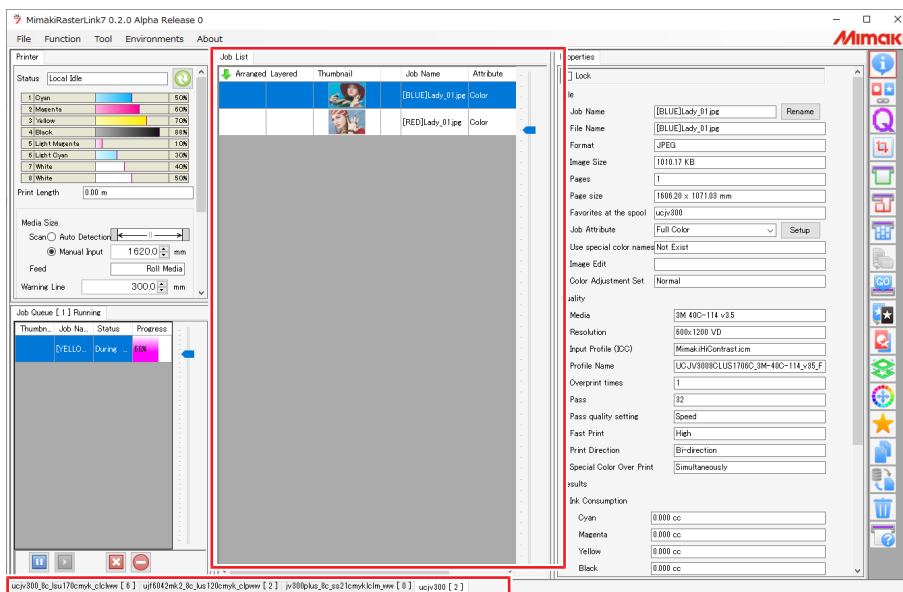

4 Edit the image.

- Specify the following settings by clicking the function icons shown on the right-hand side of the screen:



(General Print): Specifies settings like enlargement/reduction and rotation.



(Quality): Selects a color profile for the media and ink set loaded in this machine.



- For more information, refer to the RasterLink reference guide. <https://mimaki.com/download/software.html>

5 Print image data.

- "Starting Printing"(P. 100)

- Click (Execution) from the function icons on the right-hand side of the screen.
- Select "Immediate Print" or "RIP and Print", then click [Start].



- Media width must be reacquired after replacing media.
 - Select the tab for 330 Series in the main window.
 - Click (Update the printer status) in the Printer tab.

2.12 Printing

Check beforehand

- Was the print head adjusted? 🖱️ ["Adjusting Print Head Height"\(P. 61\)](#)
- (CJV/UCJV only) Were the pinch roller positions adjusted? 🖱️ ["Adjust the Pinch Roller Positions."\(P. 63\)](#)
- Is media loaded? 🖱️ ["Loading the Media"\(P. 66\)](#)
- (CJV/UCJV only) Was the pinch roller pressure adjusted? 🖱️ ["Setting the Pressure and Number of Pinch Rollers to Use"\(P. 87\)](#)
- For roll media, is the rear roll media free of sagging?
- When using the take-up unit, was the media mounted on the paper core of the take-up unit? 🖱️ ["Loading the Roll Media"\(P. 76\)](#)



- Condensation may form on the print head nozzle surface depending on the ambient temperature and humidity. The formation of condensation may cause ejection failures (e.g., nozzle clogging or deflection). Perform head cleaning if any ejection failures (e.g., nozzle clogging or deflection) occur during printing. 🖱️ ["Head Cleaning"\(P. 92\)](#)
Set the platen heater to a temperature not exceeding 35 °C, and ensure that the ambient temperature is within the permissible operating temperature range (20 to 30 °C). 🖱️ ["Installation Precautions"\(P. 18\)](#)

Changing the Origin

The print start position can be altered. Use the LED pointer to set the origin.

- Print origin default value
 - Feed (longitudinal, X') direction: Approx. 75 mm to rear from platen cutting slot
 - Scan (lateral, Y') direction: 15 mm from right edge of media

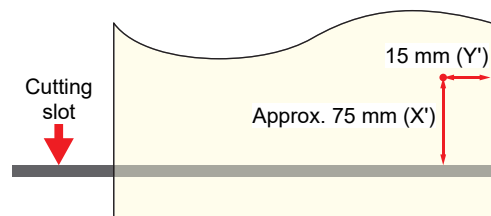

- 1** On the **LOCAL** mode screen, press **▲▼◀▶**.
 - The Origin Setup screen appears.
- 2** Press **▲▼◀▶** to move the origin to the desired position.
 - The carriage moves left and right and feeds the medium.
- 3** Press the **[ENTER]** key.
 - The origin is updated.

Starting Printing



- Before starting printing, check to confirm that the remaining amount of cloth wiper is sufficient. Auto maintenance may be performed during printing depending on the ambient temperature in which the machine is located and the [Print Maint.] (☞ P. 178) setting. If the cloth wiper is insufficient, printing will pause without performing auto maintenance. If there is insufficient cloth wiper remaining, replace with a new cloth wiper. (☞ "Cloth Wiper Replacement"(P. 219))

1 Send the RIP data from the PC.

- ☞ "Preparing RIP data"(P. 97)



- If the message "Attention20A Driver version" appears, install the latest Mimaki driver. <https://mimaki.com/download/inkjet.html>

2 Start printing.

- Printing starts once RIP data is received.

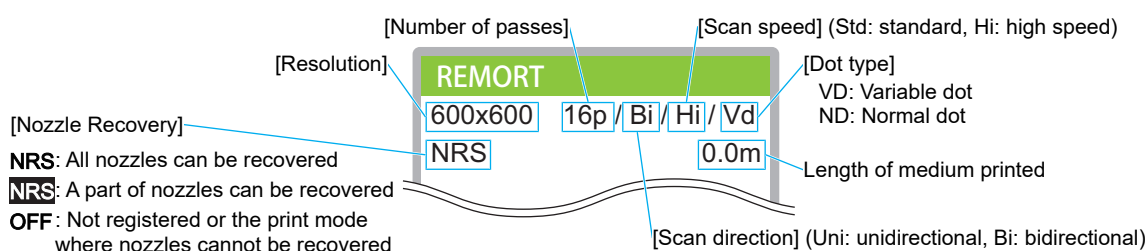

- Print speeds may differ for the same image data, depending on the width of the medium loaded, print origin position, and resolution.
- If an error occurs, the machine switches to LOCAL mode once printing is completed. Further printing is not possible.
- The ink used in this machine is warmed before printing. Printing is disabled while the ink is warmed.

Pausing Printing

1 Press [LOCAL] while printing is in progress.

- Printing is paused.
- If data is being sent from a PC, data transmission is paused at the PC.

2 Press [REMOTE].

- Printing resumes.



- No other functions can be used when printing is paused.

Stopping Printing (Data Clear)

- 1 On the LOCAL mode screen, select [DATA CLEAR].

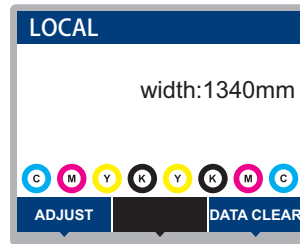

- 2 Press the [ENTER] key to clear the received data.
 - The receive buffer is cleared.

2.13 Cutting the media

- 1** On the LOCAL mode screen, press ▲▼◀▶.
 - The Origin Setup screen appears.
- 2** Press ▲▼ to feed the media to the position required for cutting.
- 3** Select [CUT].
- 4** Select a cutting method.
 - [Horizontal Cut]: The media edge is cut straight.
 - [Horizontal + V Cut]: The media is cut straight and then cut into a V shape.  "V-shaped Cutting"(P. 103)
- 5** Press the [ENTER] key.
 - The media is cut.

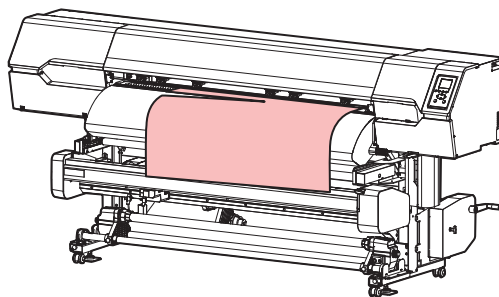

- Pressing the [FUNC2] key while the [Horizontal + V Cut] run screen is displayed creates a tape while simultaneously cutting the media. This can be used to tape the media to the paper core (only for self-adhesive media).



When the machine is not in use, raise the clamp lever to separate the pinch rollers from the grit rollers.

- Leaving the pinch rollers lowered may cause them to become deformed and prevent media from being fed correctly.
- Leaving media loaded will subject it to force from the pinch rollers, which may leave pinch roller marks on it.

V-shaped Cutting

The media edge is cut into a V shape. As only one point of the media is fixed to the paper core with adhesive tape, the media can be wrapped around the paper core with uniform tension.  "Loading the Roll Media"(P. 76)

● Conditions where V-shaped cutting is not available

- The media width detection method is set to "MANUAL".
([MENU] > [Media Setting] > [Media Information] > [Media Width] > [Detection Type] P. 175)



Do not use V-shaped cutting in the following cases!

- The remaining roll media amount is low. Otherwise there is a risk of media jamming or the print head nozzle face coming into contact with the media, making prints dirty.
- When using low stiffness media such as tarpaulin. A media jam may occur.
- The clamp at the right media edge is raised. Some portions of the media may be left uncut.



When using hard, thick media (such as PET or illuminated film)

- The cutter blade will become worn more quickly compared to with other media.
- Some portions of the media may be left uncut.

Chapter 3 Cutting



This chapter

CJV

UCJV

Describes cutting procedures and setting methods (CJV/UCJV).

Cutting Process	106	Test Cutting	117
Installing Cutting Tools	108	Cutting the Cutting Data	118
Using the Cutter	108	Changing the Origin	118
Using a Pen.....	112	Starting Cutting	118
Setting the Cutting Conditions.....	116	Stopping Cutting (Data Clear).....	119
		Retracting the Cutter Unit	119

3.1 Cutting Process

1. Turn on the power.

 ["Turning On the Power"\(P. 37\)](#)

2. Connect this machine to the PC on which the cutting software is installed.

 ["Using a USB Cable"\(P. 41\)](#)

 ["Using a LAN Cable"\(P. 40\)](#)

3. Adjust the Pinch Roller Positions.

Adjust the pinch roller positions to suit the width of the set media. Adjust the pinch roller positions so that the pinch rollers are positioned above the grit rollers. The pinch rollers at both ends should be aligned to within 10 cm from the left edges and 2 cm from the right edges of the media.  ["Adjust the Pinch Roller Positions."\(P. 63\)](#)

4. Loading the Media

This machine can be used with roll media and leaf media.  ["Loading the Media"\(P. 66\)](#)

5. Adjust the number and pressure of pinch rollers to use.

Set an appropriate pressure for the set media.  ["Setting the Pressure and Number of Pinch Rollers to Use"\(P. 87\)](#)

6. Installing Cutting Tools

This machine can be used with a cutter and a pen (ballpoint pen).  ["Installing Cutting Tools"\(P. 108\)](#)

7. Set the cutting speed and pressure.

Set the cutting speed and pressure to match the type of media and tools in use.  ["Setting the Cutting Conditions"\(P. 116\)](#)

8. Perform test cutting.

Perform a test cut to confirm that the tool conditions are set appropriately.  ["Test Cutting"\(P. 117\)](#)

9. Cutting the Cutting Data

👉 "Cutting the Cutting Data"(P. 118)

10. Cutting the media

👉 "Cutting the media"(P. 102)

3.2 Installing Cutting Tools

This machine can be used with the following tools:

- Cutter (for cutting media)
Used to cut the printed image on media or to cut characters with the cutting sheet. 🖱️ ["Using the Cutter"\(P. 108\)](#)
- Pen (ballpoint pen)
Used to adjust register marks This machine can be used with a ballpoint pen or cartridge refill. 🖱️ ["Using a Pen"\(P. 112\)](#)

Using the Cutter

Installing the Cutter in the Cutter Holder

Be careful to keep the cutter from falling into a gap in this machine. We recommend replacing the cutter on the media so you can easily pick up the cutter blade if it falls.



- Avoid touching the cutter blade. Failure to do so may result in injury.
- Do not shake or swing the cutter holder. Doing so may cause the blade to come off.

1 Remove the cap from the cutter holder.

- Turn in the direction indicated by the arrow in the picture.

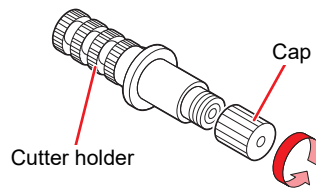

2 Insert the cutter into the cutter holder.

- Use tweezers to insert the cutter.

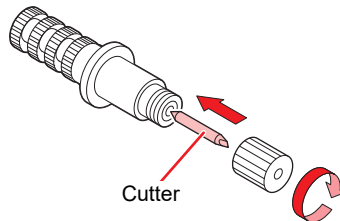

3 Fix the cap by turning in the direction indicated by the arrow in the picture.

Adjusting the Cutting Blade Protrusion Length

Adjust the cutting blade protrusion length (0.2 to 0.5 mm).

- If the base paper is thicker than the label film: $(\text{label film thickness} + \text{base paper thickness})/2$

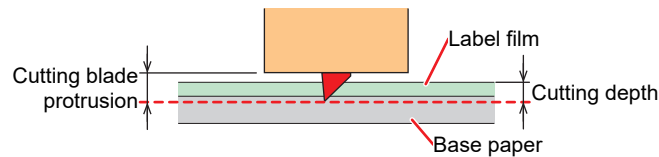

- If the base paper is thinner than the label film: As far as to cut into label film

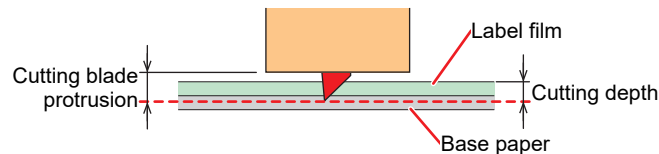

- An option is available to accurately adjust the protrusion amount of the blade tip.
Part number: OPT-C0066 "blade adjuster (for eccentric cutter)"

1 Turn the adjusting knob to adjust the protrusion of the cutting blade.

- Turn the adjusting knob in the direction indicated by the arrow in the picture to have the blade protrude. (0.5 mm per turn)

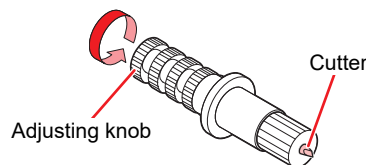

2 Check the cutting performance.

- Adjust the pressure so that it leaves slight marks on the base paper. A cutting blade that protrudes too far may damage the machine. [☞ "Setting the Cutting Conditions"\(P. 116\)](#) [☞ "Test Cutting"\(P. 117\)](#)



- When using the cutter holder included in the delivery, you can adjust the protrusion length while the cutter is attached to the tool holder. (0.5 mm per turn of the adjusting knob)

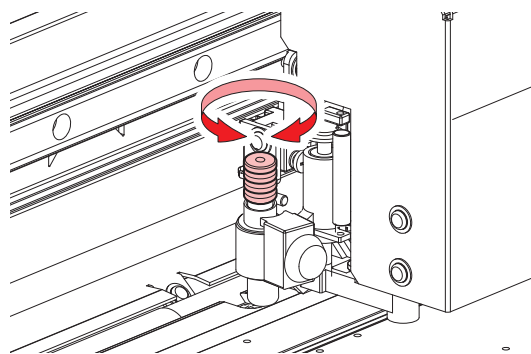

Installing the Cutter Holder

- 1** On the LOCAL mode screen, select [MENU] > [Cutting], then press the [ENTER] key.
 - The Cutting menu is displayed.
- 2** Select [Tool Change], then press the [ENTER] key.
- 3** Open the maintenance cover on the left side.



- The cutter unit can be moved manually. Move the carriage slowly to a position allowing easy access while working.

- 4** Turn the knob screw and loosen the holder presser.

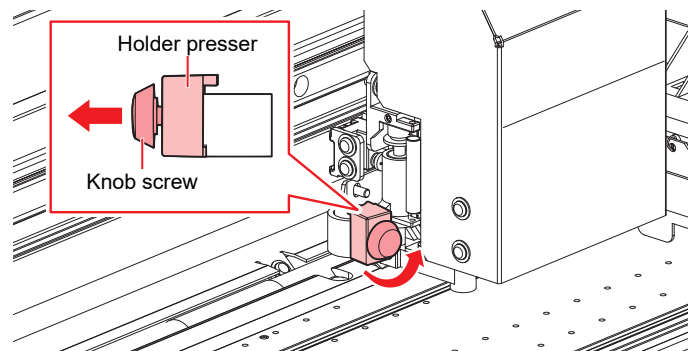

- 5** Insert the cutter holder into the tool holder.

- Push the brim of the cutter holder against the holder presser.

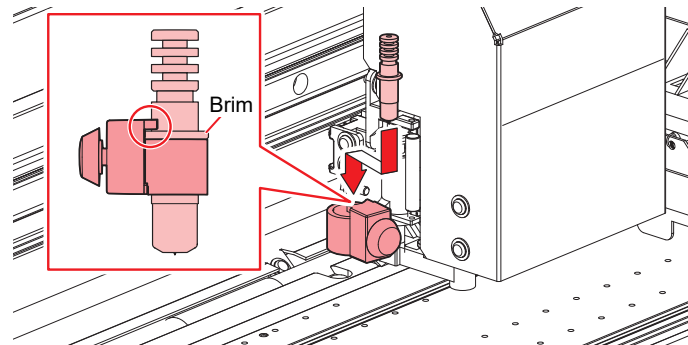

- 6** Secure the cutter holder.

- Turn the knob screw to secure the holder presser. Failure to secure firmly may result in lower quality.

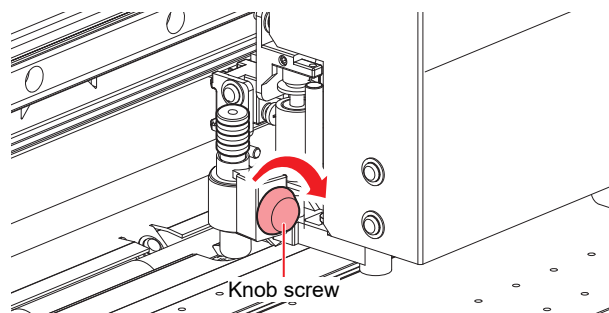

- 7** Close the maintenance cover, then press the [ENTER] key.

Using the Included Cutter Holder (SPA-0001)

1 Loosen the lock nut of the cutter holder and extract the adjusting knob.

- Turn in the direction indicated by the arrow in the picture.

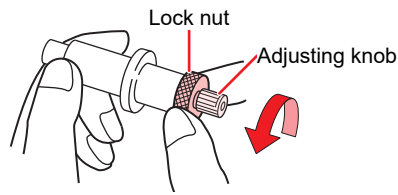

2 Insert the cutter into the adjusting knob.

- Use tweezers to insert the cutter.

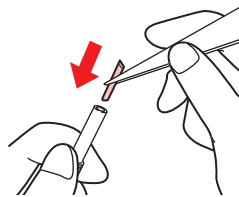

3 Fix the lock nut by turning in the direction indicated by the arrow in the picture.

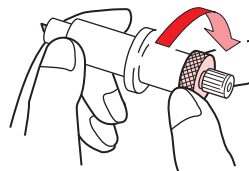

Adjusting the Cutting Blade Protrusion Length

1 Loosen the lock nut of the cutter holder.

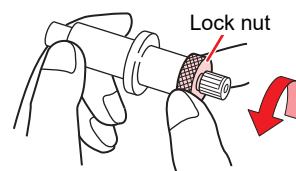

2 Turn the adjusting knob to adjust the protrusion of the cutting blade.



3 Fix the lock nut by turning in the direction indicated by the arrow in the picture.

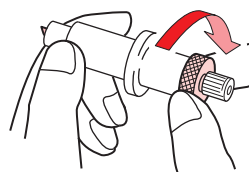

Using a Pen

Installing a Refill Cartridge for a Ballpoint Pen in the Pen Holder

The image quality can vary depending on the type of refill cartridge. Recommended: SXR-5 (Mitsubishi Pencil Co., Ltd.)

1 Remove the cap from the pen holder.

- Turn in the direction indicated by the arrow in the picture.

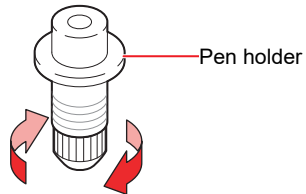

2 Insert a refill cartridge into the pen holder.

- Insert the refill cartridge until it hits the pen holder.

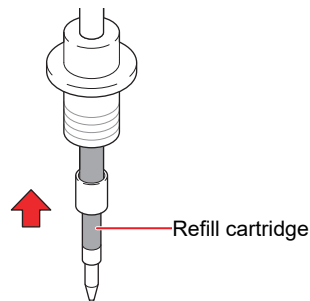

3 Insert the spring into the refill cartridge.

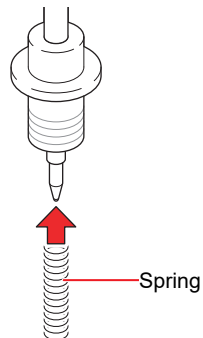

4 Fix the cap by turning in the direction indicated by the arrow in the picture.

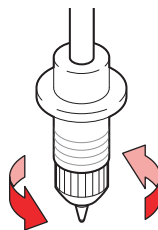

Installing a Ballpoint Pen in the Pen Adapter

Use a ballpoint pen with a diameter of 8 to 9 mm. The ballpoint pen type may affect image quality.
Recommended: K105-GA (Pentel Co., Ltd.)



- Do not use ballpoint pens as shown below. Some types of ballpoint pens may tilt.



Pens with shafts that change thickness midway

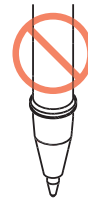

Pens with protrusions or bumps on the shaft

1 Put the cap on the pen adapter.

- The cap is used to adjust the height of the pen nib.

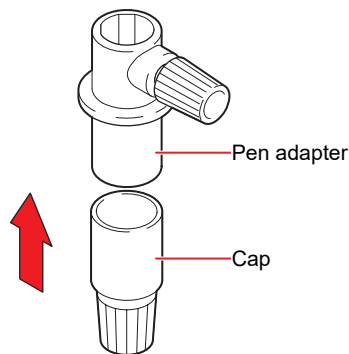

2 Insert the ballpoint pen into the pen adapter.

- Insert the pen nib until it hits the cap.

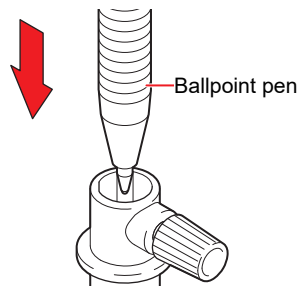

3 Fix the pen nib by turning the knob screw in the direction indicated by the arrow in the picture.

- Be careful to avoid overtightening the knob screw. Disregarding this precaution may damage or break the ballpoint pen.

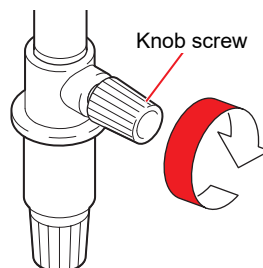

4 Remove the cap.

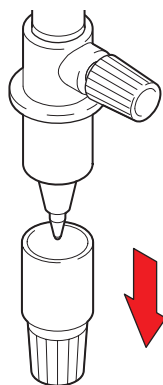

Installing a Pen

1 On the LOCAL mode screen, select [MENU] > [Cutting], then press the [ENTER] key.

- The Cutting menu is displayed.

2 Select [Tool Change], then press the [ENTER] key.

3 Open the maintenance cover on the left side.



- The cutter unit can be moved manually. Move the carriage slowly to a position allowing easy access while working.

4 Turn the knob screw and loosen the holder presser.

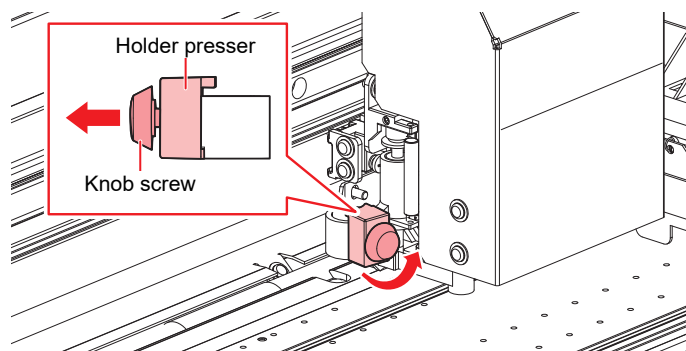

5 Insert the pen holder or pen adapter into the tool holder.

- Push the brim of the pen holder or pen adapter against the holder presser.

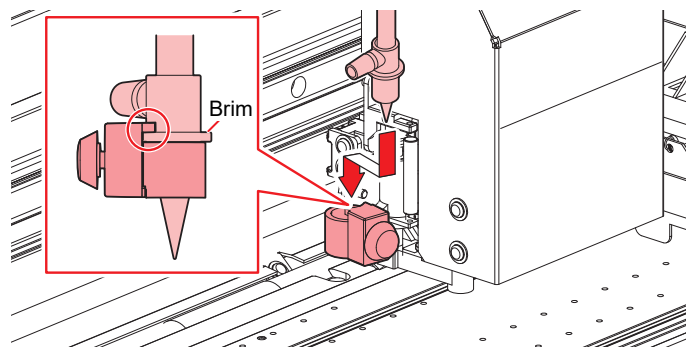

6 Secure the pen holder or pen adapter.

- Turn the knob screw to secure the holder presser. Failure to secure firmly may result in lower quality.

7 Close the maintenance cover, then press the [ENTER] key.

3.3 Setting the Cutting Conditions

You can set the cutting speed and pressure to match the type of media and tools in use.

1 On the LOCAL mode screen, select [TOOL].

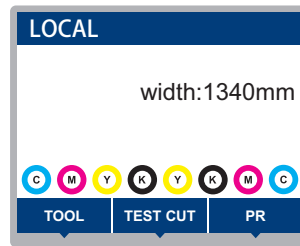

2 Set the conditions.

- The following items can be configured:
- The settings are retained even when the power is turned off.

Item	Setting	Overview
TOOL	CUT1 to 7/ PEN	<ul style="list-style-type: none"> • Press the key repeatedly to change the tool condition in the sequence shown below.
Speed	1 to 30 cm/s	<ul style="list-style-type: none"> • Sets the speed for cutting or pen writing.
Pressure	TOOL: 10 to 450 g PEN: 10 to 150 g	<ul style="list-style-type: none"> • Sets the pressure for cutting or pen writing. • This setting is also required for half cuts.
Offset ^{*1}	0.00 to 2.50 mm	<ul style="list-style-type: none"> • Sets the length from the center of the cutter holder to the cutting blade.
Half Cut ^{*1}	ON/OFF	<ul style="list-style-type: none"> • Cuts across a dotted line without cutting out the base paper. <ul style="list-style-type: none"> • If Half Cut is set to "ON", the three items listed below are displayed: Set the following three items and pressure in the Cutting Conditions menu:
Half Cut Pressure	0 to 300 g	<ul style="list-style-type: none"> • Sets the pressure for the uncut portion.
H-Leng	0.1 to 5.0 mm	<ul style="list-style-type: none"> • Sets the uncut length.
C-Leng	5 to 150 mm	<ul style="list-style-type: none"> • Sets the cut length.

*1. This cannot be set when PEN is selected.

3.4 Test Cutting

Execute test cutting to confirm that the tool conditions are set appropriately.

Increase pressure as the cutter blade grows dull with wear. This is only a temporary measure. We recommend replacing the cutter blade to maintain cutting quality.

- 1 On the LOCAL mode screen, select [TEST CUT].

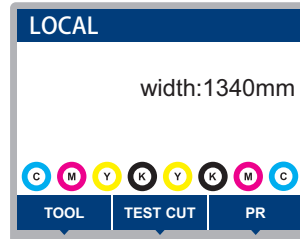

- 2 Select [Test Cut], then press the [ENTER] key.

- Test cutting starts.

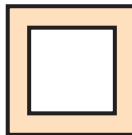





- Check the test cut results, and change the cutting conditions accordingly.

Symptom	Cause	Solution
An uncut section was identified.	<ul style="list-style-type: none"> • Because the speed is too high, the cutting blade passed over the media. 	<ul style="list-style-type: none"> • Reduce the [Speed]. "Setting the Cutting Conditions"(P. 116) • Tighten the knob on the tool holder. "Installing the Cutter Holder"(P. 110)
The base paper of the media is cut.	<ul style="list-style-type: none"> • The pressure is excessive. • The cutting blade protrudes too far. 	<ul style="list-style-type: none"> • Reduce the [Pressure]. "Setting the Cutting Conditions"(P. 116) • Reduce the protrusion of the cutting blade. "Adjusting the Cutting Blade Protrusion Length"(P. 109)
The corners are rounded.	<ul style="list-style-type: none"> • The length from the center of the cutter holder to the cutting blade is not set correctly. 	<ul style="list-style-type: none"> • Adjust the [Offset] value according to the cutter used. "Setting the Cutting Conditions"(P. 116)
The corners are turned up.	Two or more of the following apply: <ul style="list-style-type: none"> • The cutting blade protrudes too far. • The pressure is excessive. • The [MENU] > [Cutting] > [Setup Sub Menu] > [Adj-prs Offset] value is large. 	<ul style="list-style-type: none"> • Reduce the protrusion of the cutting blade. "Adjusting the Cutting Blade Protrusion Length"(P. 109) • Reduce the [Pressure]. "Setting the Cutting Conditions"(P. 116) • Reduce the [Adj-prs Offset] value. "Cutting Menu"(P. 188)

3.5 Cutting the Cutting Data

Check beforehand







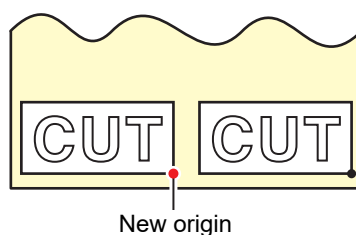

- Was the head gap adjusted?  "Adjusting Print Head Height"(P. 61)
- Were the pinch roller positions adjusted?  "Adjust the Pinch Roller Positions."(P. 63)
- Is media loaded?  "Loading the Media"(P. 66)
- Are the pinch rollers configured?  "Setting the Pressure and Number of Pinch Rollers to Use"(P. 87)

Changing the Origin

You can change the cutting start position. Use the LED pointer to set the origin. The origin set here will be the origin of the cutting software you are using.

When cutting the same data again, change the origin. If not, cutting starts at the same position.



- 1 On the LOCAL mode screen, press    .**
 - The Origin Setup screen appears.
- 2 Press     to move the origin to the desired position.**
 - The carriage moves left and right and feeds the medium.
- 3 Press the [ENTER] key.**
 - The origin is updated.
 - The set tool conditions are displayed on the display.

Starting Cutting

- 1 Press [REMOTE].**
 - The machine switches to REMOTE mode and is ready for cutting.
- 2 Send the cutting data from the PC.**



- For more information, refer to the operation manual of the cutting software you are using.

- 3 Cutting starts.**
 - Cutting starts once the cutting data is received.
 - The remaining amount of data is displayed on the display.



- If the media moves out of place during cutting, immediately turn off the power. Continuing to cut while the media is not in place may damage the machine.

Pausing Cutting

- 1 Press [LOCAL] while cutting is in progress.
 - Cutting is paused.
 - If data is being sent from a PC, data transmission is paused at the PC.

- 2 Press [REMOTE].

- Cutting resumes.



- No other functions can be executed while printing is paused.

Stopping Cutting (Data Clear)

- 1 On the LOCAL mode screen, select [DATA CLEAR].

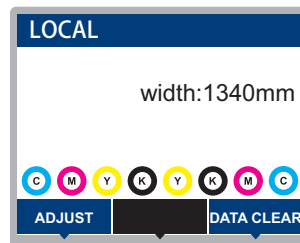

- 2 Press the [ENTER] key to clear the received data.

- The receive buffer is not cleared.

Retracting the Cutter Unit

When cutting or printing-with-a-pen is completed, the cutter unit is positioned on the platen. To check the cutting result or to set new media, retract the cutter unit from the platen.

- 1 On the LOCAL mode screen, select [TEST CUT].

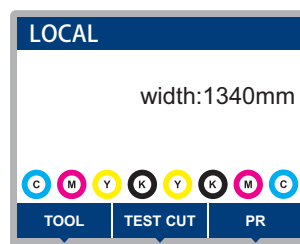

- 2 Select [Cut Head Move/Retract], then press the [ENTER] key.

- If the cutter unit is not connected to the carriage, it moves to the station to connect to the carriage.



- If the cutter unit is connected to the carriage, detach the carriage and move it to the maintenance space on the left side.

Chapter 4 Cutting Data with Register Marks



This chapter

CJV
UCJV).

UCJV

Describes the register mark creation conditions and basic information (CJV/

Process for Cutting Data with Register Marks	122	Setting Mark Detection Conditions	130
Creating Register Marks	124	Detecting the Position of the Register Mark Origin	131
Register Marks	124	ID Cut Process	132
Register Mark Size	125	When using the XY slitter	133
Spacing Between Register Marks	126		
Reading Range of Register Marks	127		
No-Plotting Areas Around Register Marks	128		
Combined Operations of Printing and Cutting	129		

4.1 Process for Cutting Data with Register Marks

1. Create data with register marks.

 ["Creating Register Marks"\(P. 124\)](#)

This machine can detect the following three types of register marks:

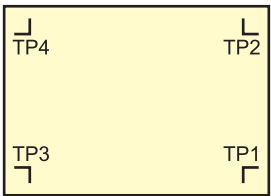
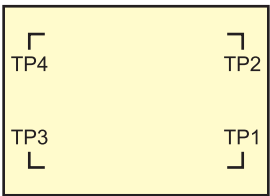
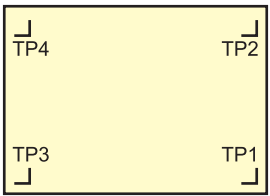
Type 1	Type 2	Zero margin register mark
		

2. Print printing data with register marks.

 ["Print Process"\(P. 58\)](#)

3. Prepare for cutting.

 ["Cutting Process"\(P. 106\)](#) (Steps 4 to 8)

4. Register the information for the printed register marks.

 ["Setting Mark Detection Conditions"\(P. 130\)](#)

5. Detect the register mark origin.

 ["Detecting the Position of the Register Mark Origin"\(P. 131\)](#)

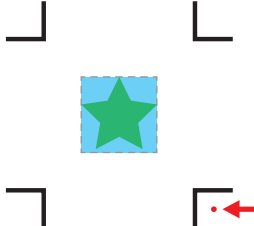
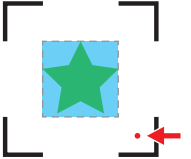
(Mark shape) Type 1	(Mark shape) Type 2
	

6. Cut the data.

👉 "Cutting the Cutting Data"(P. 118)

7. Cutting the media

👉 "Cutting the media"(P. 102)

4.2 Creating Register Marks

Printing image data with "register marks" can increase cutting accuracy and quality. There are some limitations to register marks. Read the following thoroughly before creating register marks.



- Trimming register marks cannot be used with the machine.

Register Marks

The following three types of register marks can be used with this machine:

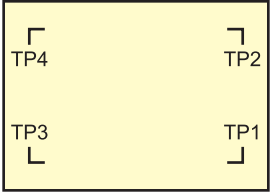
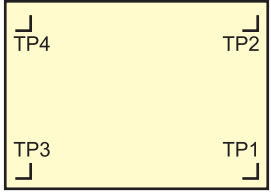
Type 1	Type 2	Zero margin register mark
		



- Use mark 4 (TP4) to perform trapezoidal corrections. Mark 4 can be skipped, but doing so will reduce cutting accuracy.
 Trapezoidal correction: Corrects the difference between the right and left feed amount of the media.

● How cutting accuracy varies by speed

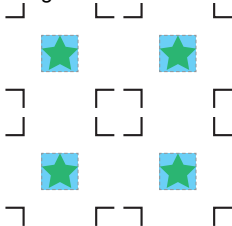
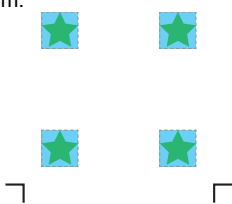
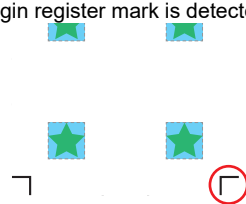
Accuracy	Speed	Register Mark Layout	Detection Type
Higher ↑	Slower ↑	Register marks are arranged at the four corners of each item of image data. 	All register marks are detected.
↓ Lower	↓ Faster	Register marks are arranged at the four corners of the image data as a whole and at positions between them. 	All register marks are detected (4 marks).
			Only the origin register mark is detected (1 mark).
		No register marks	No register marks

Media and Register Mark Color

We recommend using white media and black register marks. The machine may fail to detect register marks in other colors.

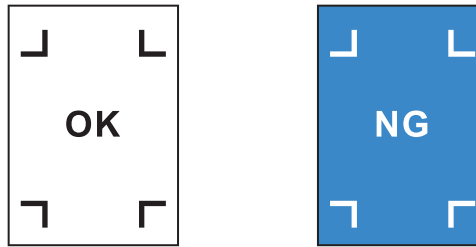

Blurred Register Marks

Ensure that printed register marks are not blurred. If the register marks are blurred, the mark origins may be incorrectly identified, or the machine may fail to detect the register marks.



Register Mark Size

The recommended register mark size (A) is within the range of A4 size (210 mm × 297 mm) to A3 size (297 mm × 420 mm). If the dimensions exceed A3, the machine may fail to detect register marks due to media feeding problems (e.g., media meandering).

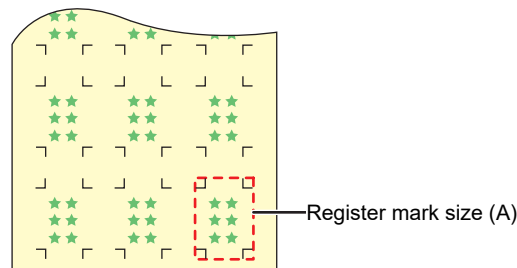

Standards for Register Mark Length and Line Width

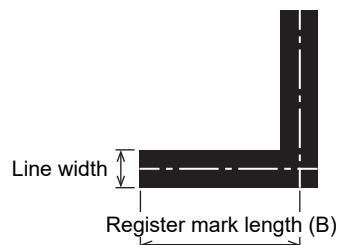

The recommended register mark length and line width are as shown below. The machine may fail to detect register marks that lie outside the recommended range.

Register mark size (A)	Register mark length (B)	Line width
200 mm or less	5 mm	0.5 mm
201 to 500 mm	8 mm	

Register mark size (A)	Register mark length (B)	Line width
501 to 1,000 mm	15 mm	1.0 mm
1,001 to 2,000 mm	25 mm	
2,001 mm or more	35 mm	

- If the "Fill around the registration marks" function of the RIP software is enabled, the register mark length (B) should be 10 mm or more.

When Printing Register Marks Continuously

The register mark length (B) should be 8 mm or more. The machine may fail to detect register marks less than 8 mm if it reads them continuously.

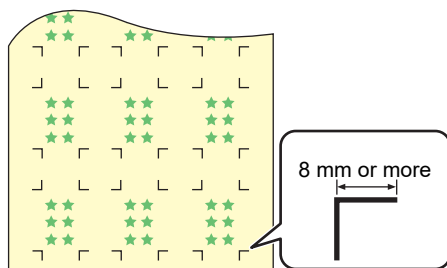

Spacing Between Register Marks

The spacing between register marks (C) is as shown below.

(Mark shape) Type 1	(Mark shape) Type 2
Register mark length (B) x 2 + α, up to 1,000 mm	Register mark length (B) + α, up to 1,000 mm

● Mark Origin Mis-detection Example

- If the spacing between register marks (C) is narrow, as shown in the figure below, the machine may fail to detect them.

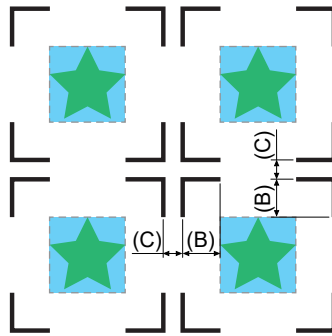

Reading Range of Register Marks

This machine can detect register marks in the range shown below. If the margin is small, the edge of the media may be incorrectly identified as a register mark.

When copying data with MIMAKI RIP software (RasterLink), leave a space of at least 210 mm from the rear edge of the media.

(Mark shape) Type 1	(Mark shape) Type 2
<p>110 (or 210) mm</p> <p>50 to 3,000 mm</p> <p>50 mm or more</p> <p>20 mm or more</p> <p>5 mm or more</p> <p>5 mm or more</p> <p>[Rear]</p> <p>[Front]</p> <p>■ : No-plotting area ■ : Cut area ■ : Media</p>	<p>110 (or 210) mm + (mark length (B)/2) or more</p> <p>Within 3,000 mm</p> <p>50 mm or more</p> <p>20 mm + (mark length (B)/2) or more</p> <p>5 mm or more</p> <p>5 mm or more</p> <p>[Rear]</p> <p>[Front]</p> <p>■ : No-plotting area ■ : Cut area ■ : Media</p>

ID Cut

This machine can detect register marks in the range shown below. If the margin is small, the edge of the media may be incorrectly identified as a register mark.

When copying data with MIMAKI RIP software (RasterLink), leave a space of at least 210 mm from the rear edge of the media.

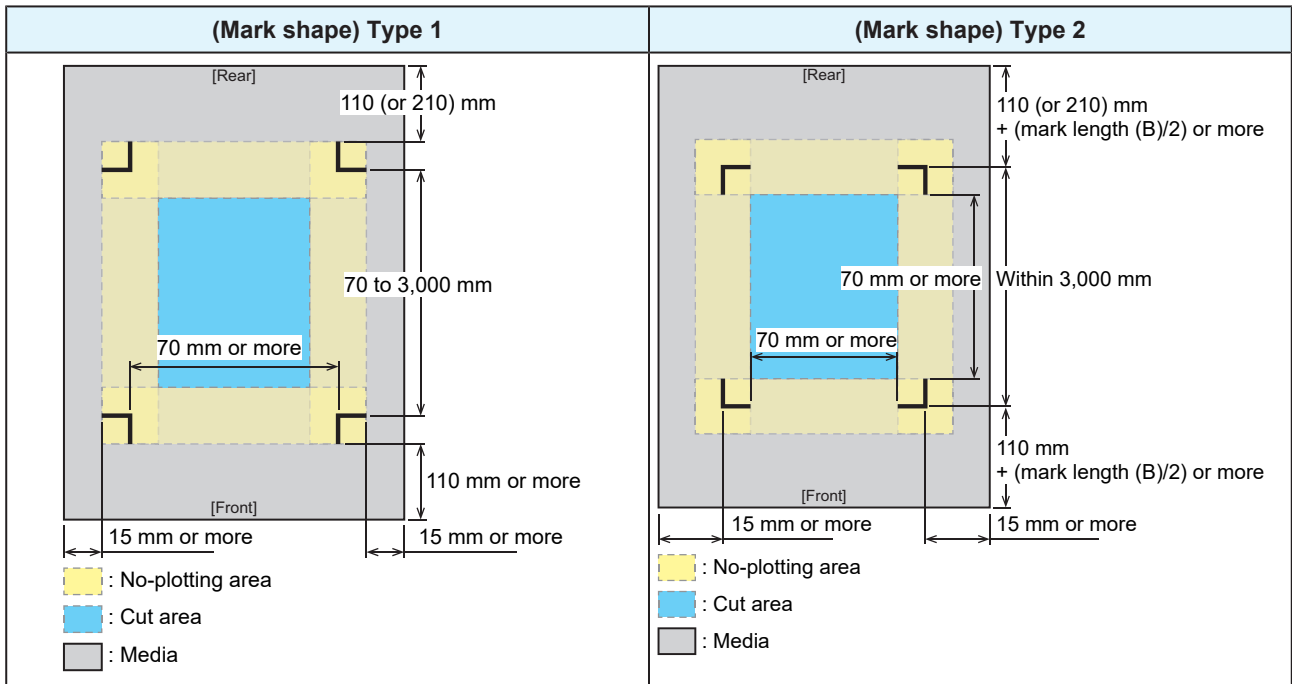

• For more information, refer to the ID Cut Guide. <https://mimaki.com/download/software.html>

No-Plotting Areas Around Register Marks

Do not plot data around register marks. The mark origins may be identified incorrectly, or the machine may fail to detect the register marks.

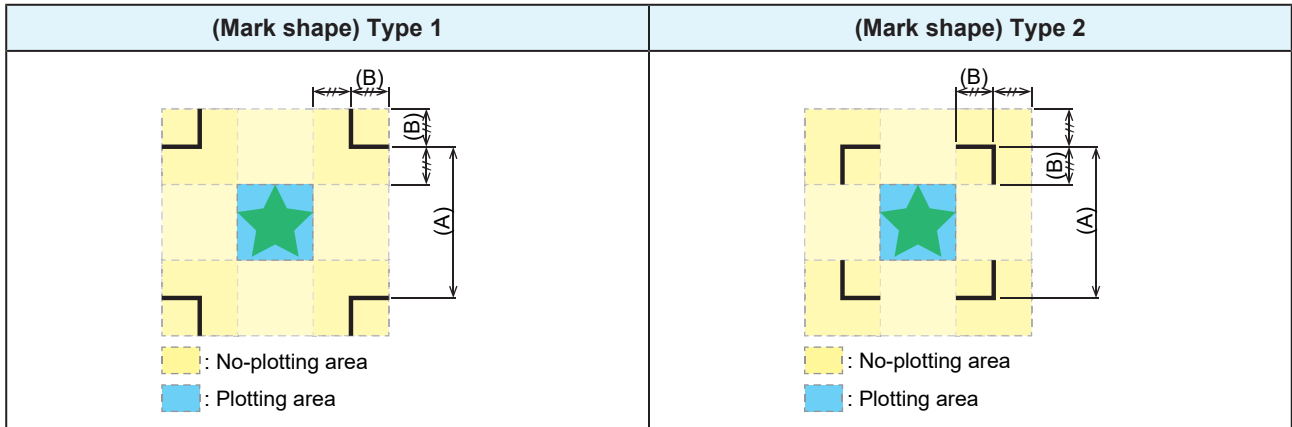

● Mark Origin Mis-detection Example

- If register marks are plotted in the no-plotting area as shown in the figure below, the line may be incorrectly identified as a register mark.

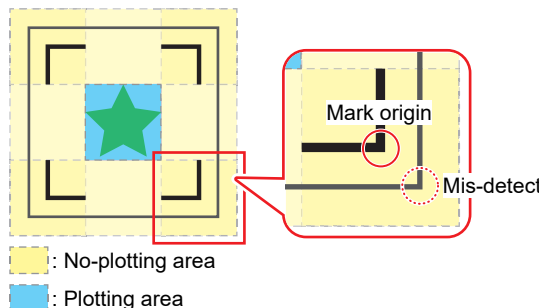

Combined Operations of Printing and Cutting

When printing and cutting with MIMAKI software (RasterLink, FineCut), please note the following:

- The mark size and mark shape settings configured in the machine will be disregarded. Software settings take precedence.
- We recommend printing and cutting using data with register marks. The volume of print data may affect cutting accuracy.
- Although it is possible to print and cut data without register marks using take-up units, doing so may reduce cutting accuracy.

4.3 Setting Mark Detection Conditions

Set the conditions of the printed register marks.

1 On the LOCAL mode screen, select [MENU] > [Cutting], then press the [ENTER] key.

- The Cutting menu is displayed.

2 Select [Mark Detect], then press the [ENTER] key.

- The Mark Detect menu is displayed.



- The Mark Detect menu can also be displayed as follows:

- (1) On the LOCAL mode screen, select [TEST CUT].
 - (2) Select [TP Detect Setup], then press the [ENTER] key.
-

3 Select and set the items.

-  ["Cutting Menu"\(P. 188\)](#)

4.4 Detecting the Position of the Register Mark Origin

- 1 On the LOCAL mode screen, select [TEST CUT].

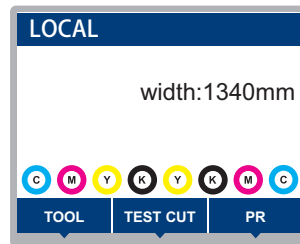

- 2 Select [Mark Detection], then press the [ENTER] key.

- The machine switches to MARK DETECT mode.
- The cutting unit moves over the platen.



- If the machine does not switch to MARK DETECT mode, set the [TEST CUT] > [TP Detect Setup] > [Detect] setting to "ON".

- 3 Press to move the LED pointer to the center of the register mark.

(Mark shape) Type 1	(Mark shape) Type 2

- 4 Press the [ENTER] key.

- Register mark detection starts.

4.5 ID Cut Process

1. Create data with ID Cut.



- For more information, refer to the ID Cut Guide. <https://mimaki.com/download/software.html>

2. Print printing data with ID Cut.

 "Print Process"(P. 58)

3. Prepare for cutting.

 "Cutting Process"(P. 106) (Steps 4 to 8)

4. Register the information for the printed register marks.

 "Setting Mark Detection Conditions"(P. 130)

5. Detect the register mark origin.

 "Detecting the Position of the Register Mark Origin"(P. 131)

6. Cut the data.

 "Cutting the Cutting Data"(P. 118)

7. Cutting the media

 "Cutting the media"(P. 102)

When using the XY slitter

- When using slitting afterwards (☞ "Slitting the Print Media Afterwards"(P. 157)) in combination, set "Offset X" ([MENU] > [Cutting] > [Mark Detect] > [Detect Area] > [Offset X]☞ P. 188) so that this comes after the XY slitter detection mark.

[Offset X]: Set position

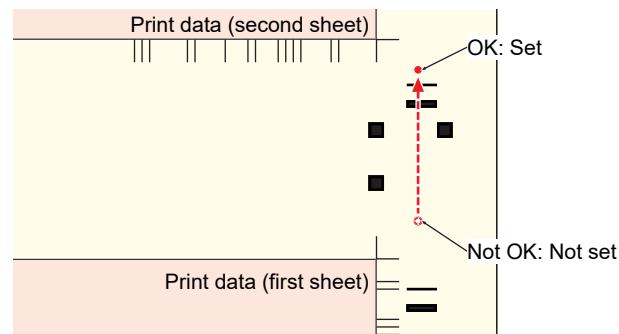

Chapter 5 Using the XY Slitter



This chapter

JV

CJV

UCJV





Describes the procedures for slitting with the XY slitter and RIP setting methods (JV/CJV/UCJV (option)).

XY Slitter	136	Slitting the Print Media Afterwards	157
XY Clamp Lever	137	Disable the XY Slitter	159
X Cutter	138	Setting the Media Width Detection Type to	
Using the Tension Bar	139	AUTO	159
Media Chute	139	Loading the Media	159
Slitting Simultaneously With Printing	143	Printing guide (slit) line	159
Enable the XY Slitter	144	Printing RIP data	159
Loading the Media	144	Enable the XY Slitter	160
Printing guide (slit) line	148	Positioning printed media	160
Mounting the X cutter	151	Detecting slitting marks	161
Printing RIP data	155	Mounting the X cutter and slitting	164
		Troubleshooting	170
		If a Media Jam Occurs in the XY Slitter	170
		If the Y Slit Position is Offset	171

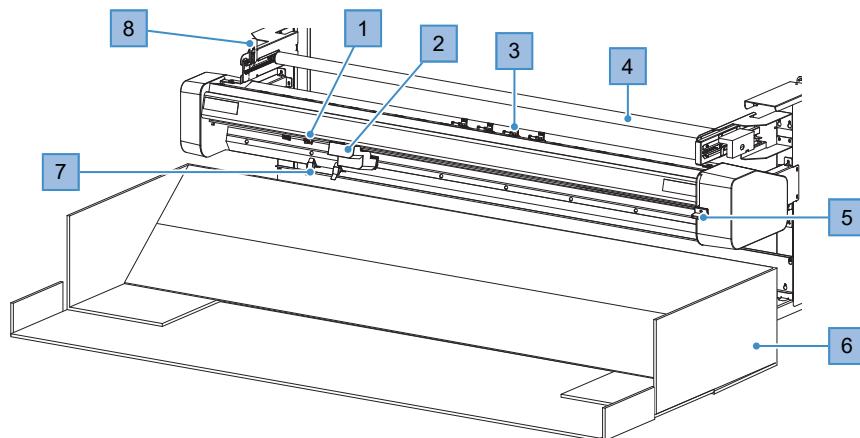
5.1 XY Slitter

 "Specifications (XY Slitter)"(P. 285)



No.	Name	Overview
1	X Cutter	Cutter for cutting the media in the feed direction.  "X Cutter"(P. 138)
2	XY carriage	The XY carriage is made up of the mark sensor for reading slitting marks and the Y cutter for slitting the media in the scan direction.
3	XY clamp	Hold the media. These can be individually unclamped and moved.  "Operating the XY clamps individually"(P. 137)
4	Tension bar	Tensions the media to prevent it sagging.  "Using the Tension Bar"(P. 139)
5	XY Clamp Lever	Raising the clamp lever secures the media. Lowering the clamp lever releases the media. This operation is reverse to that on the main unit.  "XY Clamp Lever"(P. 137)
6	Media Chute	This box holds the media slit by the XY slitter.  "Media Chute"(P. 139)
7	Media guides	These parts guide the slit media into the media chute.
8	stopper	Clamps and unclamps the tension bar.

XY Clamp Lever



- This operation is reverse to that of the clamp lever on the main unit.

● Raising the XY clamp lever

The media is secured (clamped).

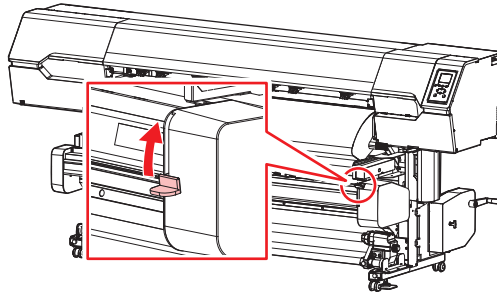

- Do not pull the media when the XY clamp lever is raised (the media is clamped). Doing so may damage the machine.

● Lowering the XY clamp lever

The media is released (unclamped).

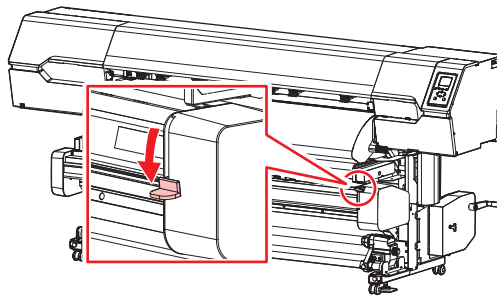

- The XY carriage can be moved by hand when the XY clamp lever is lowered.

Operating the XY clamps individually

The XY clamps can be individually unclamped and clamped. Pushing the XY clamp lever to the rear releases the XY clamp, enabling it to be moved.

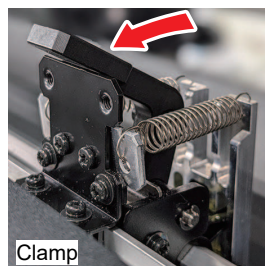

- The XY clamps should be unclamped individually in locations where the media is not present. Note that they cannot be operated using the XY clamp lever if they have been individually unclamped.

X Cutter

● Method for securing the X cutter

Raise the X cutter lever to secure the cutter.

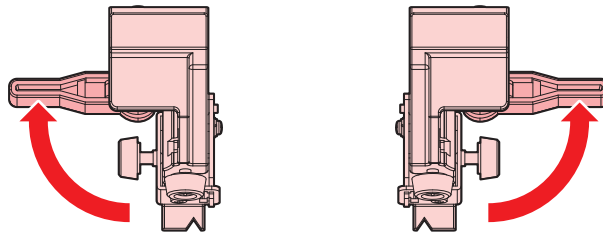

● Method for mounting the X cutter

Insert the X cutter groove onto the L-shaped slide rail.

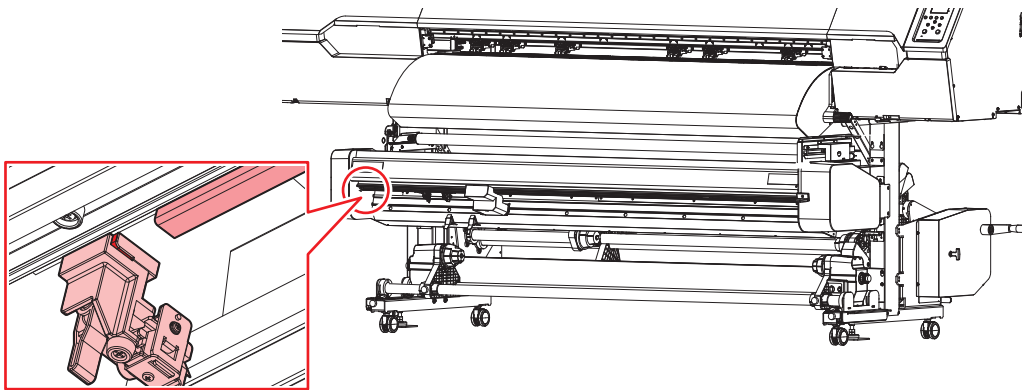

● Unused X cutter

Important!

- Slide out the unused X cutter, or move it away from the media and secure it by raising the lever. If you start printing with the lever being lowered (unsecured), the X cutter may hit the XY carriage and result in damage.

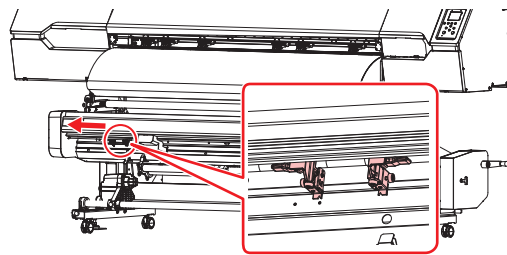

Using the Tension Bar

To move the XY slitter tension bar, push down on it while moving.

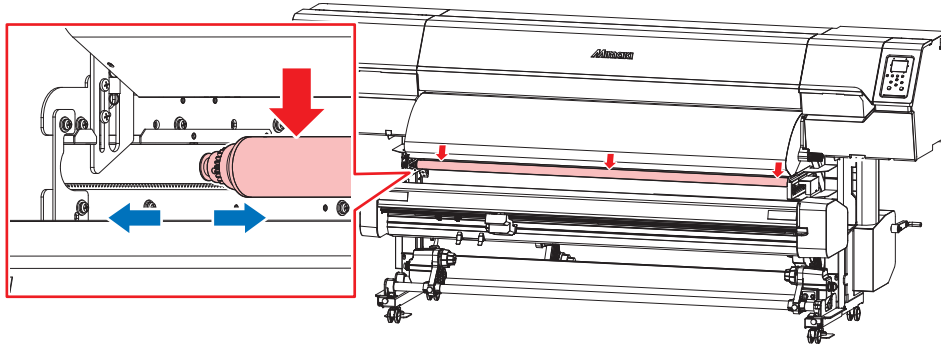

Media Chute

This box holds the media slit by the XY slitter.

The box provided with the machine can be used as a media chute. [☞ "Using the Media Chute"\(P. 139\)](#)

Important!

- Not using the media chute may lead to inconsistent discharge, resulting in media jamming and affecting the slitting quality. Either use the box provided with the machine or provide a separate media chute.
- [Line Space] should be set when printing continuously. [☞ "When set to \[Normal\] or \[Line Space\]"\(P. 140\)](#)

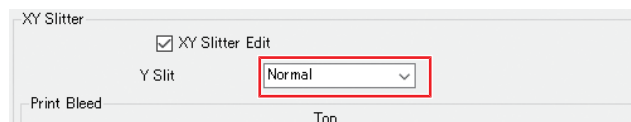

- Be aware of the volume of media inside the media chute when using the XY slitter for the first time. Print quality may be reduced if the media chute is full.
- There is a risk of media printed surfaces sticking together if the media is folded in half or if the media surfaces are left in contact with each other. Take great care to ensure that media sheets are not stuck together when using the XY slitter for the first time.
- Media should be removed from inside the media chute as often as possible.



- The storage capacity varies depending on the media material and cut size.

Using the Media Chute

The way in which the media chute is used will vary depending on the RasterLink [Y Slit] setting.

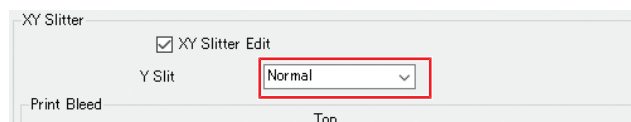

When set to [Normal] or [Line Space]

- 1 Place the media chute under the XY slitter.

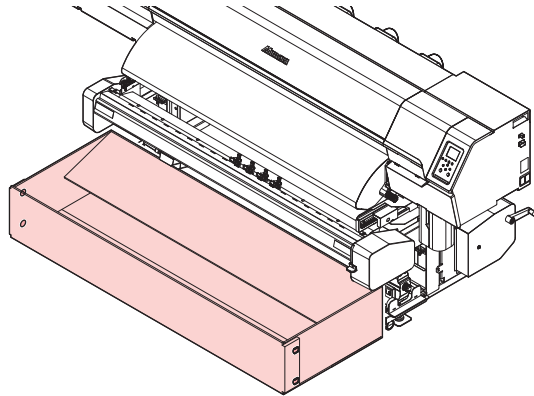

- 2 Push the media chute front forward.

- Remove the screws at the front of both sides. Be careful not to lose the screws.

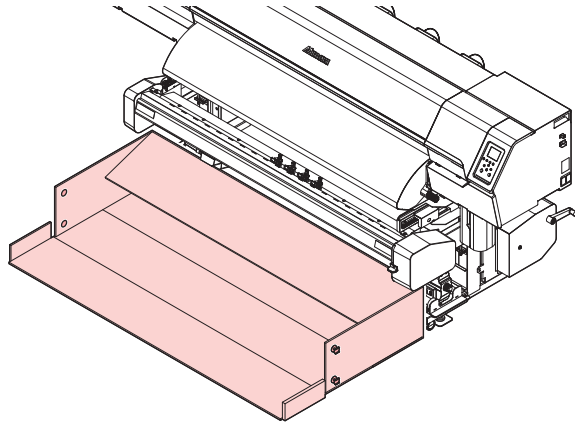

- Place so that the blank pieces cut off are ejected to the media chute.
 - Use the media support.
-



Try the following if the print length is 600 mm or less and the prints do not fall consistently into the media chute.

- Pattern 1: Close the front of the media chute and secure it with screws. (Use the media support.)

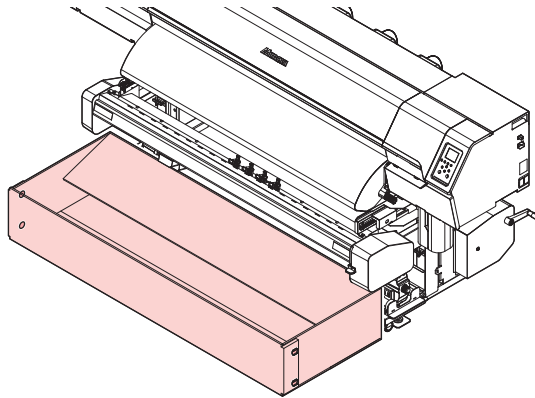

- Pattern 2: If problems occur when arranged as described above, turn the media chute around so that the front is at the rear. (Do not use the media support.)

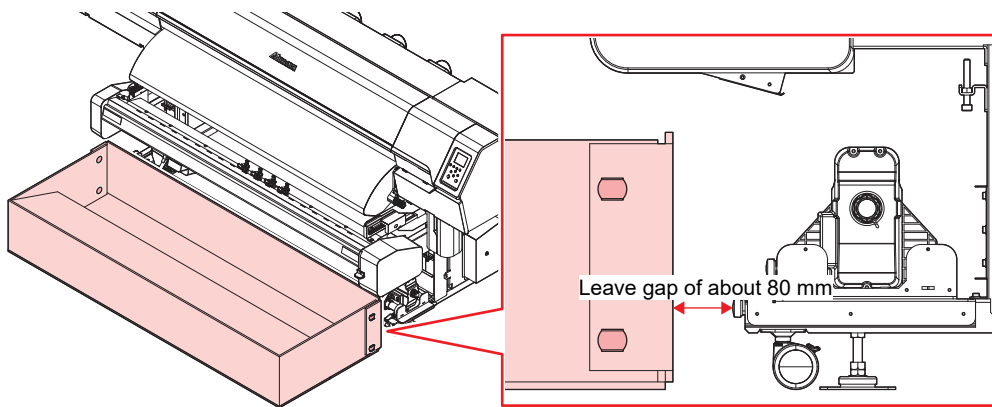

If the prints make contact with the media chute, move the media chute closer to the machine.

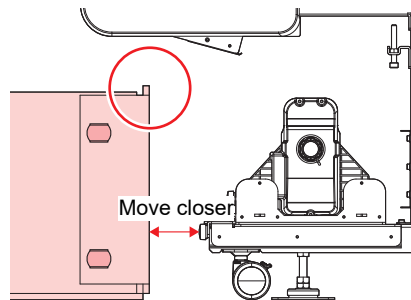

When set to [Nothing]

- 1 Place the media chute under the XY slitter.

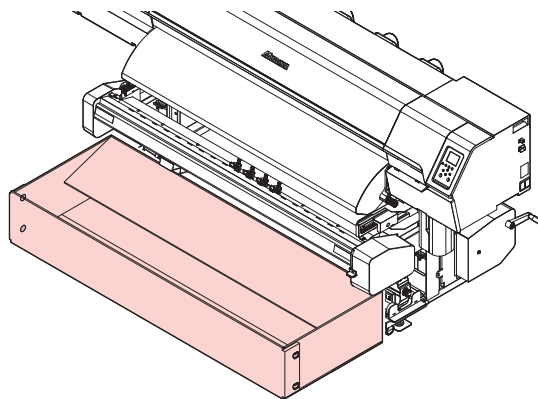

- Place so that the blank pieces cut off are ejected to the media chute.
 - Use the media support.
-

5.2 Slitting Simultaneously With Printing



- Slitting cannot be performed at the same time as "Print&Cut" or "Cut&Print".

1. Enable the XY Slitter.

["Enable the XY Slitter."\(P. 144\)](#)

2. Loading the Media

Put the media through the XY slitter. ["Loading the Media"\(P. 144\)](#)

3. Printing guide (slit) line

Select "Slit at the same time as printing" in RasterLink. ["Printing guide \(slit\) line"\(P. 148\)](#)

4. Mounting the X cutter

Cut the frame for positioning the media guides. Align the X cutter with the printed guide (slit) line. ["Mounting the X cutter"\(P. 151\)](#)

5. Printing RIP data

RIP data is slit at the point it is printed. ["Printing RIP data"\(P. 155\)](#)

Enable the XY Slitter.

- 1 On the LOCAL mode screen, select [MENU] > [Function Setting], then press the [ENTER] key.
 - The Function Setting menu is displayed.
- 2 Select [Finisher] > [XY Slitter], then press the [ENTER] key.



Loading the Media

● Media path

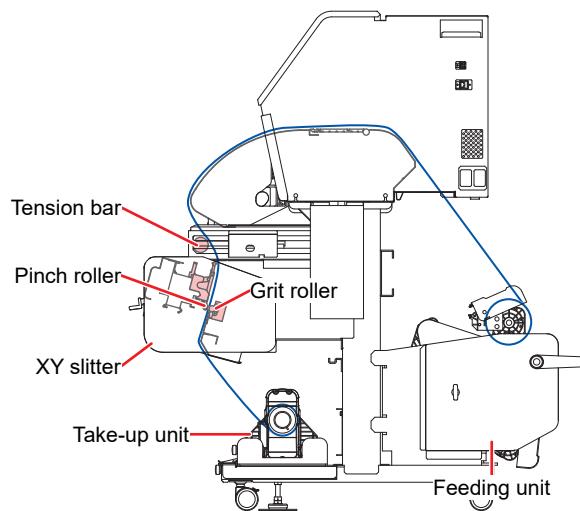

- Adjust the head height before loading media. Moving the carriage after the media has been loaded may result in the print head coming into contact with the media and being damaged.



- For instructions on how to load media, refer to ["Loading the Roll Media"\(P. 76\)](#) (Steps 1 to 22).
- The torque limiter should ideally be set to "Mid". ["Adjusting the Torque Limiter"\(P. 68\)](#)

- 1 Detach the stopper and move the tension bar to the rear.

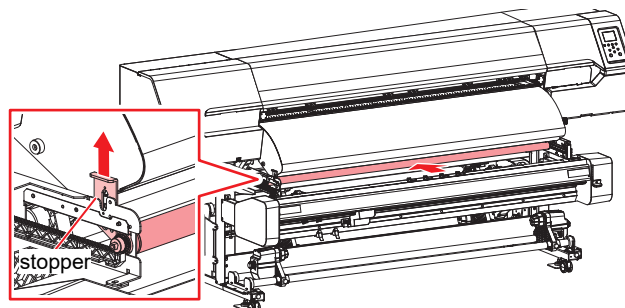

2 Lower the XY clamp lever.

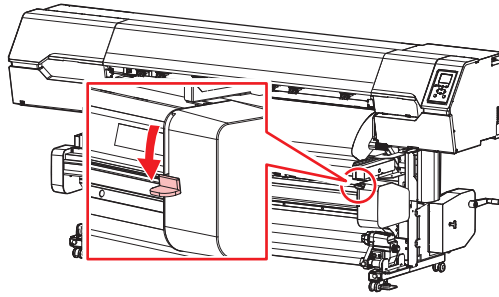

- The XY carriage can be moved by hand when the XY clamp lever is lowered.

3 Move the X cutter to the side and raise the X cutter lever to secure it.

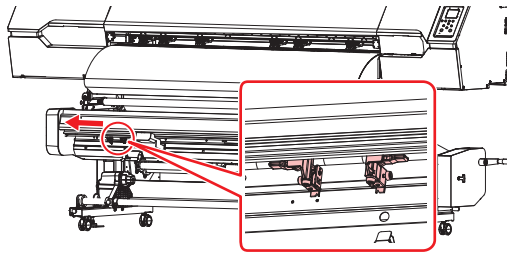

- Avoid touching the cutter blade. Failure to do so may result in injury.

4 Press to feed the media to a position approximately 300 mm from the bottom face of the front cover, then press the [ENTER] key.

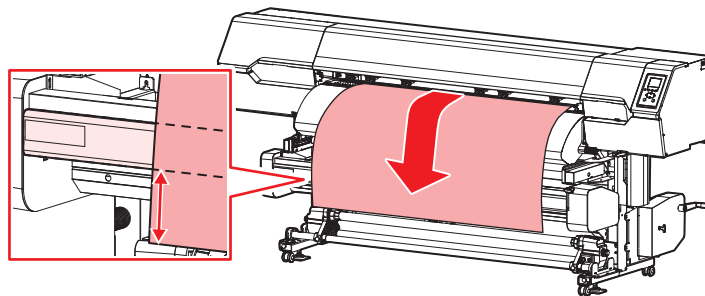

5 Engage the media on to the tension bar and pull it out from the bottom.

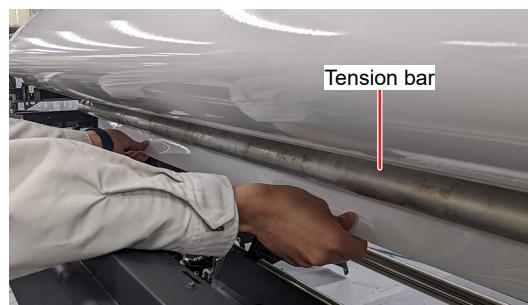

6 Insert the media between the pinch rollers and the grit rollers of the XY slitter.

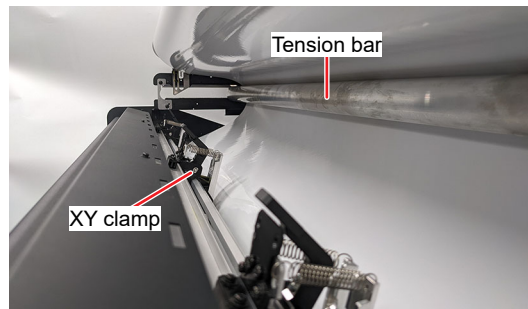

- If it is difficult to insert the media, the XY clamps should be individually unclamped, clamped, then unclamped again.

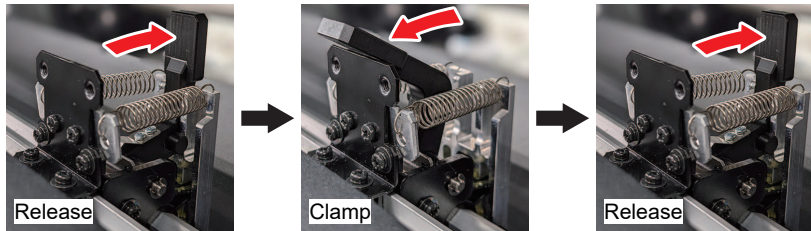

7 Pull the tension bar to the front and secure it.

- This releases any tension from the media.

8 Press to feed the media until it reaches the paper core on the take-up unit, then press the [ENTER] key.

9 Secure the middle of the media to the paper core with adhesive tape.

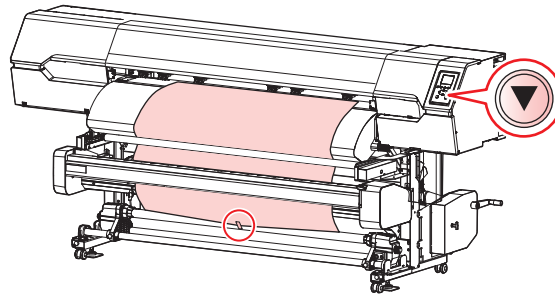

- If the media edge is straight, secure the left and right sides of the media. Pull the lower edge of the media evenly on both the left and right sides, check to confirm that it is free of sagging and creasing, then affix the tape.

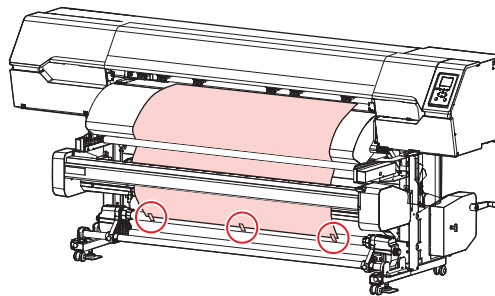

10 Press to wrap the media about one and a half turns around the paper core, then press the [ENTER] key.

11 Move the XY clamps.

- Position the XY clamps on both edges and at the center of the media.
- Align the XY clamps with the mark (square hole) positions.

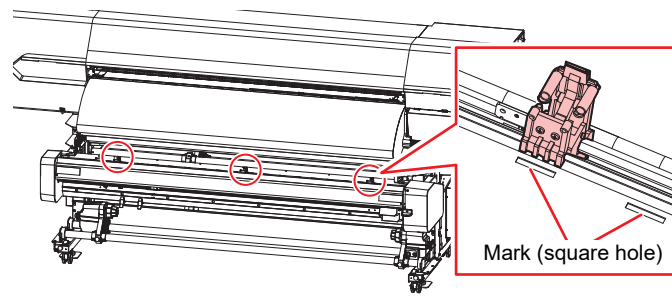

- Position the XY clamps so that the clamp centerlines align with the marks (square holes). The media cannot be transported correctly unless the XY clamp centerlines are aligned with the marks (square holes).

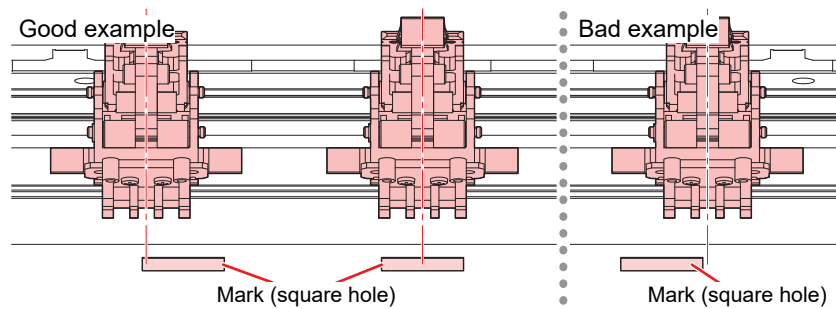

12 Check the XY clamp states.

- XY clamps that are not used: Check that they are unclamped.
- XY clamps that are used: Check that they are clamped.

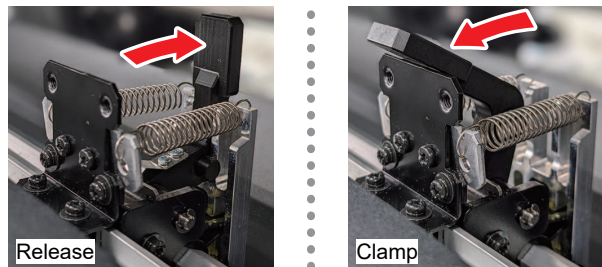

- The XY clamps should be unclamped individually in locations where the media is not present. Note that they cannot be operated using the XY clamp lever if they have been individually unclamped.

13 Raise the XY clamp lever.

- Hold the media.

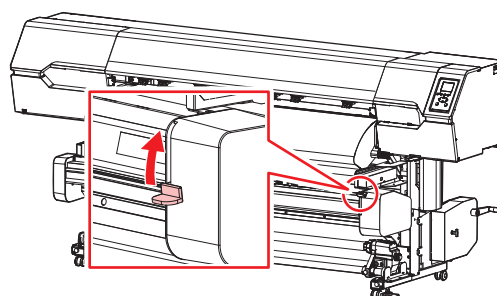



- Do not pull the media when the XY clamp lever is raised (the media is clamped). Doing so may damage the machine.

14 Individually unclamp the clamps in locations where the media is not present (i.e. Clamps that are not used).

-  "Operating the XY clamps individually"(P. 137)

15 Press to decrease the media tension slightly, then press the [ENTER] key.

16 Unlock the tension bar.

- This applies tension to the media.

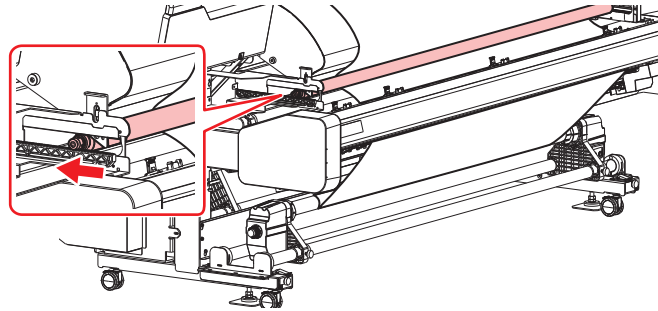

Printing guide (slit) line

The explanation here applies to MIMAKI RIP software (RasterLink).



- The slitting size is 210 mm or more in the Y (scan) direction and 297 mm or more in the X (feed) direction.



- For more information, refer to the RasterLink reference guide. <https://mimaki.com/download/software.html>



- Prepare suitable image data.
- When slitting from the front edge of the media, leave at least 1,000 mm of space from the front edge to the guide (slit) line.

1 Launch RasterLink.

- Click the icon on the PC desktop.



2 Select the image data to print.

- (1) Select [File] > [Open].
- (2) Select the desired image data, then click [Open].
 - If multiple printers are registered, select 330 Series in "Printer Name".

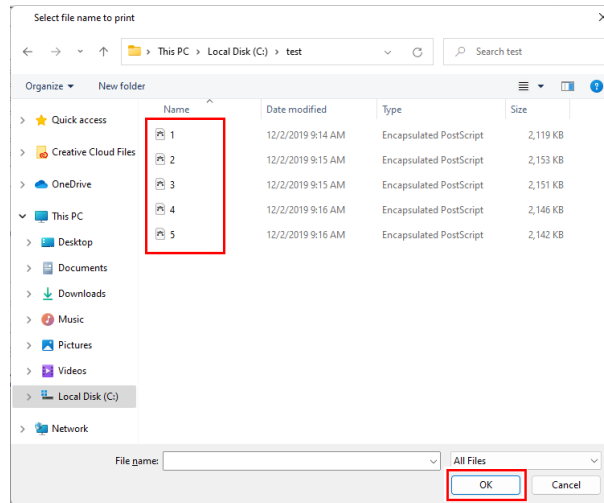

3 Select the image data imported.

- The image data is added in the tab for 330 Series selected in "Printer Name".

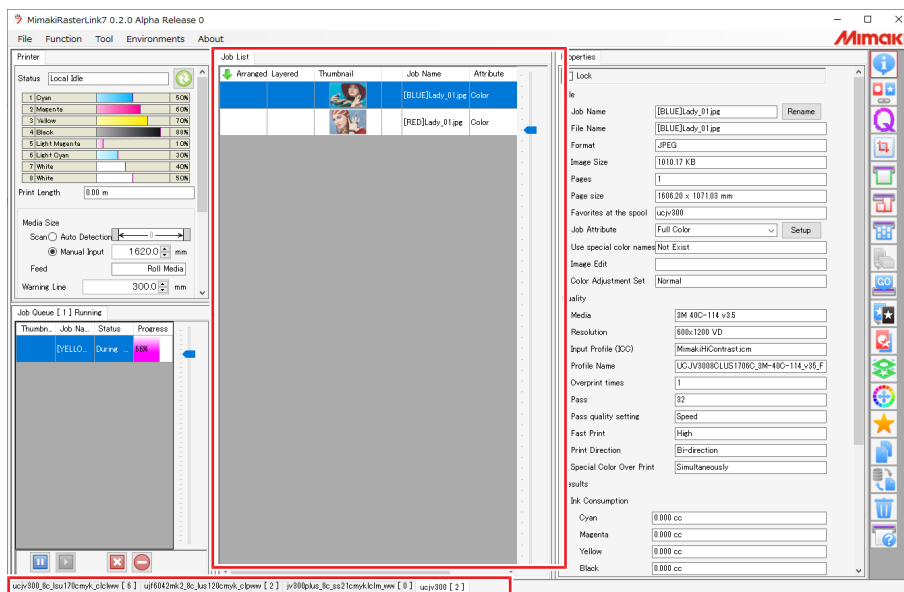

4 Click (General Print) to check the settings and alter as necessary.

- Specify settings like scaling and rotation.



- The XY slitter cannot be used with the following print conditions. Alter the print conditions if you wish to use the XY slitter.

- (1) Resolution: 600 × 600 dpi, Passes: 2 passes

5 Enter the number of prints for [Copy] on the Image Edit tab.

6 Select the [XY Slitter Edit] check box on the Image Edit tab.

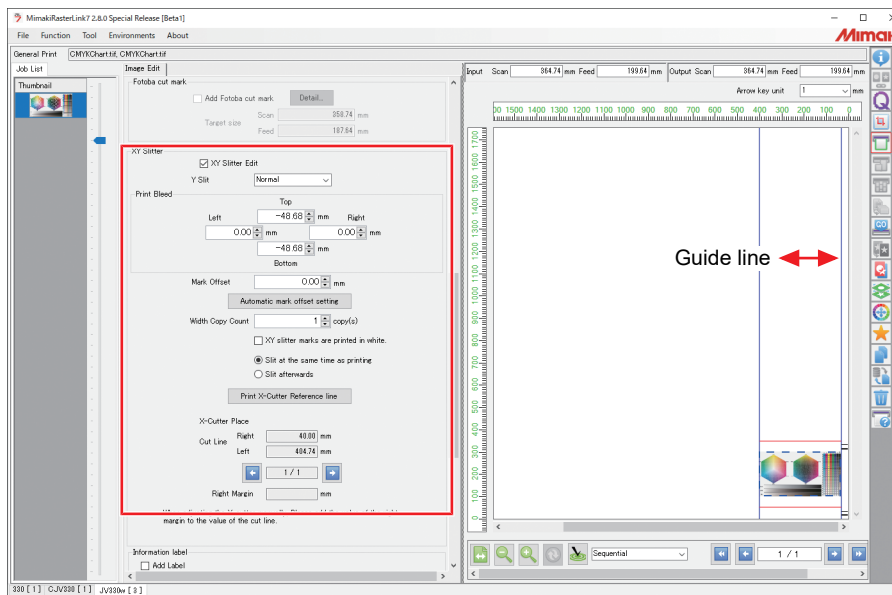

7 Select the slitting method for the Y (scan) direction.

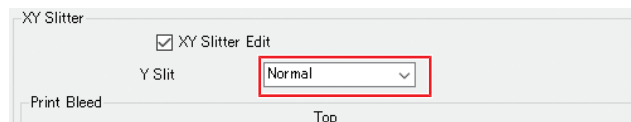

- "None" is used when slitting only in the X (scan) direction.

8 Select the timing for slitting.

- Slit at the same time as printing: To slit simultaneously with printing.
- Slit Afterwards: To slit after printing.

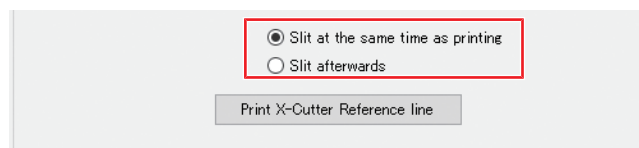

9 Click [Print X-Cutter Reference line].

- Guide (slit) line printing starts.

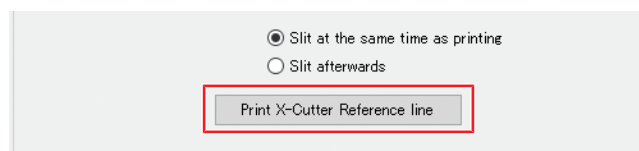

- Do not print any other data after printing the guide (slit) line until the X cutter has been mounted. Otherwise, the X cutter cannot be mounted.

Mounting the X cutter



- Do not touch the X cutter when the XY clamp lever is raised. Otherwise, you may get injured by the moving XY carriage.

1 Press the [ENTER] key.

- The printed guide line is fed to the slitter.

XY slitter usage preparation
Start XY Slitter preparation
[ENT]

2 Lower the XY clamp lever.

Up the clamp lever of XY Slitter

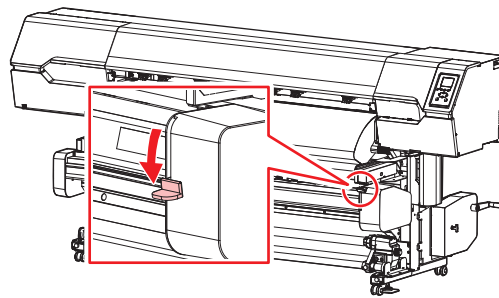

- The XY carriage can be moved by hand when the XY clamp lever is lowered.

3 Move the XY clamps.

- Align the XY clamps with the mark (square hole) positions.

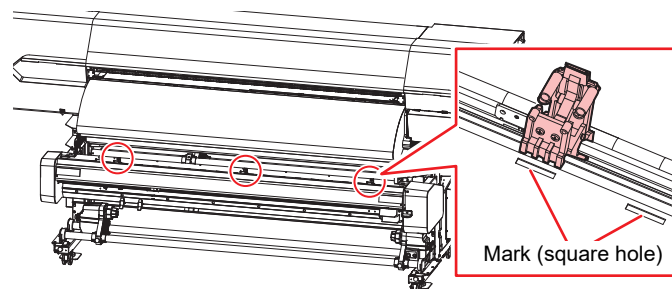

- Position the XY clamps so that the clamp centerlines align with the marks (square holes). The media cannot be transported correctly unless the XY clamp centerlines are aligned with the marks (square holes).

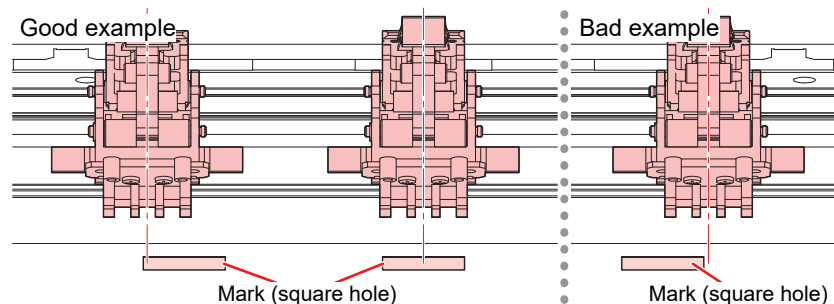

Important! Alter the XY clamp positions according to the RasterLink [Y Slit] setting.

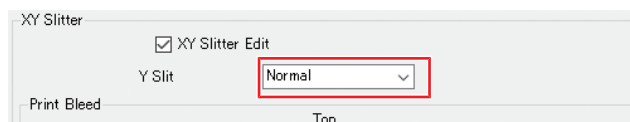

- **With "Normal" or "Line Space" selected:**
Always clamp at both edges of the media.
Do not clamp over the print data area.
Unclamp the XY clamps that are not used.

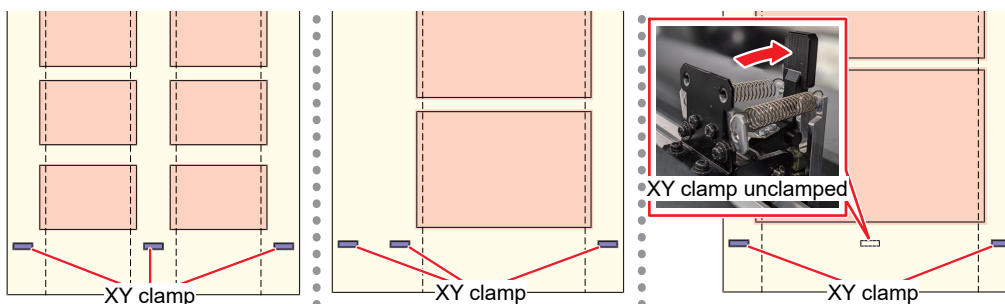

- **With "None" selected:**
Clamp over the print data area (inside the X cutter).
Unclamp the XY clamps that are not used.

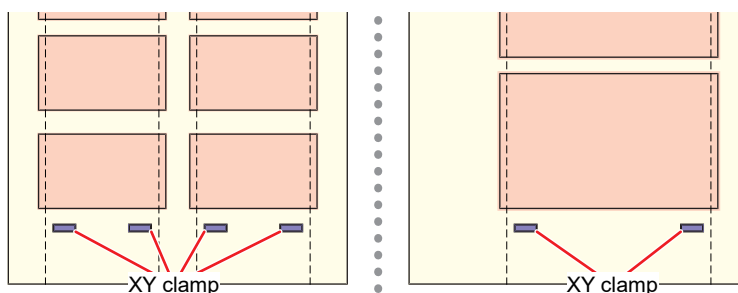

4 Align the groove in the X cutter with the printed guide line, embed the blade in the media, then raise the lever to secure.

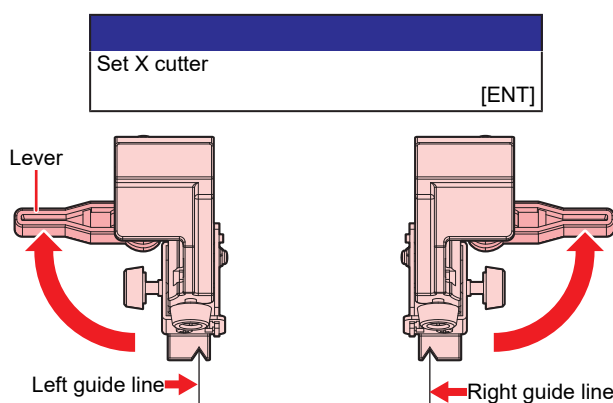

- Avoid touching the cutter blade. Failure to do so may result in injury.



- Slide out the unused X cutter, or move it away from the media and secure it by raising the lever. If you start printing with the lever being lowered (unsecured), the X cutter may hit the XY carriage and result in damage.

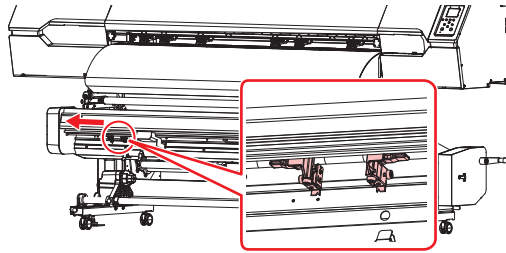

5 Raise the XY clamp lever.

- Hold the media.

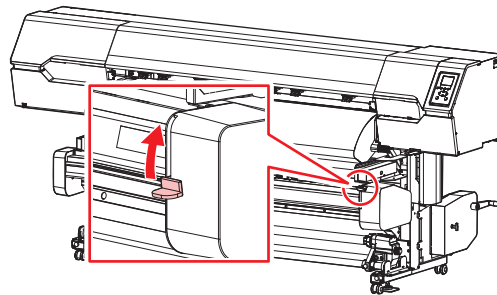
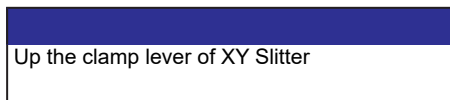

- Note that the carriage moves when the clamp lever is raised.

6 Press the [ENTER] key.

- Cutting starts for the frame for positioning the media guides.

RasterLink [Y Slit] setting: [Normal] [Line Space]



RasterLink [Y Slit] setting: [Nothing]

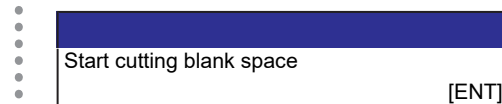

- The cut form will vary depending on the RasterLink [Y Slit] setting.

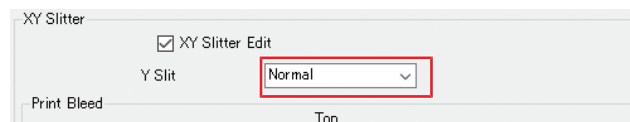

7 Attach the cut-off piece of the frame to the media with tape.

Roll the media to the roll core [ENT]

RasterLink [Y Slit] setting: [Normal] [Line Space]

RasterLink [Y Slit] setting: [Nothing]

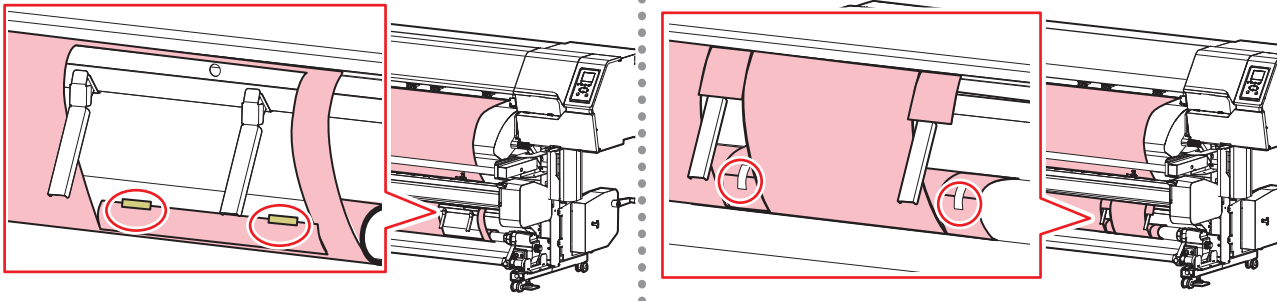

Important!

- Data cannot be printed in succession if it has different slit positions in the scan direction or different slit widths. To print data with different slit positions or different widths, replace the paper core and repeat the process from the beginning (☞ "Loading the Media"(P. 144)).
- When using the XY slitter, Backward feed (backward feed after pressing the ▲ key or view feed) is disabled.

8 Position the media chute.

- ☞ "Using the Media Chute"(P. 139)

9 Position the media guides.

Set media guides [ENT]

RasterLink [Y Slit] setting: [Normal] [Line Space]

RasterLink [Y Slit] setting: [Nothing]

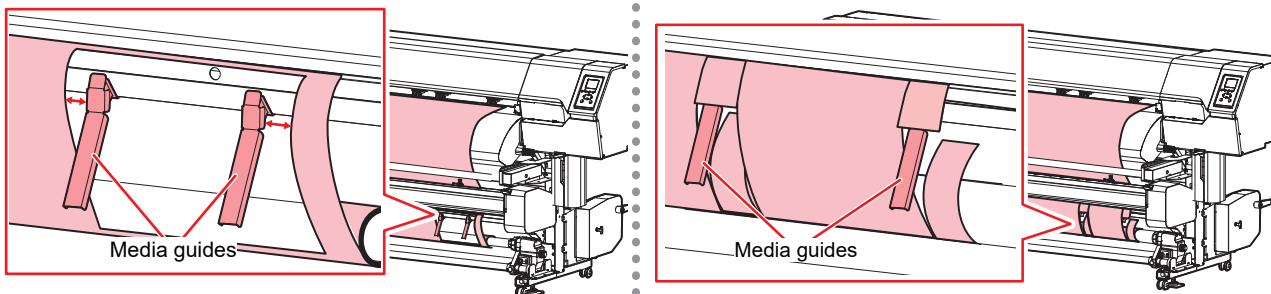

Position the media guides 10 to 20 mm away from the media edges.

- Position media guides in blank space.
- The blank pieces cut off will be ejected to the media chute.

Printing RIP data

The explanation here applies to MIMAKI RIP software (RasterLink).



- Slitting cannot be performed at the same time as "Print&Cut" or "Cut&Print".

1 Click **Q** (Quality).

- This selects a color profile for the media and ink set loaded in this machine.



- For more information, refer to the RasterLink reference guide. <https://mimaki.com/download/software.html>

2 Print image data.

- "Starting Printing"(P. 155)

- (1) Click (Execution) from the function icons on the right-hand side of the screen.
- (2) Select "Immediate Print" or "RIP and Print", then click [Start].



- Once printing is complete, feed the media to slit as far as the rear edge of the print media (final print media in the case of continuous data). In this case, feed the media intermittently (the [Function Setting] > [WhiteSpace Setting] > [Space Feed Mode] setting is disabled).

Starting Printing



- Before starting printing, check to confirm that the remaining amount of cloth wiper is sufficient. Auto maintenance may be performed during printing depending on the ambient temperature in which the machine is located and the [Print Maint.] (P. 178) setting. If the cloth wiper is insufficient, printing will pause without performing auto maintenance. If there is insufficient cloth wiper remaining, replace with a new cloth wiper. "Cloth Wiper Replacement"(P. 219)

1 Send the RIP data from the PC.

- "Preparing RIP data"(P. 97)



- If the message "Attention20A Driver version" appears, install the latest Mimaki driver. <https://mimaki.com/download/inkjet.html>

2 Start printing.

- Printing starts once RIP data is received.

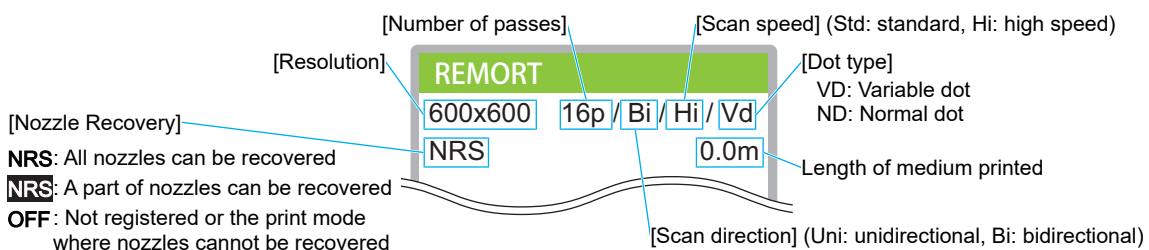



- Print speeds may differ for the same image data, depending on the width of the medium loaded, print origin position, and resolution.
 - If an error occurs, the machine switches to LOCAL mode once printing is completed. Further printing is not possible.
 - The ink used in this machine is warmed before printing. Printing is disabled while the ink is warmed.
-

Pausing Printing

1 Press [LOCAL] while printing is in progress.

- Printing is paused.
- If data is being sent from a PC, data transmission is paused at the PC.

2 Press [REMOTE].

- Printing resumes.
-



- No other functions can be used when printing is paused.
-

5.3 Slitting the Print Media Afterwards



- Slitting cannot be performed at the same time as "Print&Cut" or "Cut&Print".
- Media cannot be slit after it has been laminated.

1. Disable the XY Slitter.

["Disable the XY Slitter."\(P. 159\)](#)

2. Setting the Media Width Detection Type to AUTO

["Setting the Media Width Detection Type to AUTO"\(P. 159\)](#)

3. Loading the Media

The XY slitter is not used. Do not put media through the XY slitter. ["Loading the Roll Media"\(P. 76\)](#)

4. Printing guide (slit) line

Select "Slit Afterwards" in RasterLink. ["Printing guide \(slit\) line"\(P. 148\)](#)

5. Printing RIP data

["Printing RIP data"\(P. 155\)](#)

If you wish to slit from the rear edge of the media, print the guide (slit) line after the RIP data has been printed. ["Slitting from the Media Rear Edge"\(P. 159\)](#)

6. Enable the XY Slitter.

["Enable the XY Slitter."\(P. 160\)](#)

7. Positioning printed media

Put the printed media through the XY slitter. ["Loading the Media"\(P. 144\)](#)

8. Detecting slitting marks

Load the printed media, then detect the marks.  ["Detecting slitting marks"\(P. 161\)](#)

9. Mounting the X cutter and slitting

 ["Mounting the X cutter and slitting"\(P. 164\)](#)

Disable the XY Slitter.

- 1 On the LOCAL mode screen, select [MENU] > [Function Setting], then press the [ENTER] key.
 - The Function Setting menu is displayed.
- 2 Select [Finisher] > [None], then press the [ENTER] key.



Setting the Media Width Detection Type to AUTO

- 1 On the LOCAL mode screen, select [MENU] > [Media Setting], then press the [ENTER] key.
 - The Media Setting menu is displayed.
- 2 Select [Media Information] > [Media Width] > [Detection Type] > [AUTO], then press the [ENTER] key.

Important! • Slitting cannot be performed afterwards if set to "Manual".

Loading the Media



- For details of how to load media, refer to ["Loading the Roll Media"\(P. 76\)](#).

Printing guide (slit) line



- For details of how to print the guide (slitting) lines, refer to ["Printing guide \(slit\) line"\(P. 148\)](#).

Printing RIP data



- For details of how to print RIP data, refer to ["Printing RIP data"\(P. 155\)](#).

Slitting from the Media Rear Edge

Once printing has ended, print the guide (slit) lines to allow slitting from the rear edge of the media.



- When slitting from the rear edge of the media, leave at least 1,000 mm of space from the guide (slit) lines to the rear edge.

- 1 Select the printed image data.

2 Select the slitting method for the Y (scan) direction.

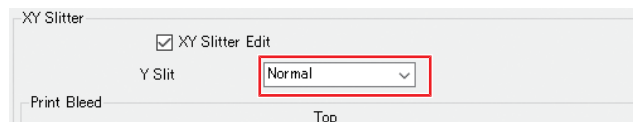

RL_XY Slitter_Y Slit method



- "None" is used when slitting only in the X (scan) direction.

3 Select [Slit Afterwards].

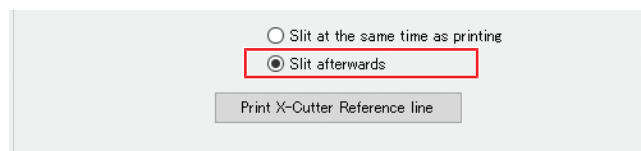

4 Click [Print X-Cutter Reference line].

- Guide (slit) line printing starts.

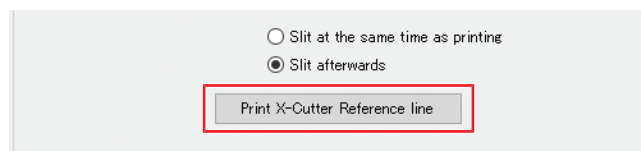

Enable the XY Slitter.

- 1 On the LOCAL mode screen, select [MENU] > [Function Setting], then press the [ENTER] key.
 - The Function Setting menu is displayed.
- 2 Select [Finisher] > [XY Slitter], then press the [ENTER] key.



Positioning printed media

- 1 Position the printed media in the feeding unit.
 - ["Loading the Media"\(P. 144\)](#)

Detecting slitting marks

- 1 On the LOCAL mode screen, select [MENU] > [Function Setting] > [XY Slitter] > [Slit Position Detection].

XY slitter	
Slit Position Adjustment	>
Slit Position Detection	>
Slitting Feed	>

- 2 Select the detection method.

- "Auto Detect"(P. 161): To detect marks automatically
- "Entering Positions"(P. 163): To input the mark positions

Slit Position Detection	
Auto Detect	>
Entering Positions	>

● Explanation of marks

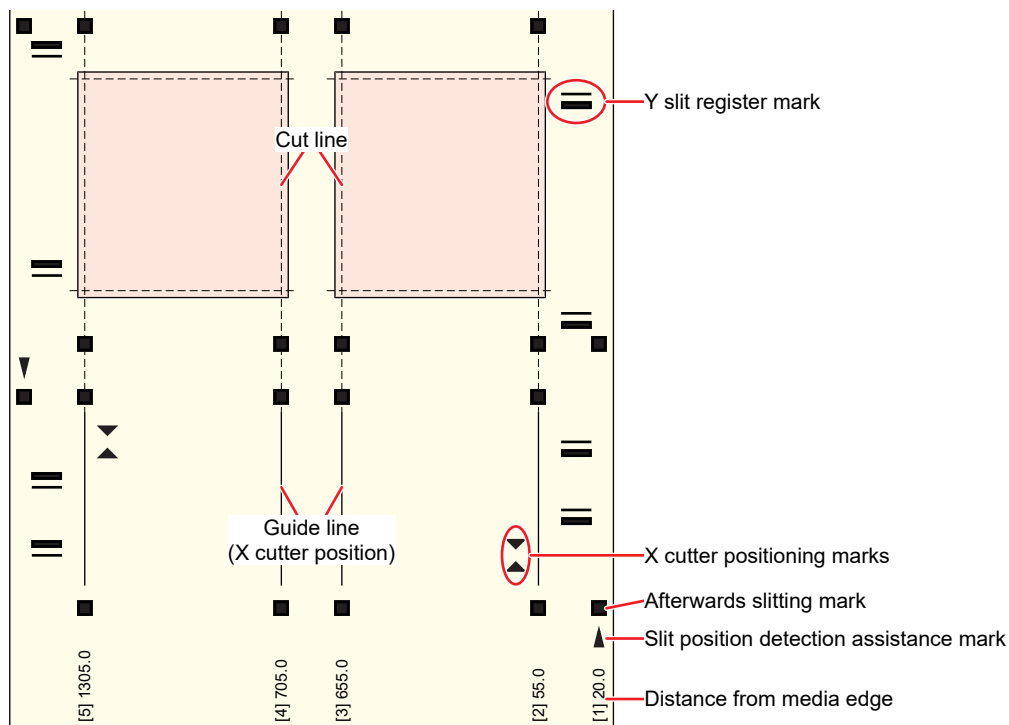

Auto Detect

- 1 Select [Auto Detect].
- 2 Select the color of the slitting marks.
 - Select the color of the printed marks.

Select the color of the detection mark	
	Black
	White

3 Lower the XY clamp lever.

- The carriage moves over the platen.

Up the clamp lever of XY Slitter

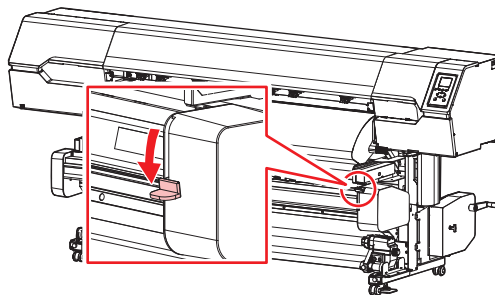

- The XY carriage can be moved by hand when the XY clamp lever is lowered.

4 Move the LED pointer to the center of the mark at the right edge of the media, then press the [ENTER] key.

Slit Position Detection
0.0 0.0

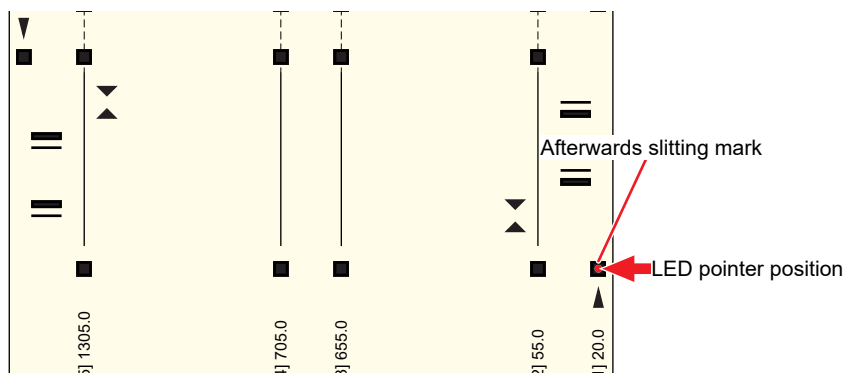



- The slit position detection assistance mark can be used to align the LED pointer with the center of the mark at the right edge of the media more easily.

(1) Align the ▼ mark on the carriage with the slit position detection assistance mark.

◀ ▶ keys: Carriage movement

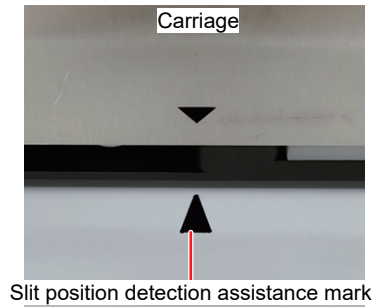

(2) Align the slit position detection assistance mark with the front edge of the carriage.

▲ ▼: Media feed

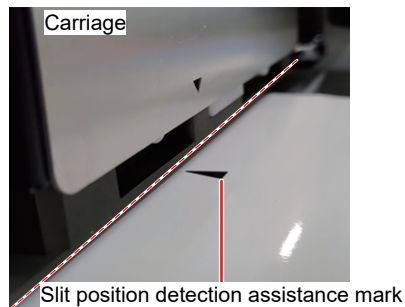

- Align with the center of the Afterwards slitting mark. The mark may not be successfully detected unless aligned with its center.

5 Check the width of the detected slit line, then press the [ENTER] key.

Width (R) : 500 mm
Width (L) : 500 mm
Completed [ENT]



- If mark detection fails, press the [ENTER] key and repeat the process from Step 3 (☞ P. 162 Lower the XY clamp lever).

Slit detection failure [ENT]

Entering Positions

- Select [Enter the position].
- Select the color of the slitting marks.
 - Select the color of the printed marks.

Select the color of the detection mark
Black
White

3 Enter the values printed on the media.

[1]	20.0 mm
[2]	55.0 mm
[3]	555.0 mm
[4]	605.0 mm
[5]	1105.0 mm

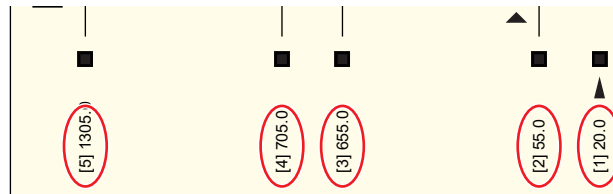

4 Check the width of the slit line entered, then press the [ENTER] key.

Width (R) : 500 mm
Width (L) : 500 mm
Completed [ENT]

Mounting the X cutter and slitting

1 On the LOCAL mode screen, select [MENU] > [Function Setting] > [XY Slitter] > [Slitting Feed].

2 Select the slitting method for the Y (scan) direction.

Y direction slitting method Please Select.
Normal slitting (XY)
No Y slitting (X only)



Be sure to select the slitting method according to the RasterLink [Y Slit] setting.

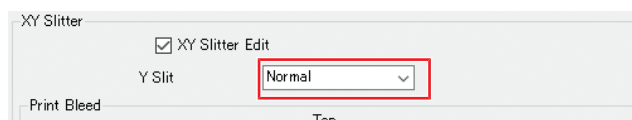

- [Normal] [Line Space]: Normal slitting (XY)
- [Nothing]: Y slitting (X only)

3 Select whether guidelines are present.

- YES: The media is fed. Proceed to the next step.
- NO: Proceed to Step 9 (🔧 P. 167 Raise the XY clamp lever).

Are there guidelines?
NO < > YES

4 Lower the XY clamp lever.

Up the clamp lever of XY Slitter

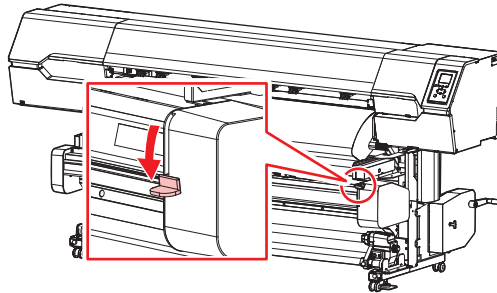

- The XY carriage can be moved by hand when the XY clamp lever is lowered.

5 Press the up/down keys to feed the media.

- Align the groove in the X cutter with the X cutter alignment mark position.

Feed to the X Cutter set position

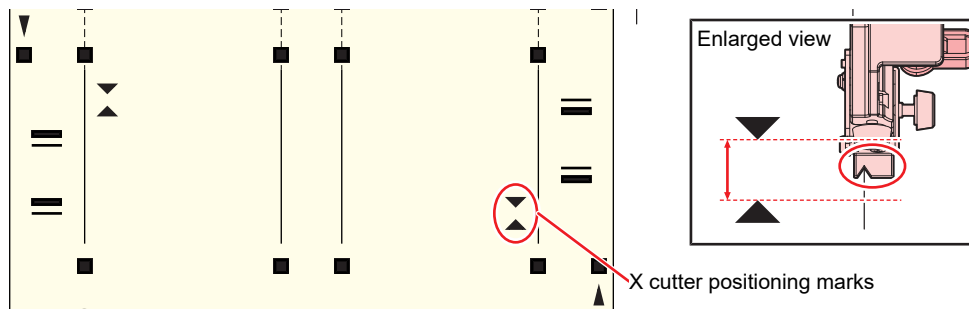

6 Press the [ENTER] key.

7 Move the XY clamps.

- Align the XY clamps with the mark (square hole) positions.

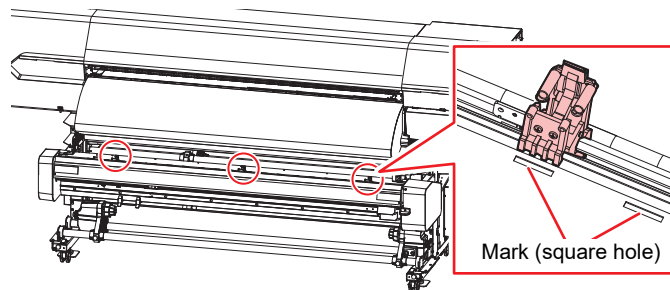



- Position the XY clamps so that the clamp centerlines align with the marks (square holes). The media cannot be transported correctly unless the XY clamp centerlines are aligned with the marks (square holes).

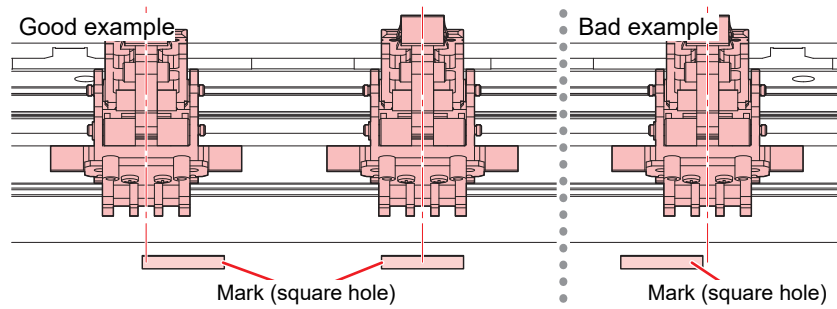

Important! Alter the XY clamp positions according to the RasterLink [Y Slit] setting.

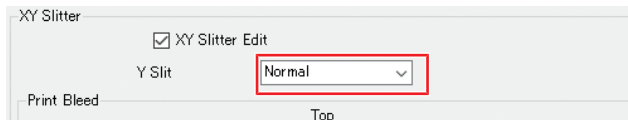

- With "Normal" or "Line Space" selected:**
Always clamp at both edges of the media.
Do not clamp over the print data area.
Unclamp the XY clamps that are not used.

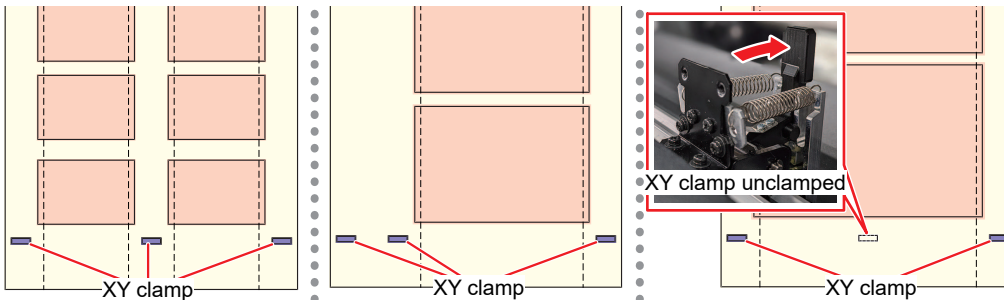

- With "None" selected:**
Clamp over the print data area (inside the X cutter).
Unclamp the XY clamps that are not used.

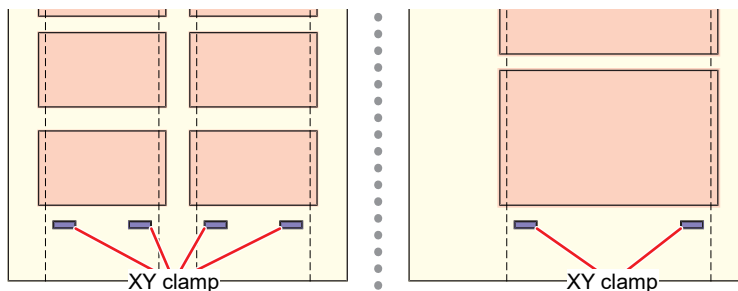

- 8** Align the groove in the X cutter with the printed guide line, embed the blade in the media, then raise the lever to secure.

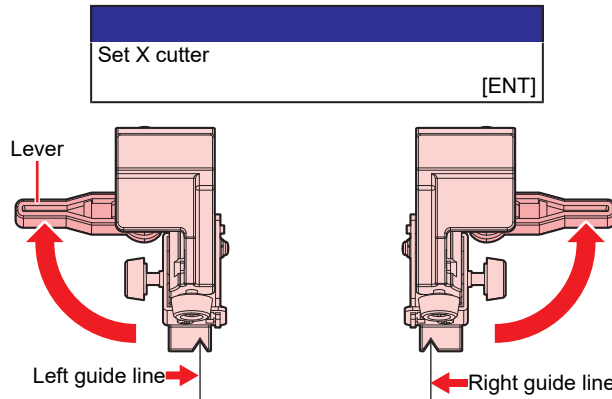

- Avoid touching the cutter blade. Failure to do so may result in injury.



- Slide out the unused X cutter, or move it away from the media and secure it by raising the lever. If you start printing with the lever being lowered (unsecured), the X cutter may hit the XY carriage and result in damage.

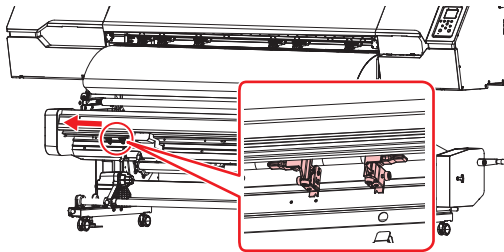

- 9** Raise the XY clamp lever.

- Hold the media.

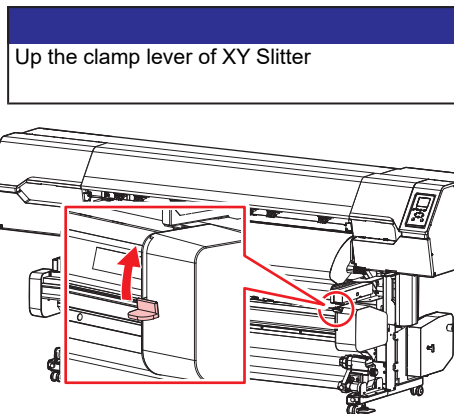

- Note that the carriage moves when the clamp lever is raised.

- 10** Unlock the tension bar of the XY slitter.

- Tension is applied to the media.

11 Press the [ENTER] key.

- Cutting starts for the frame for positioning the media guides.

RasterLink [Y Slit] setting: [Normal] [Line Space]



RasterLink [Y Slit] setting: [Nothing]

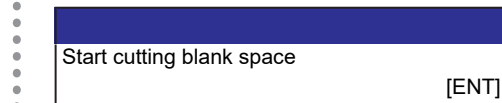

- The cut form will vary depending on the RasterLink [Y Slit] setting.

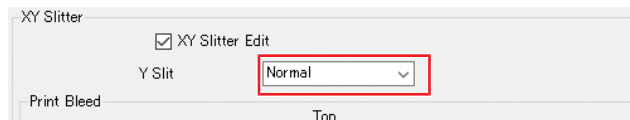

12 Attach the cut-off piece of the frame to the media with tape.

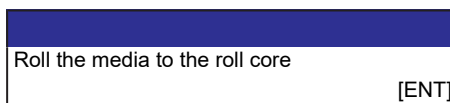

RasterLink [Y Slit] setting: [Normal] [Line Space]

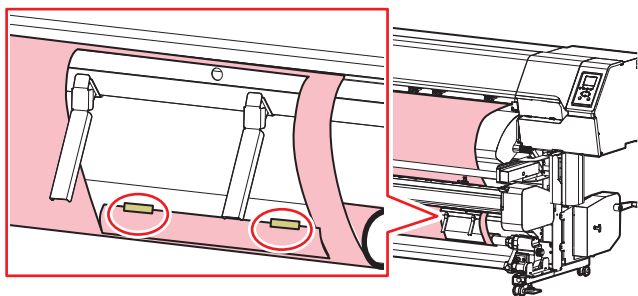

RasterLink [Y Slit] setting: [Nothing]

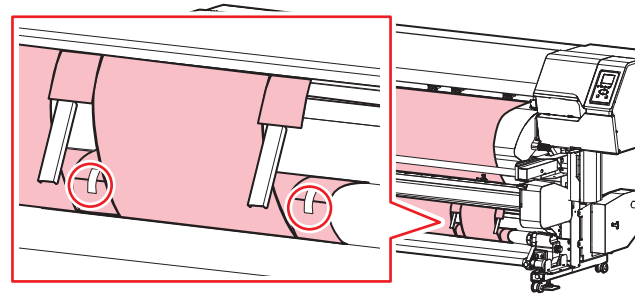

- Data cannot be printed in succession if it has different slit positions in the scan direction or different slit widths. To print data with different slit positions or different widths, replace the paper core and repeat the process from the beginning (🔗 ["Loading the Media"\(P. 144\)](#)).
- When using the XY slitter, Backward feed (backward feed after pressing the ⏮ key or view feed) is disabled.

13 Position the media chute.

- 🔗 ["Using the Media Chute"\(P. 139\)](#)

14 Position the media guides.

Set media guides

[ENT]

RasterLink [Y Slit] setting: [Normal] [Line Space]

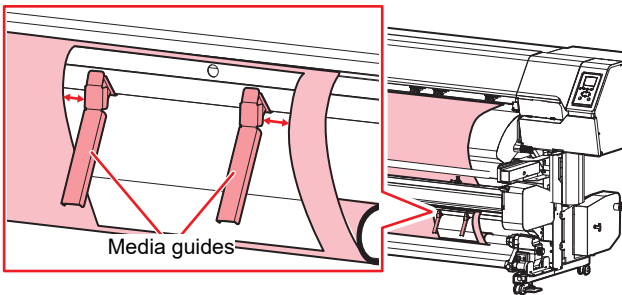

Position the media guides 10 to 20 mm away from the media edges.

RasterLink [Y Slit] setting: [Nothing]

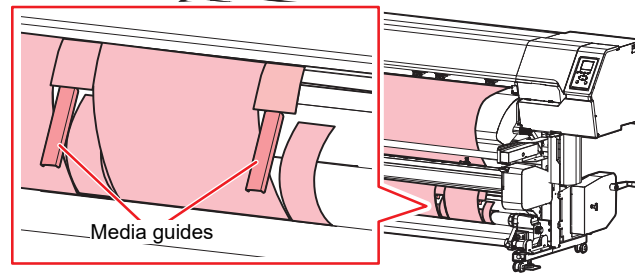

Position media guides in blank space.
The blank pieces cut off will be ejected to the media chute.

15 Press the [ENTER] key.

- Slitting starts.

Width (R) : 500 mm

Width (L) : 500 mm

Start

[ENT]



- Slitting is repeated until reaching the end of the media. To stop slitting, press the [END] key.

5.4 Troubleshooting

If a Media Jam Occurs in the XY Slitter

- 1 Lower the XY clamp lever.

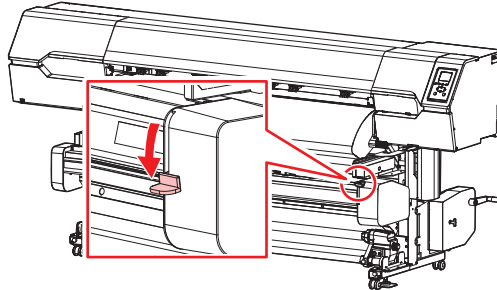

- The XY carriage can be moved by hand when the XY clamp lever is lowered.

- 2 Move the XY carriage away from the media.
- 3 Lower the X cutter lever.

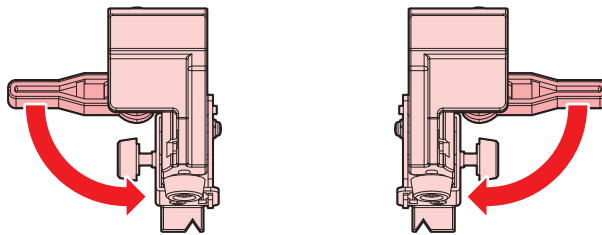

- 4 Move the X cutter to the side and raise the lever to secure it.

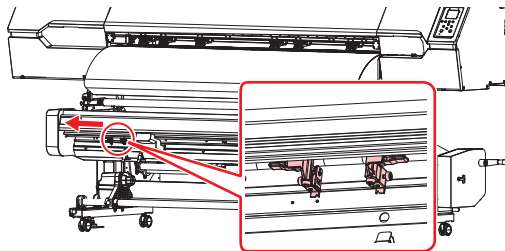

- Avoid touching the cutter blade. Failure to do so may result in injury.

- 5 Use the cutter to cut the media near the tension bar.
- 6 Remove the jammed media.

If the Y Slit Position is Offset

If the Y slit position is offset on the slitted media, adjust the Y slit position by entering a correction value.

- 1 On the LOCAL mode screen, select [MENU] > [Function Setting] > [XY Slitter] > [Slit Position Adjustment].
- 2 Select the position to be adjusted (X or Y position), then press the [ENTER] key.

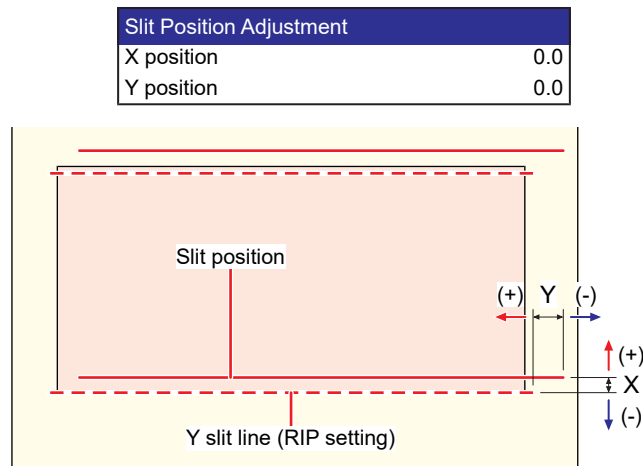

- 3 Enter the adjustment value, then press the [ENTER] key.
 - Entering 0.1 moves the position by 0.1 mm.

Chapter 6 Setup



This chapter

This chapter describes the [MENU] functions.

Media Setting Menu	174	Environment Setting Menu	185
Maintenance Menu	177	Machine Status Menu	187
Registering Nozzle Recovery	179	Cutting Menu	188
Nozzle Check	181	Copying the Last Data	190
Function Setting Menu	182	Preventing Uncut Media	192

6.1 Media Setting Menu

When you use the machine for the first time, the Select Use Media screen is displayed.  "Registering the Media"(P. 85) The media Information and correction value can be saved in advance for specific media.





- To set print conditions for a single use, select "Temporary". The conditions set in "Temporary" are cleared when the machine is restarted.

The user can select to prioritize the settings on the machine or the settings on the PC. Setting individual menus to "Host" prioritizes PC settings. To prioritize settings for this machine, select a setting other than "Host".



- For more information on how to specify RIP software, refer to the RIP software operating manual.

● Menu List

Item	Setting		Details
	*1	*2	
Feed Comp.	-9999 to <u>0</u> to 9999	-	Corrects the media feed amount. Print a pattern and enter the correction amount.  "Feed Correction"(P. 93)
Drop.PosCorrect	-	-	Corrects the drop position for bi-directional printing.  "Correcting the Drop Position"(P. 95)
(Resolution)	*	-	Select the resolution to be corrected. When "All" is selected, correction patterns will be printed for all resolutions. * The available resolutions vary according to the model.
(Correction Value)	-40.0 to <u>0</u> to 40.0	-	Check the pattern and enter correction values.
Auto-correction	-	-	The auto-correction function (DAS: Dot Adjustment System) detects a correction pattern with the sensor and automatically corrects the drop position.
All	-	-	When "All" is selected, "Feed Comp." and "Drop.PosCorrect" are corrected. <ul style="list-style-type: none"> • Check to confirm that the media does not lift up. • Load white and clean media. • Media such as synthetic paper, tarpaulin, or cloth media may not be detected. • Do not send RIP data from the PC during pattern printing. • If automatic correction is unsuccessful, correct the position manually. [MENU] > [Media Setting] > [Feed Comp.] or [Drop.PosCorrect] • UCJV: The following screen display indicates that the print head is being warmed. Printing starts once the proper temperature is reached. <div style="border: 1px solid black; padding: 5px; margin: 10px 0;"> <div style="background-color: #000080; color: white; text-align: center; padding: 2px;">Waiting Temp stabilize</div> <div style="text-align: center;">0:01:20</div> </div> Printing can be started without waiting for the print head to reach the proper temperature by pressing the [ENTER] key while the screen is displayed, but dot printing may be offset.
Feed Comp.	-	-	
Drop.PosCorrect	-	-	

Item		Setting		Details
		*1	*2	
	(Resolution)	*	-	Select the resolution to be corrected. When "All" is selected, correction patterns will be printed for all resolutions, and the drop position is corrected automatically. * The available resolutions vary according to the model.
	Feed Comp.(pull-back)	-9999 to <u>0</u> to 9999	-	This adjustment must be performed before using pullback printing. Corrects the media feed amount specifically for the pullback printing function. <ul style="list-style-type: none"> Print a pattern and enter the correction amount. "Feed Correction"(P. 93)
	UV mode * UCJV only	<u>ON</u> /OFF/ NoPrint	ON	Sets whether to turn on or off the UV-LED lamp. <ul style="list-style-type: none"> ON: Turns on the lamp. OFF: Does not turn on the lamp. NoPrint: Turns on the lamp without printing. (Not used under ordinary conditions)
	UV AdjVal * UCJV only	-50 to <u>0</u> to +50 %	-	The preset UV-LED lamp brightness can be altered. Check the performance (e.g. stickiness and odor) after printing. <ul style="list-style-type: none"> Minus direction: Reduces hardness. Plus direction: Increases hardness.
	MAPS*	-	-	MAPS: Mimaki Advanced Pass System This function disperses the boundaries between passes to make feed streaks between passes less visible. Altering MAPS may alter the color. This function may be less effective with certain types of images. * The MAPS version will vary according to the model.
	MAPS*	<u>AUTO</u> / MANUAL	-	This should normally be set to "AUTO". When set to "MANUAL", the following items are displayed:
	Speed	50 to 100 %	-	Reducing speed will make streaks less visible. However, printing will be slower.
	Smoothing Level (Color)	0 to 100 %	-	Increasing smoothing makes streaks less visible. Make separate settings for color and spot color (white).
	Smoothing Level (Spot)			
	Heater	-	-	Set the heater temperature. "Setting the Heater Temperature"(P. 89) <ul style="list-style-type: none"> TS: Only equipped with a post-heater. (The print heater is optional.) UCJV: Only equipped with a pre-heater.
	PRE	<u>OFF</u> /20 to 60 °C	-	Preheats the media before printing to suppress rapid temperature change.
	PRINT	<u>OFF</u> /20 to 50 °C	-	Helps prevent ink bleeding.
	POST	<u>OFF</u> /20 to 60 °C	-	Allows ink to dry after printing.
	OFF time	<u>None</u> / 0 to 90 min	-	Sets the time before turning the heater off after printing.
	Media Information	-	-	Enter the media information.

Item	Setting		Details
	*1	*2	
Media Type	-	-	Select the media type to be used. The available media types vary depending on the model.
Media Width	-	-	Sets the media width detection method.
Detection Type	<u>AUTO</u> / MANUAL		<ul style="list-style-type: none"> AUTO: The media width is automatically detected with the sensor. MANUAL: ◀ Press ▶ to set the media width manually. <ul style="list-style-type: none"> When media width cannot be detected correctly, set the media width detection method to "MANUAL".
Media Operation Form *CJV/UCJV only	<u>Roll</u> /Leaf	-	Select whether roll media or leaf media is used.
Media Remain	-	-	The remaining roll media amount can be displayed and printed out in REMOTE mode. The print length will be displayed when leaf media is in use.
Media Remain Manage	<u>ON</u> /OFF	-	<ul style="list-style-type: none"> ON: An input screen appears once the media width is detected. ▲ Press ▼ to set the media length. Press the [FUNC3] key on the "Origin Setup" screen to print the date and remaining media amount. OFF: The remaining media amount is not displayed.
Length	0 to 500 m	-	Enter the roll media length.
Detail Setting	-	-	This is used to set various functions.
Vacuum Fan	<u>Host</u> /Weak/ Standard/ Strong	Strong	<p>Sets the force with which the medium is held down.</p> <ul style="list-style-type: none"> This can be used to prevent media jamming and print head damage caused by the media lifting up.
Continuous Running	<u>ON</u> /OFF		<ul style="list-style-type: none"> ON: The media is constantly held down under vacuum. OFF: The media is held down by vacuum only when required, such as during printing and feeding.
Feed Speed	<u>Host</u> /10 to 100 to 200 %	100	<p>Sets the media feed speed.</p> <ul style="list-style-type: none"> Depending on print conditions, the speed may not vary for certain settings. Setting to 100 % or more reduces the time required to complete printing but may affect print quality due to insufficient drying time.
Clamp pressure *JV/TS only	<u>AUTO</u> /Weak/ Standard/ Strong	-	Sets the media clamping pressure.
Pre Feed * TS only	<u>OFF</u> /100 to 500 mm	-	<p>Sets the distance the media is fed backward and forward before printing.</p> <ul style="list-style-type: none"> Moving the media backward and forward prevents it sticking to the platen and minimizes wrinkles in the media.
Media Name Change	-	-	You can change the name of a setting type. The name can include alphanumeric characters or symbols.
Delete MediaInfo	-	-	Delete the set media information.

*1. The default settings are shown underlined.



*2. Settings applied if no settings can be made in the RIP software (host) or if this machine is prioritized.

6.2 Maintenance Menu

This menu is used for maintenance actions. It also lets the user perform nozzle recovery if nozzle clogging persists even after cleaning and nozzle washing.

● Menu List

Item	Setting ^{*1}	Details
Station Maint.	-	This moves the carriage to allow station and print head maintenance.
Carriage Out	-	
Move To Platen Right End	-	Cleans around the station, including the cap, wiper, and NCU. ☞ "Cap Rubber Cleaning"(P. 198) ☞ "NCU Cleaning"(P. 200)
Move To Maint. Space	-	Cleans around the print head. ☞ "Carriage Underside Cleaning"(P. 198) ☞ "Media Sensor Cleaning"(P. 205) ☞ "DAS (Automatic Correction Function) Sensor Cleaning"(P. 202)
Nozzle Wash	1 to 99 min	Washes the print head nozzle surface with maintenance liquid to resolve ejection failures (e.g., nozzle clogging or deflection). ☞ "Print Head Nozzle Washing"(P. 253)
Pump Tube Cleaning	-	Washes the suction pump tube (below the cap). ☞ "Ink Discharge Channel Cleaning"(P. 203)
Custody Wash	1 to 99 min	Perform this step if the machine will not be used for extended periods. The function washes nozzles and drainage channels to maintain the machine in optimal condition. ☞ "When this Printer is Left Unused for a Long Time"(P. 213)
Replace Wiper	-	Use this function when replacing the cloth wiper. Replacing the cloth wiper resets the cloth wiper used length stored in the machine. ☞ "Cloth Wiper Replacement"(P. 219)
Cap Replacement	-	Use this function when replacing the cap. Replacing the cap resets the cap usage time stored in the machine. ☞ "Cap Replacement"(P. 223)
Test Printing	-	Print a test pattern to confirm that the ink prints correctly. Perform head cleaning if you observe any ejection failures (e.g., nozzle clogging or deflection). ☞ "Test Printing"(P. 90)
Cleaning	-	Several head cleaning methods are available. Choose the head cleaning method based on test print results. ☞ "Head Cleaning"(P. 92)
Nozzle Recovery	-	Allows other nozzles to be used for printing if maintenance actions like nozzle washing fail to resolve ejection failures (e.g., nozzle clogging or deflection).
Print	-	Prints a pattern to check nozzle condition and register the nozzle. ☞ "Registering Nozzle Recovery"(P. 179)
Entry	-	Registers the nozzle without printing a pattern.
Reset	-	Initializes the details set.
Test Printing	ON/OFF	Sets whether to perform nozzle recovery before test printing.
Nozzle Check	-	☞ "Nozzle Check"(P. 181)
Printing Check	ON/OFF	Performs nozzle clogging detection before printing starts.

Item	Setting ^{*1}	Details
Check Interval	-	Sets the nozzle clogging detection timing.
Length	0.1 to <u>30.0</u> to 100.0 m	Performs nozzle clogging detection after the length set is reached and before the next print starts.
File	1 to <u>30</u> to 1,000 files	Performs nozzle clogging detection after the preset number of files has been printed and before the next print starts.
Continuation Print	<u>Stop</u> / Continuous	Select whether to stop or continue printing if "Nozzle clogging" is detected.
Action	Off/1 to <u>10</u> to 100	Performs nozzle recovery (cleaning followed by nozzle checking) if "nozzle clogging" is detected.
Cleaning	<u>Soft</u> /Normal/ Hard	Sets the cleaning type.
Retry Count	<u>0</u> to 3 times	Performs nozzle recovery (cleaning followed by nozzle checking) for the specified number of times.
Auto Nozzle Recovery	ON/ <u>OFF</u>	Performs nozzle recovery automatically if "nozzle clogging" is detected. See below if you wish to perform nozzle recovery manually.  "Registering Nozzle Recovery" (P. 179)
Judgment Condition ^{*2}	OFF / <u>1</u> to 64 nozzles	Set the number of nozzles to be detected as clogged before "nozzle clogging" is detected. Up to 16 nozzles per row can be set. The next print will not start if "nozzle clogging" is detected during continuous printing.
Auto Maint.	-	Sets various maintenance actions to be performed automatically. Set the interval between individual maintenance actions. <ul style="list-style-type: none"> If the warning message "Replace Wasteinktank" appears, the automatic maintenance function is disabled.  "Waste Ink Tank Replacement"(P. 242)
Refresh	→	Sets the refresh interval (when a small amount of ink is ejected from the print head nozzles). <ul style="list-style-type: none"> JV/CJV/TS: 0.5/<u>1.0</u> h (W ink set: 0.1 to 0.5 h) UCJV: 0.5 to <u>4.0</u> h
Pump Tube Cleaning <small>*JV/CJV/TS only</small>	<u>OFF</u> / 1 to 168 h	Sets the interval for washing the suction pump tube (below the cap).
Cleaning Interval	→	Sets print head cleaning intervals. This will help prevent nozzle clogging. <ul style="list-style-type: none"> JV/CJV/TS: 1 to <u>48</u> h (W ink set: 1 to <u>12</u> h) UCJV: 1 to <u>24</u> h
Type	<u>Normal</u> /Soft/ Hard	Sets the cleaning type for head cleaning. <ul style="list-style-type: none"> JV/CJV (W ink set) Default: Soft UCJV Default: Soft
Print Maint.	-	Sets the maintenance to be performed automatically midway during printing. Auto cleaning and interval wiping cannot be performed if there is insufficient cloth wiper remaining. If there is insufficient cloth wiper remaining, replace with a new cloth wiper.  "Cloth Wiper Replacement" (P. 219)
Auto Cleaning	-	Sets the conditions to perform head cleaning after the preset number of files are printed.

Item	Setting *1	Details
Setup	File/Length/ Time/ <u>OFF</u>	Sets the conditions to perform head cleaning.
Interval	-	Sets head cleaning intervals.
(File)	1 to 1,000	Cleaning starts when the set number of files is exceeded.
(Length)	→	Cleaning starts when the set print length is exceeded. <ul style="list-style-type: none"> JV/CJV/UCJV: 0.1 to 100.0 m TS: 1 to 1,000 m
(Time)	10 to 240 min	Cleaning starts when the set print time is exceeded.
Type	<u>Normal</u> /Soft/ Hard	Sets the cleaning type for head cleaning. <ul style="list-style-type: none"> JV/CJV (W ink set) Default: Soft UCJV Default: Soft
Cleaning Check	ON/ <u>OFF</u>	Sets whether nozzle checking is performed after head cleaning is completed.
Interval Wiping	<u>OFF</u> /3 to 255 min	Wiping starts when the set print time is exceeded.
Refresh *JV/CJV/TS only	<u>Weak</u> / Standard/ Strong	Select the refresh (flushing) type during printing.
Waste Ink Tank	-	Resets or corrects the waste ink tank usage count. "Waste Ink Tank Replacement"(P. 242)
Reset Waste Ink Volume	-	Resets the waste ink tank usage count. "Replacing the Waste Ink Tank"(P. 242)
Adjust Waste Ink Volume	-	Corrects the waste ink tank usage count. "When "Check Waste Ink Tank" message appears"(P. 242)
Tank Capacity	-	Displays the waste ink tank capacity.
Air PG	-	Expels any air in the ink paths. <ul style="list-style-type: none"> JV/CJV/TS: Use this if Ink End is still displayed after ink replacement. UCJV: Use this in case of considerable nozzle clogging with white ink (dropouts). "There is considerable nozzle clogging with white ink"(P. 254)
Ink Supply Maint. * UCJV only	-	Use this in case of ink supply errors in the white ink path.
White Maintenance	-	Prevents ink sedimentation inside the ink routes. <ul style="list-style-type: none"> Use this when uneven color occurs for the white ink.
Orange Maintenance	-	Prevents ink sedimentation inside the ink routes. <ul style="list-style-type: none"> Use this when uneven color occurs for the orange ink.

*1. The default settings are shown underlined.

Registering Nozzle Recovery

Allows other nozzles to be used for printing if maintenance actions like nozzle washing fail to resolve ejection failures (e.g., nozzle clogging or deflection).



- Nozzle recovery can be specified for up to 20 nozzles per row. The time taken for printing remains unchanged even when nozzle recovery is set.



- Load media at least 500 mm wide. You cannot print the entire pattern if media less than 500 mm wide is used.

- 1 Position the media.**
- 2 On the LOCAL mode screen, select [MENU] > [Maintenance], then press the [ENTER] key.**
 - The Maintenance menu is displayed.
- 3 Select [Nozzle Recovery] > [Print], then press the [ENTER] key.**
 - Print a nozzle recovery pattern.
 - The Select Entry Nozzle screen appears once printing is complete.

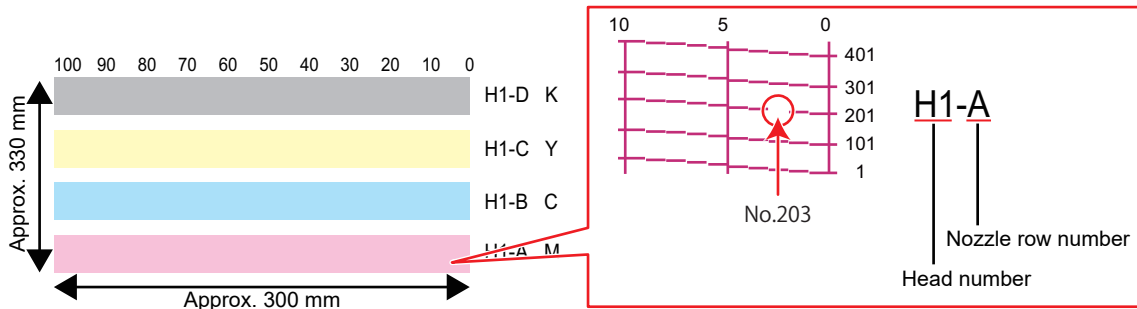

- 4 Select the "head number and nozzle row" for nozzle recovery, then press the [ENTER] key.**

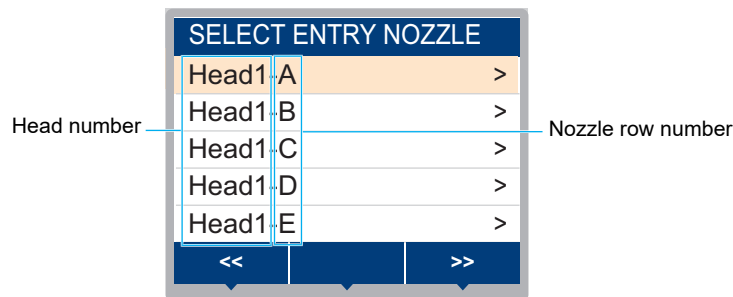

- 5 Enter the "nozzle number" for nozzle recovery, then press the [ENTER] key.**
 - Select the entry number before entering the nozzle number.
 - Nozzle recovery is set.

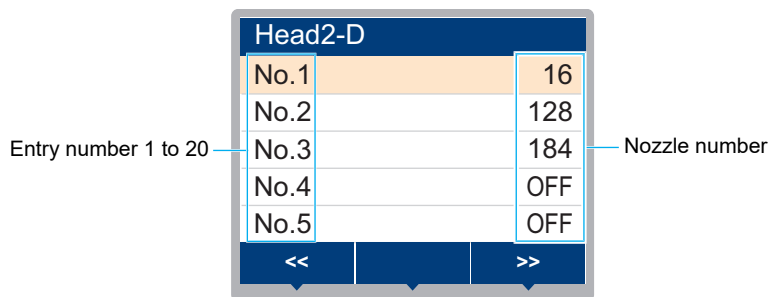

- 6 Press the [ENTER] key once entry is complete.**



- Select [Maintenance] > [Nozzle Recovery] > [Test Print], then select "ON" to perform nozzle recovery and test printing. [☞ "Test Printing"\(P. 90\)](#)

Nozzle Check

This is used to check for nozzle clogging before printing starts. Sets whether to perform maintenance functions automatically if nozzle clogging is detected.

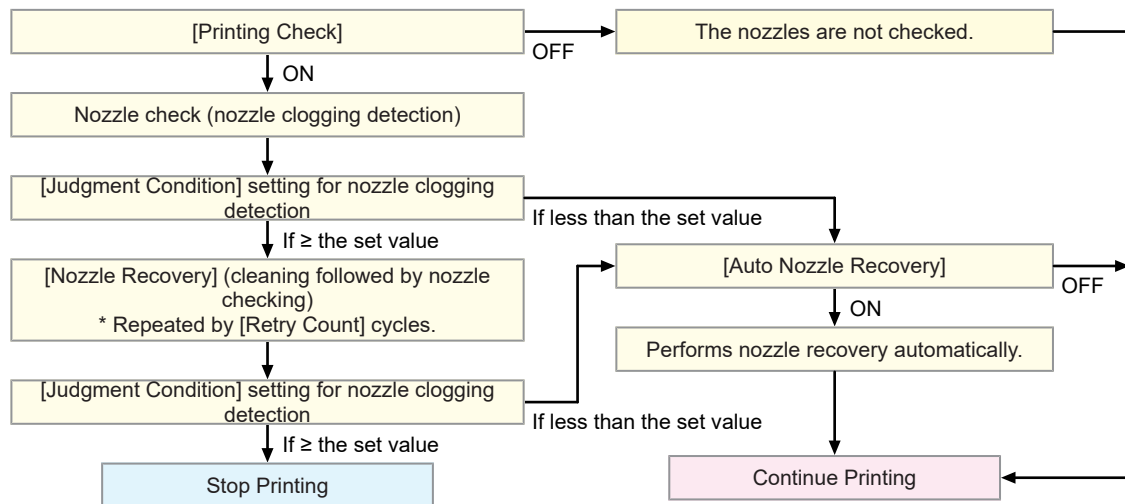





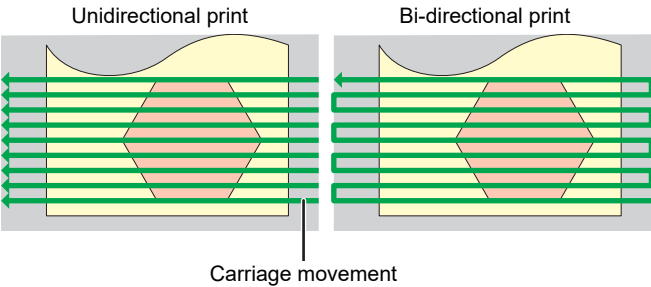
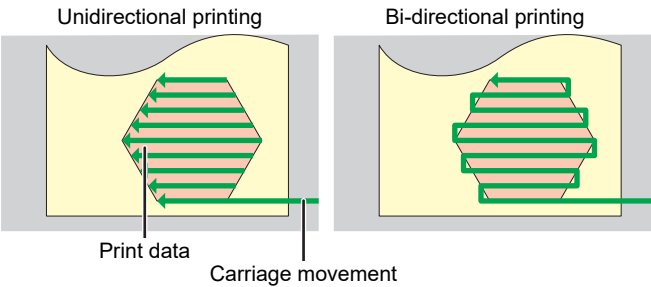

6.3 Function Setting Menu

This is used to set various operations to ensure optimal machine performance.

● Menu List

Item	Setting ^{*1}	Details
Logical Seek	<u>Host</u> /OFF/ON	<p>Sets the range of carriage movement.</p> <ul style="list-style-type: none"> OFF: Machine size area  <p>Carriage movement</p> <ul style="list-style-type: none"> ON: Print data area  <p>Print data Carriage movement</p>
Take-up Unit	-	Sets the take-up unit operation.
Take-up Unit	<u>ON</u> /OFF	Set to "OFF" if the take-up unit is not used.
Take-up SW	<u>Continuous</u> / Temporary	<p>Sets the function performed by the ON/OFF button on the take-up unit. ☞ "Take-up unit"(P. 67)</p> <ul style="list-style-type: none"> Continuous: Press the button to start/stop the take-up unit. Temporary: The take-up unit operates only while the button is pressed. The unit stops when the button is released.
Drying Time *JV/CJV/TS only	-	Sets the time for ink to dry.
Scan	<u>Host</u> /0.0 to 9.9 sec	<p>Sets the stop time of the carriage after each scan.</p> <ul style="list-style-type: none"> The MIMAKI RIP software (RasterLink) indicates this as "Pause Time per Scan".
Print End	<u>Host</u> /0 to 120 min	<p>Sets the stop time after printing. The next data is printed once the set time has elapsed.</p> <ul style="list-style-type: none"> The Mimaki RIP software (RasterLink) does not allow the user to specify Print End. If the machine is set to "HOST", the time will be "0".
Power Setting	-	Sets the times to turn the power on and off automatically.
Auto Power-off	5 to <u>15</u> to 60 min	Sets the time until the power is automatically turned off.
Auto Power-on	-	Sets the time to automatically turn on the power.
Setup	<u>ON</u> /OFF	Sets whether to turn on or off the power.
Time	<u>0:00</u> to 23:59	Sets the time to turn on the power.

Item		Setting *1	Details
	Day	Monday to Sunday	Sets whether to turn on or off the power on each day of the week.
	Nozzle Check	<u>ON</u> /OFF	Automatically executes the nozzle check function when the machine is started with auto power-on. Performs nozzle recovery (cleaning followed by nozzle checking) if "nozzle clogging" is detected.
	Cleaning	<u>Soft</u> /Normal/ Hard	Sets the cleaning type.
	Retry Count	<u>0</u> to 3 times	Performs nozzle recovery (cleaning followed by nozzle checking) for the specified number of times.
Top Blower *JV/CJV/TS only		<u>ON</u> /OFF	Sets the blowing fan operation during printing.
	Strength	<u>AUTO</u> /Low/ High	Sets the blowing fan wind strength.
Drying/Exhaust Fan		-	Set when the deodorizing fan unit (option) is used.  "Deodorizing fan unit"(P. 294)
	Stop Time	OFF/ <u>10</u> to 120 min	Sets the time during which the deodorizing fan operates after printing. After the set time passes, the fan stops.
	ON/OFF	ON/ <u>OFF</u>	Set to "ON" to operate the deodorizing fan when printing is not performed.
Use PR Number Query *CJV/UCJV only		<u>ON</u> /OFF	Sets whether to display the screen for entering the number of pinch rollers to be used after media width detection. <ul style="list-style-type: none"> ON: Displays the input screen. OFF: The "host" takes priority. Set this to "OFF" when configuring pinch roller pressure settings on this machine.  "Setting the Pressure and Number of Pinch Rollers to Use"(P. 87)
WhiteSpace Setting		-	Sets the offset value from the media left and right standard margins (15 mm). <ul style="list-style-type: none"> The left and right margins should be set to at least -5 mm when using the media holder. This eliminates the risk of printing on top of the media holder. The Mimaki RIP software (RasterLink) does not allow the user to specify margins. If the machine is set to "Host", the offset value will be "0 mm" for the left and right margins.
	Margin	-	<ul style="list-style-type: none"> The left and right margins should be set to at least -5 mm when using the media holder. This eliminates the risk of printing on top of the media holder. The Mimaki RIP software (RasterLink) does not allow the user to specify margins. If the machine is set to "Host", the offset value will be "0 mm" for the left and right margins.
	Margin/Left Margin/Right	<u>Host</u> /-10 to 85 mm	
Space Btwn PP.		<u>None</u> /10 to 500 mm	The space between prints can be eliminated for continuous printing. <ul style="list-style-type: none"> Reducing the space length may cause media sagging, resulting in discrepancies in the distance the media is fed.
Space Feed Mode		<u>Intermittent</u> / Continuous	Alters the feed method for blank space included in the image data. <ul style="list-style-type: none"> Intermittent: Uses intermittent feeding based on the timing of a fraction of the pass. Continuous: Feeds forward by skipping blank parts.
View Feed		<u>ON</u> /OFF	Sets whether or not to feed the media forward to view the print results—for example, during test printing.
Feeding Before Cut		<u>ON</u> /OFF	Sets whether to feed media before cutting the media.
Illumination		-	Turns the light inside the printer on and off.

Item		Setting *1	Details
	LightingUp Type	<u>Auto</u> /Manual	Sets whether to turn the light on or off during printing and when the cover is opened.
	LightingUp Extention	None/1 to <u>5</u> to 10 min	Displayed when LightingUp Type is set to Auto. Sets the time during which the light is turned on after printing.
	Start Up Lighting	ON/ <u>OFF</u>	Sets whether to turn the light on or off when the power supply switch is turned on.
Auto Remote		<u>ON</u> /OFF	Sets whether to automatically switch to REMOTE mode and start printing if data is received locally.
Finisher *JV/CJV/(UCJV: option) only		<u>None</u> /XY Slitter	Selects the unit connected. The settings are displayed for the selected unit.
XY slitter		-	Sets the XY slitter adjustments and functions.  "Using the XY Slitter"(P. 135)
	Slit Position Adjustment	-	Adjusts the Y slit position.  "If the Y Slit Position is Offset"(P. 171)
	X position	-5.0 to 5.0	Adjusts the X position of the Y slit.
		Y position	-5.0 to 5.0
	Slit Position Detection	-	Detects [Afterwards slitting mark].  "Detecting slitting marks"(P. 161)
	Slitting Feed	-	Displays the procedures from X cutter setting to slitting when slitting afterwards.  "Mounting the X cutter and slitting"(P. 164)
Ionizer		<u>ON</u> /OFF	Set when the ionizer (option) is used.  "Ionizer"(P. 288) The machine prints while the ionizer removes static electricity from media. The electrode probes are not on unless the machine is printing.

*1. The default settings are shown underlined.

6.4 Environment Setting Menu

This is used to set various operations to ensure optimal machine performance.

● Menu List

Item	Setting ^{*1}	Details
LANGUAGE	English / 日本語 / Deutsch / Português / Español / Italiano / Korean	Sets the display language.
Time Set	-20 to 0 to +4 h	Sets the current time and date. (With respect to JST) <ul style="list-style-type: none"> This can be set within the range of -20 to +4 hours.
Key Buzzer	ON/OFF	Sets an audible tone when keys are pressed. <ul style="list-style-type: none"> Audible signals indicating errors, warnings, and operation end cannot be muted, even if "OFF" is selected for this setting.
Unit Setting	-	Set the display units.
Temp.	°C/°F	Sets the display unit for temperature (Celsius/Fahrenheit).
Length	mm/inch	Sets the display units for length and area. <ul style="list-style-type: none"> Some items are displayed in "mm" even if "inch" is selected.
Network	-	Sets the network address. The machine must be restarted to enable this setting.
Check IP Address	-	Displays the machine's current IP address. <ul style="list-style-type: none"> It may take some time to determine the IP address. If the IP address cannot be determined, the display will indicate "0.0.0.0".
Check MAC Address	-	Displays the machine's current MAC address.
DHCP	ON/OFF	Select "ON" to use the IP address assigned by the DHCP server.
AutoIP	ON/OFF	Select "ON" to use the IP address set by the AutoIP protocol. Note that DHCP takes priority if DHCP is set to "ON".
Ip Address	-	Sets the IP address used by the machine. <ul style="list-style-type: none"> This can be set when both [DHCP] and [AutoIP] are disabled.
Default Gateway	-	Sets the default gateway used by the machine. <ul style="list-style-type: none"> This can be set when both [DHCP] and [AutoIP] are disabled.
DNS Address	-	Sets the DNS server address used by the machine. <ul style="list-style-type: none"> This can be set when both [DHCP] and [AutoIP] are disabled.
Sub Net Mask	-	Sets the subnet mask used by the machine. <ul style="list-style-type: none"> This can be set when both [DHCP] and [AutoIP] are disabled.
Remote Control	-	An application (MRA: Mimaki Remote Access) is required to use the remote control function. MRA is a remote access tool installed on a computer or smartphone that allows viewing of product information and panel operation from a remote location away from the machine (within the same network segment).
Setup	Enable/Disable	Enable/disable remote control.







Item	Setting ^{*1}	Details
	PIN code	<p data-bbox="614 185 1332 246">Enter the same PIN code as MRA. The PIN code is used for authentication between the machine and MRA.</p> <ul data-bbox="630 253 1332 313" style="list-style-type: none"> <li data-bbox="630 253 1332 313">• When the machine is set to "0000", MRA can access the machine with any PIN code.
	KeyLife	Sets the time interval before disconnecting the machine and MRA if no operations are performed using MRA.
Machine Reset	-	Initializes the details set.

*1. The default settings are shown underlined.

6.5 Machine Status Menu

This is used to check machine information.

● Menu List

Item		Details
Usage	Roll Wiper Remain	Displays the remaining amount of cloth wiper. <ul style="list-style-type: none"> To reset the remaining amount of cloth wiper, press the [FUNC2] key while the amount is displayed.
	Capping Use Days	Displays the number of days since the cap was replaced.
	Waste Ink Tank	Displays the approximate level of waste ink in the waste ink tank as a percentage. <ul style="list-style-type: none"> To reset waste ink levels, press the [FUNC1] key while the level is displayed.
	Print Length	Displays the total length printed.
	Print Area	Displays the total area printed.
	Use Time	Displays the total time the power has been turned on.
	UV Lamp * UCJV only	Displays the total time the UV-LED lamp has been used.
Maintenance History	Maintenance	Displays a record of maintenance function execution (up to 10). <ul style="list-style-type: none"> Cleaning  P. 92, Wash Wiping  P. 92, Pump Tube Cleaning  P. 203, Nozzle Washing  P. 253, Circulation
	Replace Wiper	Displays a record of cloth wiper replacement (up to 5).  P. 219
	Ink replacement	Displays a record of ink pack replacement for each ink slot (up to 5).  "Replacing Ink"(P. 46) <ul style="list-style-type: none"> Slot 1 to 8
Version	Displays the machine firmware and other versions.	
Error History	Displays the error and warning history. <ul style="list-style-type: none"> These are listed in chronological order. Use the keys to cycle through occurrence time/date and error/warning information. 	
List	This is used to print machine information.	

6.6 Cutting Menu

This is for setting the various cutting function operations (CJV/UCJV only).

● Menu List

Item	Setting ^{*1}	Details
Mark Detect	-	Enter the conditions of the printed register marks.
Detect	ON/OFF	Set this to ON to cut cutting data with register marks.
Form	Type1/Type2/ Zero Margin	Select three types of register mark shapes. "Register Marks"(P. 124)
Size	5 to <u>10</u> to 40 mm	Set the register mark length (B). "Standards for Register Mark Length and Line Width"(P. 125)
Offset X	-5.00 to 5.00 mm	Change the position of the register mark origin. If the cut position shifts in the same direction, change the position of the origin.
Offset Y	-5.00 to 5.00 mm	<ul style="list-style-type: none"> • If "ERROR C37 Mark Org" is displayed, change the layout by referring to the following. "Reading Range of Register Marks"(P. 127)
Detect End Key Start	ON/OFF	If you press the [END] key on the LOCAL mode screen, the cutter unit moves over the platen so that register marks can be detected.
Sensor sensitivity	1 to 7	Check the sensitivity of the register mark sensor. Normally, set this to "4". <ul style="list-style-type: none"> • If it cannot detect the register marks: Increase sensitivity. • If it mis-detects the register marks: Decrease sensitivity.
Mark FillUp	ON/OFF	When the "Fill around the registration marks" function of the RIP software is enabled, set this to "ON".
Detect Area	-	Sets the automatic register mark detection area.
Scan Dir.	Default/0 cm to machine width	Sets the scan direction for automatic register mark detection. <ul style="list-style-type: none"> • When set to [DEFAULT], the detection operation is performed at half the media width.
Feed Dir.	<u>10</u> to 50 cm	Sets the media feed direction for automatic register mark detection.
Offset X	<u>0</u> to 100 cm	Sets the automatic detection start position for the next register mark.

Item	Setting ^{*1}	Details
Cut Mode	<u>Normal</u> / HighSpd/ Quality	Sets the cutting quality. <ul style="list-style-type: none"> • Normal: Normally, use this setting. • HighSpd: This cuts media in a short period of time. This is not suitable for use with heavy media. • Quality: This puts priority on the cutting quality, and limits the cutting speed to 20 cm/s. Select "Quality" when cutting the following data. <ul style="list-style-type: none"> – Text not larger than 10 mm – Data with many acute angles – Intricate data (However, cut lines may be jagged depending on the data. If this occurs, change the setting to "HighSpd" to make cut lines smoother.)
Copy	-	Cut the data stored in the receive buffer of the machine by the specified number. 📖 "Copying the Last Data"(P. 190)
No. Copies	1 to 999	Enter the number of copies.
Interval	0 to 30 mm	Select the cut data interval.
Tool Change	-	Select this when replacing tools. 📖 "Installing Cutting Tools"(P. 108)
Setup Sub Menu	-	Useful functions when cutting.
Division Cut	-	Allows data larger than the sheet width to be divided before cutting.
Division Cut	<u>OFF</u> /X/Y	Sets the direction for division cutting. <ul style="list-style-type: none"> • Y: Carriage scan direction • X: Media feed direction. Helps reduce offsets due to media that meanders. Division cutting is performed if the division cut + cross cut is exceeded.
Division Cut	<u>50</u> to 500 cm	Division cutting is performed if this setting is exceeded.
Cross Cut	<u>0</u> to 50 mm	Set the length for overlap cutting.
Frame Cut	<u>OFF</u> /ON	Sets whether or not to automatically cut a frame to match the cut data.
Mark Cut	<u>OFF</u> /ON	Sets whether or not to add marks for use as guides when pasting together division-cut media.
Up Speed	-	Set the movement speed of the media and carriage while the tool is up.
Up Speed X	<u>AUTO</u> /5 to 30 cm/s	Sets the media feed speed. Setting a slower speed can reduce media offsets.
Up Speed Y	<u>AUTO</u> /5 to 30	Sets the carriage scan speed.
Dummy cut	<u>ON</u> /OFF	Cuts the media to make the cutting blade face a certain direction after media detection or tool changes. (Performs a dummy cut in front of the pinch rollers which are closest to both ends of the cutter unit.) <div data-bbox="619 1778 954 1980" data-label="Image"> <p>The diagram shows a yellow rectangular area representing the cutter unit. Inside, a blue rectangle is labeled 'Pinch roller'. Below it, a vertical line with a horizontal tick at the bottom is labeled 'Dummy cut'.</p> </div>

Item	Setting ^{*1}	Details
		If you wish to avoid damage to the media or cut cut-out characters, set this to OFF. Perform test cutting to adjust the direction of the cutting blade. "Test Cutting"(P. 117) If the tool condition is set to "PEN", dummy cutting is disabled.
Sheet Type	<u>Standard/</u> Heavy	Set the weight of the set media.
Adj-prs Offset	-9 to <u>0</u> to 9	When cutting the corners, the pressure is automatically decreased (by about 5 g) to prevent the media from lifting up. As a result, the cutting blade might not rotate smoothly and may leave uncut parts. Adjust the pressure for cutting the corners if they are left uncut.
Vacuum Fan	<u>Weak/</u> Standard/ Strong/OFF	Sets the force with which the medium is held down during cutting. Ordinarily, use "Weak".
Over Cut	<u>OFF/0.1</u> to 1.0 mm	Overlaps the start and end points so that no part of the media is left uncut. "Preventing Uncut Media"(P. 192)
Corner Cut	ON/ <u>OFF</u>	Performs over cutting at corners other than the start and end point. "Preventing Uncut Media"(P. 192)
Curve Mode	<u>Fast/</u> Slow	If the cut line becomes twisted, set this to "Slow". This can prevent twisting but decreases cutting speed.
Setup Reset	-	Initializes the details set.
Maintenance	-	
Marks Sensor	-	
Sensor Check	-	Check the responsiveness of the register mark sensor. "Adjusting the Position of the Register Mark Sensor"(P. 258)
Pointer Offset	-	Adjust the position of the light pointer when the positions of the register mark sensor and light pointer do not match. "Correcting the LED Pointer Position"(P. 259)
Sample Cut	-	Use a sample stored in the unit for cutting to troubleshoot problems when data cannot be cut properly. "Investigating the Cause of Cutting Failures"(P. 260)
Auto Media Cut	-	Cuts the specified number of media sheets at the specified length.
Cut Interval	10 to 10,000 mm	Sets the cut length.
Front Cut Off	0 to 500 mm	The front edge of the media can be cut off if cut diagonally. Sets the cut length.
Count	1 to 9,999 times	Sets the number of media pieces to be cut.
Scale Adjust	-	When printing and cutting without register marks, perform corrections when the media deviates to the left or right side of the scan direction.

*1. The default settings are shown underlined.

Copying the Last Data

You can cut the data stored in the receive buffer of the machine by the specified number (up to 999 sheets).

- The last cutting data is stored in the receive buffer. When new data is received, the already saved data is overwritten.
- Reset the origin before executing the copy function. Failure to do so will result in overlap cutting.

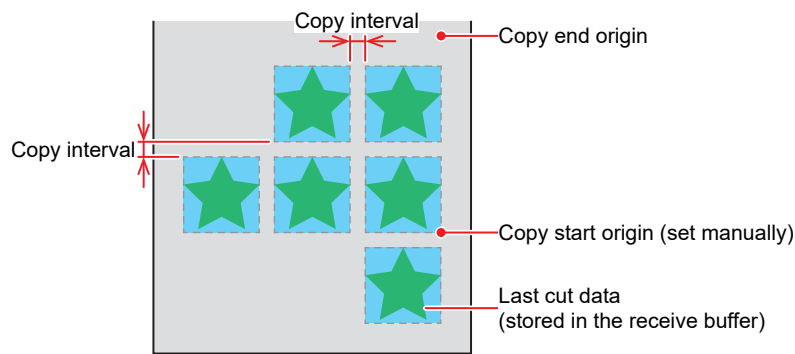

- The machine cuts the specified number of sheets of the divided cut data without separating the data.
- With the following data, only one sheet can be cut, regardless of the number of copies specified.
 - (1) Data received from MIMAKI RIP software (RasterLink).
 - (2) Data for which "Sheet Feed Origin Renewal" has been selected in the MIMAKI cutting software (FineCut).



- When sending the cut data from the PC, wait for at least 5 seconds before sending the next data. If the next data is sent within 5 seconds, both pieces of data may be copied.

Preventing Uncut Media

Overlapping the start and end points can prevent the media from being left uncut. Configure this setting for very flexible media.

If the setting is too large, the print may also be cut. Alter the setting while checking using a test cut.  ["Test Cutting"](#)(P. 117)

● Over Cut

The machine cuts the media in front of the cutting start point by the set value. The media is overcut by the set value at the end point.

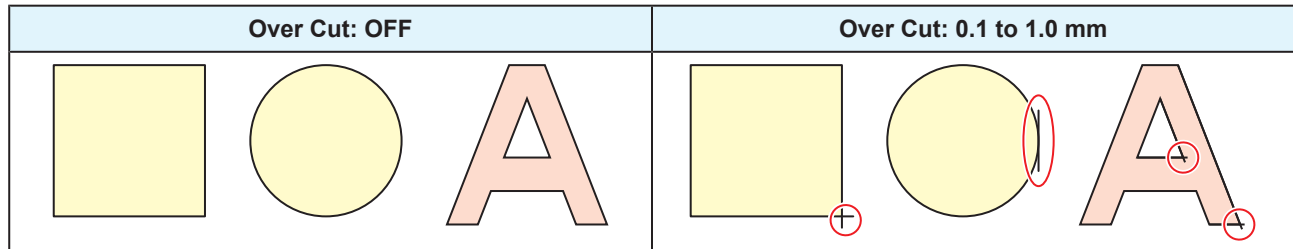

● Corner Cut

When the Over Cut setting value is entered, Corner Cut is displayed. The machine performs over cutting at corners other than the start and end point.

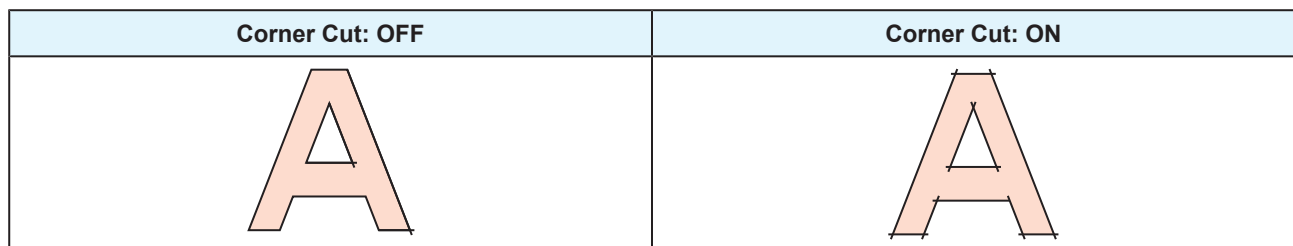

Chapter 7 Maintenance



This chapter

To ensure years of precise performance, maintain the machine periodically based on frequency of use.

Read the maintenance precautions thoroughly before maintaining this product.

Maintenance Precautions	194	Replacement of Consumable Item	217
Maintenance Methods	195	Consumable Item Replacement Timing	217
Maintenance Items and Timing	195	Cloth Wiper Replacement	219
Ink Maintenance	197	Cap Replacement	223
Cap Rubber Cleaning	198	Replacing the Absorber Around the Station	
Carriage Underside Cleaning	198	225
Cloth Wiper Area Cleaning	200	Exhaust Fan Filter Replacement	229
NCU Cleaning	200	Blowing Fan Filter Replacement	230
DAS (Automatic Correction Function) Sensor		Pinch Roller Replacement	231
Cleaning	202	Media Holder Replacement	232
Ink Discharge Channel Cleaning	203	Media Cutter Replacement	234
Media Sensor Cleaning	205	Y Cutter Replacement (XY Slitter)	236
Media Cutter Cleaning	206	X Cutter Replacement (XY Slitter)	237
Media Holder Cleaning	207	Media Edge Guide Film Replacement	239
Jam Sensor Detecting Plate Cleaning	208	Ink Supply Unit Ink Absorber Replacement	
Platen Cleaning	209	240
Cover (Exterior) Cleaning	209	Waste Ink Tank Replacement	242
Cleaning the Mist Filter	210	Mist Filter Replacement	245
Blowing Fan Filter Cleaning	211	UV-LED Glass Replacement	246
When this Printer is Left Unused for a Long		Cutter for Cutting Machine	247
Time	213	Pen Line Replacement	247
		Bottle Cap Replacement	248

7.1 Maintenance Precautions



- This machine includes parts that must be replaced periodically. We therefore recommend taking out a maintenance contract. Carry out maintenance periodically and replace consumable items to prevent quality defects and accidents.

⚠ WARNING



- Clean periodically. Debris and dust will accumulate on electrical components when the machine is used for extended periods. There is a risk of failure, electric shock, or fire due to current leakage.
- Do not clean by blowing—e.g., avoid using air blowers. Doing so may lead to failure, electric shock, or fire involving the machine if airborne debris or dust gets inside electrical components. Wipe using a soft cloth soaked in diluted neutral detergent and thoroughly wrung out. A vacuum cleaner may also be used for cleaning.



- Be careful to prevent liquids from getting inside the machine. Otherwise there is a risk of failure, electric shock, or fire.

⚠ CAUTION



- The UV-LED unit becomes extremely hot. Be careful not to touch the LED after it has been turned off until it has sufficiently cooled.



- For heavy soiling, wipe using a soft cloth soaked in diluted neutral detergent and thoroughly wrung out.



- Pay close attention to ventilation and be sure to wear safety glasses, gloves, and a mask when handling ink, maintenance liquid, waste ink, or other solutions used with the machine. Leaking ink may adhere to the skin or get into the eyes or mouth.



NOTICE



- Never touch the print head nozzle surface. Do not allow water or alcohol to come into contact with the print nozzle surface. This will increase the risk of machine failure or ejection failures (e.g., nozzle clogging or deflection).
- Do not use cotton swabs to clean around the head or carriage. Fibers from cotton swabs may adhere to the head nozzle surface and lead to ejection failures (e.g., nozzle clogging or deflection).
- Do not splash ink or maintenance liquid on the covers. Exposure to splashing ink or maintenance liquid may damage or deform the cover.
- Do not use benzine, thinner, or any chemical agent containing abrasives. Use of these chemicals may result in damage to or deformation of parts.
- Do not move the carriage by hand. To move the carriage, use the carriage out function on the menu.









7.2 Maintenance Methods

Maintenance Items and Timing

● JV/CJV/TS

Timing	Item
Every three days, at the start of the work	Shake the ink. "Ink Maintenance"(P. 197)
At the end of the week's work	Clean the cap rubber. "Cap Rubber Cleaning"(P. 198)
	Clean the underside of the carriage. "Carriage Underside Cleaning"(P. 198)
	Check the waste ink levels in the waste ink tank. "When "Check Waste Ink Tank" message appears"(P. 242)
At the end of two weeks' work * TS only	Clean the blowing fan filter. "Blowing Fan Filter Cleaning"(P. 211)
Every month	Clean around the cloth wiper. "Cloth Wiper Area Cleaning"(P. 200)
	Clean the NCU. "NCU Cleaning"(P. 200)
	Clean the DAS sensor. "DAS (Automatic Correction Function) Sensor Cleaning"(P. 202)
	Clean the ink discharge channel. "Ink Discharge Channel Cleaning"(P. 203)
	Clean the media sensor. "Media Sensor Cleaning"(P. 205)
	Clean the media cutter. "Media Cutter Cleaning"(P. 206)
	Clean the media holder. "Media Holder Cleaning"(P. 207)
	Clean the jam sensor detecting plate. "Jam Sensor Detecting Plate Cleaning"(P. 208)
	Clean the platen. "Platen Cleaning"(P. 209)
	Clean the cover (exterior). "Cover (Exterior) Cleaning"(P. 209)
When not used for more than a week	Clean the cap and wash the ink discharge channels. After cleaning, store without turning off the main power supply. "When this Printer is Left Unused for a Long Time"(P. 213)

● UCJV

Timing	Item
Periodically	Shake the ink.  "Ink Maintenance"(P. 197)
At the end of the week's work	Clean the cap rubber.  "Cap Rubber Cleaning"(P. 198)
	Clean the underside of the carriage.  "Carriage Underside Cleaning"(P. 198)
	Clean the underside of the UV-LED unit.  "Carriage Underside Cleaning"(P. 198)
	Check the waste ink levels in the waste ink tank.  "When "Check Waste Ink Tank" message appears"(P. 242)
Every month	Clean around the cloth wiper.  "Cloth Wiper Area Cleaning"(P. 200)
	Clean the NCU.  "NCU Cleaning"(P. 200)
	Clean the DAS sensor.  "DAS (Automatic Correction Function) Sensor Cleaning"(P. 202)
	Clean the ink discharge channel.  "Ink Discharge Channel Cleaning"(P. 203)
	Clean the media sensor.  "Media Sensor Cleaning"(P. 205)
	Clean the media cutter.  "Media Cutter Cleaning"(P. 206)
	Clean the media holder. "Media Holder Cleaning"(P. 207)
	Clean the jam sensor detecting plate. "Jam Sensor Detecting Plate Cleaning"(P. 208)
	Clean the platen. "Platen Cleaning"(P. 209)
	Clean the cover (exterior). "Cover (Exterior) Cleaning"(P. 209)
	Clean the mist filter. Soak up ink with a paper towel. "Cleaning the Mist Filter"(P. 210)
When not used for more than a week	Clean the cap and wash the ink discharge channels. After cleaning, store without turning off the main power supply.  "When this Printer is Left Unused for a Long Time"(P. 213)

Items Required for Maintenance

To order replacement consumable items, contact your local dealer or our service office. For more information on consumable items, refer to our website (<https://mimaki.com/supply/inkjet.html>).



- Do not store consumable items in locations where children may enter.

Ink Maintenance

If ink constituents are sedimented, the ink density may become uneven. We recommend shaking the ink periodically to keep printing consistent.

● JV/CJV/TS

JV
CJV
TS

Once every three days.

Important!

- **Shake taking care that the ink eco-cases do not become detached** from the ink supply unit. Ink may leak out if the ink eco-cases become detached.

1 Shake the ink eco-cases slowly approximately 10 times.

- Shake the ink eco-cases back and forth while holding the top.

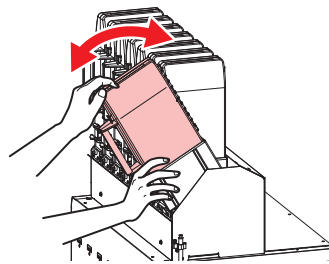

- Be sure to shake the ink eco-case back and forth by holding its top. Ink may leak out if the top is not held and the ink eco-cases become detached.

● UCJV

UCJV

UV ink: once a month.

UV white ink: once a day.



- The UCJV counts the time elapsed after the white ink was stirred. The "Shake White Ink Bottle" message appears when a preset count is reached. If the message appears, shake the white ink by following the instructions below:
Timing when the message appears: Every 24 hours (or when the power is turned on if the power was turned off).

1 Shake the ink bottle to the left and right slowly at least 20 times.

- Tighten the ink bottle lid securely, then shake the bottle slowly from left to right to ensure that the ink moves inside, holding the ink bottle lid with a piece of recommended non-woven fabric.

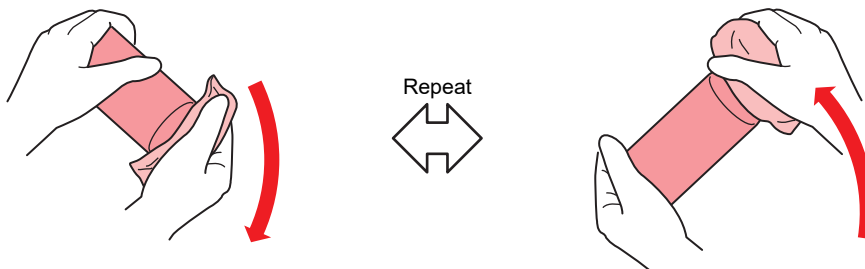



- Shake slowly. If the bottle is shaken too violently, ink may leak out or the air mixed in the ink may cause nozzle clogging.
- If the ink bottle is partially used, tilt it slowly until the ink bottle is upright.

Cap Rubber Cleaning

The cap prevents the print head nozzle surface from drying out. Continuing to use a dirty cap may affect ink take-up and lead to ejection failures (such as nozzle clogging or deflection).



- Be careful to avoid leaving fragments from the cleaning stick behind when cleaning. These fragments will increase the risk of ejection failures (e.g., nozzle clogging or deflection).

- 1 On the LOCAL mode screen, select [MENU] > [Maintenance], then press the [ENTER] key.**
 - The Maintenance menu is displayed.
- 2 Select [Station Maint.] > [Carriage Out] > [Move To Platen Right End], then press the [ENTER] key.**
 - The carriage moves over the platen.
- 3 Open the maintenance cover on the right side.**
- 4 Clean the cap rubber.**
 - Wipe off any ink and dust adhering using a cleaning stick moistened with maintenance liquid. Wipe off the maintenance liquid. Make sure none remains.
 - Clean the areas indicated in red in the diagram (the entire interior and exterior of the cap rubber, the tabs, and the mesh retainers).

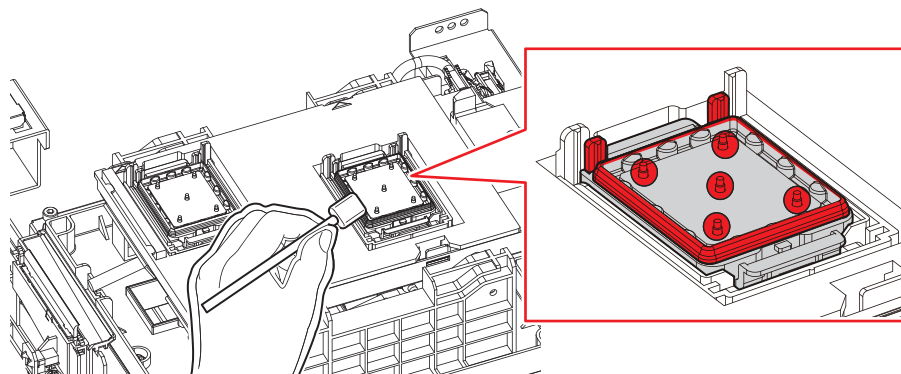

- 5 Close the maintenance cover, then press the [ENTER] key.**

Carriage Underside Cleaning

The underside of the carriage becomes coated with ink wiped off by the wiper. Continuing to use the dirty carriage underside will rub dried ink and attached dust on to the media, resulting in contaminated prints.

The print head uses an extremely delicate mechanism. Take great care when handling it.



- Be careful to avoid leaving fragments from the cleaning stick behind when cleaning. These fragments will increase the risk of ejection failures (e.g., nozzle clogging or deflection).

- 1 On the LOCAL mode screen, select [MENU] > [Maintenance], then press the [ENTER] key.**
 - The Maintenance menu is displayed.

- 2 Select [Station Maint.] > [Carriage Out] > [Move To Maint. Space], then press the [ENTER] key.
 - The carriage moves to the maintenance space.
- 3 Open the maintenance cover on the left side.

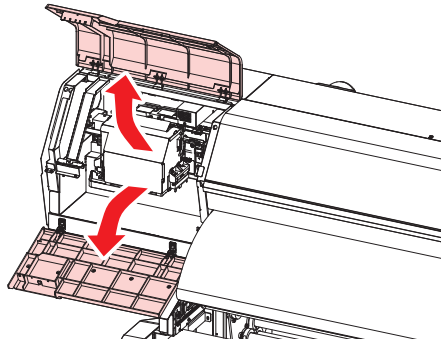

4 (UCJV only) Clean the UV-LED lamp glass surface.

- Wipe off any adhering ink using a cleaning stick moistened with maintenance liquid. Wipe off the maintenance liquid. Make sure none remains.

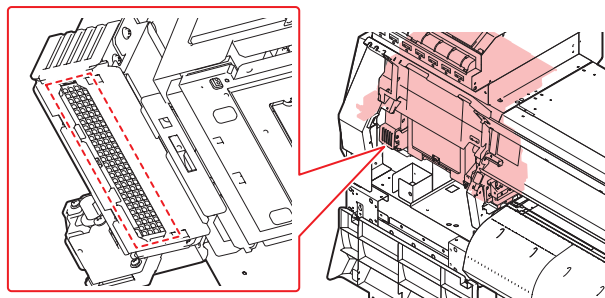

5 Clean around the print head.

- Wipe off any ink and dust adhering using a cleaning stick moistened with maintenance liquid. Wipe off the maintenance liquid. Make sure none remains.

Clean the print head sides and all around the nozzle plate using a cleaning stick.

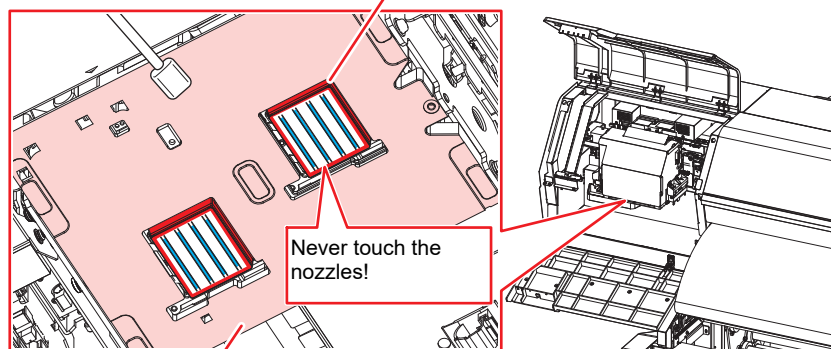

Clean using a cleaning stick or soft cloth.



- Never touch the print head nozzles (areas indicated in blue in the diagram).

- 6 Once cleaning is complete, close the cover, then press the [ENTER] key.

Cloth Wiper Area Cleaning

Continuing to use while dirty will cause dried ink and attached dust around the wiper to rub against the head nozzle surface, and lead to ejection failures (e.g., nozzle clogging or deflection).



- Be careful to avoid leaving fragments from the cleaning stick behind when cleaning. These fragments will increase the risk of ejection failures (e.g., nozzle clogging or deflection).

- 1 On the LOCAL mode screen, select [MENU] > [Maintenance], then press the [ENTER] key.**
 - The Maintenance menu is displayed.
- 2 Select [Station Maint.] > [Carriage Out] > [Move To Platen Right End], then press the [ENTER] key.**
 - The carriage moves over the platen.
- 3 Open the maintenance cover on the right side.**
- 4 Clean the wiper unit cover.**
 - Wipe off any ink and dust adhering using a cleaning stick moistened with maintenance liquid. Wipe off the maintenance liquid. Make sure none remains.

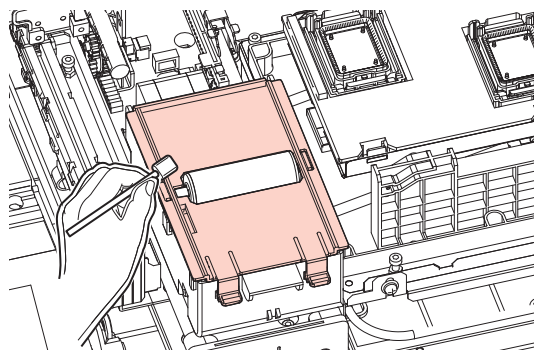

- Be careful to avoid splashing maintenance liquid on the cloth wiper.

- 5 Once cleaning is complete, close the cover, then press the [ENTER] key.**

NCU Cleaning

The NCU uses a sensor to monitor the ink droplets ejected from the print head nozzles. Continuing to use the dirty NCU may prevent the nozzle check function from operating correctly.



- Be careful to avoid leaving fragments from the cleaning stick behind when cleaning. These fragments will increase the risk of ejection failures (e.g., nozzle clogging or deflection).

- 1 On the LOCAL mode screen, select [MENU] > [Maintenance], then press the [ENTER] key.**
 - The Maintenance menu is displayed.
- 2 Select [Station Maint.] > [Carriage Out] > [Move To Platen Right End], then press the [ENTER] key.**
 - The carriage moves over the platen.
- 3 Open the maintenance cover on the right side.**

4 Clean the NCU.

- Wipe off any ink and dust adhering using a cleaning stick moistened with maintenance liquid. Wipe off the maintenance liquid. Make sure none remains.

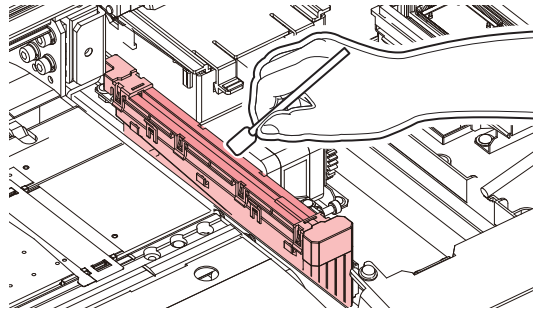

- Insert the cleaning stick as far as the line shown in the illustration.

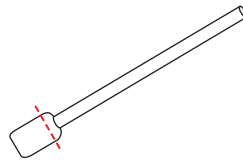

5 Once cleaning is complete, close the cover, then press the [ENTER] key.

DAS (Automatic Correction Function) Sensor Cleaning

The DAS sensor is located on the carriage underside. If dust or debris accumulates on the sensor, DAS (👉 P. 174) may not function.

- 1** On the **LOCAL** mode screen, select **[MENU] > [Maintenance]**, then press the **[ENTER]** key.
 - The Maintenance menu is displayed.
- 2** Select **[Station Maint.] > [Carriage Out] > [Move To Maint. Space]**, then press the **[ENTER]** key.
 - The carriage moves to the maintenance space.
- 3** Open the maintenance cover on the left side.

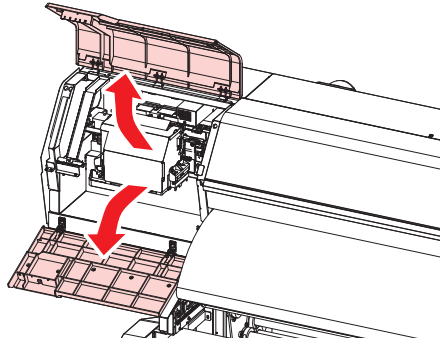

- 4** Clean the DAS sensor.
 - Wipe clean using cotton swabs or a soft cloth.

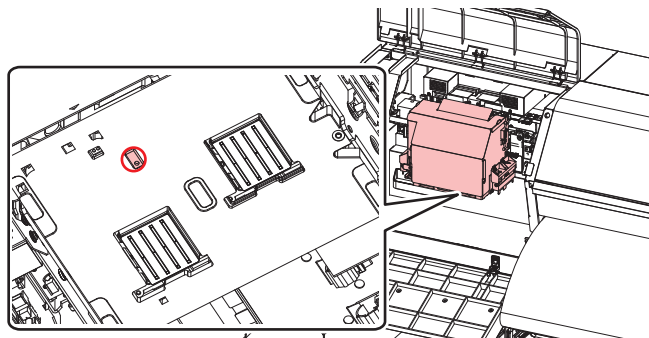

- For heavy soiling, wipe using a soft cloth soaked in diluted neutral detergent and thoroughly wrung out.

- 5** Once cleaning is complete, close the cover, then press the **[ENTER]** key.

Ink Discharge Channel Cleaning

Clean the ink discharge channel regularly to prevent clogging of the ink discharge channel below the cap.

● JV/CJV/TS

JV
CJV
TS

1 On the **LOCAL** mode screen, select **[MENU] > [Maintenance]**, then press the **[ENTER]** key.

- The Maintenance menu is displayed.

2 Select **[Station Maint.] > [Pump tube cleaning]**, then press the **[ENTER]** key.

- The cap is filled with maintenance liquid.



- Close the cover. The cap cannot be filled with maintenance liquid while the cover is open. This is also true if the maintenance liquid cartridge is empty.

3 Open the maintenance cover on the right side.

- Check to confirm that approximately half a capful of maintenance liquid remains.



- If not, use a syringe to draw up some maintenance liquid and drip in approximately half a capful.

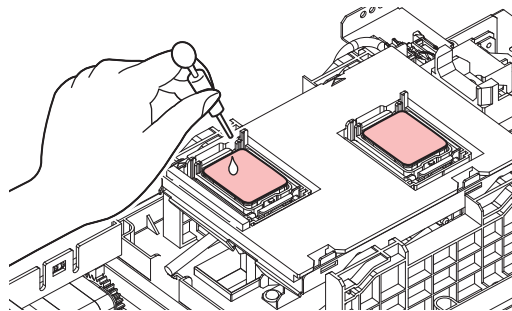

4 Close the maintenance cover, then press the **[ENTER]** key.

- Pump tube (ink discharge channel below the cap) washing starts.

● UCJV

UCJV

1 On the **LOCAL** mode screen, select **[MENU] > [Maintenance]**, then press the **[ENTER]** key.

- The Maintenance menu is displayed.

2 Select **[Station Maint.] > [Pump tube cleaning]**, then press the **[ENTER]** key.

- The carriage moves over the platen.
- "Fill the Liquid. Exit Next [ENT]" appears on the display.

3 Open the maintenance cover on the right side.

4 Check to confirm that approximately half a capful of maintenance liquid remains.

- Use a syringe to draw up some maintenance liquid and drip in approximately half a capful.

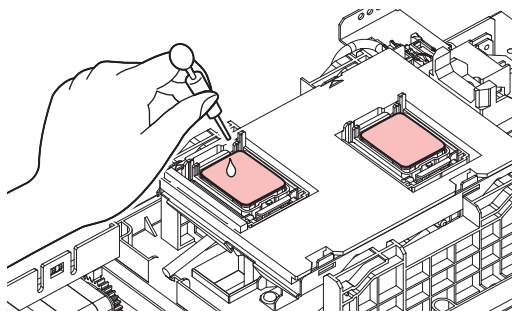

5 Close the maintenance cover, then press the [ENTER] key.

- Pump tube (ink discharge channel below the cap) washing starts.

Media Sensor Cleaning

Media sensors are located on the rear cover and carriage underside. The media cannot be detected correctly if dust or debris accumulates on the sensors. Remove any debris using cotton swabs or a soft cloth.

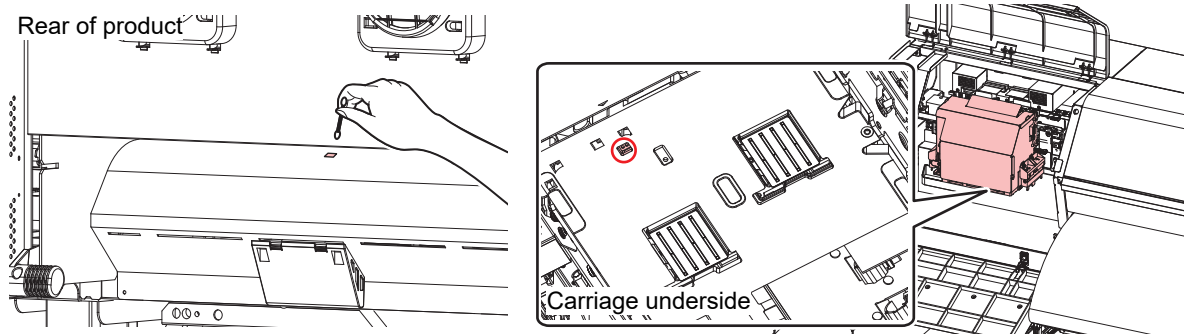

● Cleaning the carriage underside sensor

- 1** On the LOCAL mode screen, select [MENU] > [Maintenance], then press the [ENTER] key.
 - The Maintenance menu is displayed.
- 2** Select [Station Maint.] > [Carriage Out] > [Move To Maint. Space], then press the [ENTER] key.
 - The carriage moves to the maintenance space.
- 3** Open the maintenance cover on the left side.

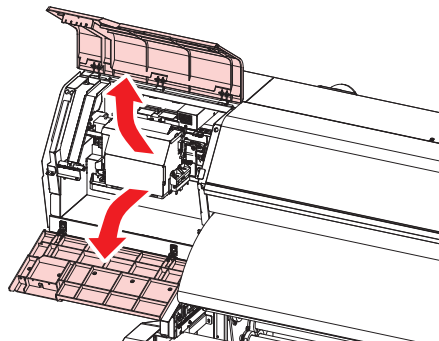

- 4** Clean the media sensor.
- 5** Once cleaning is complete, close the cover, then press the [ENTER] key.

Media Cutter Cleaning

Continuing to use a dirty media cutter may cause dust to collect on the head nozzle surface or the cutter blade to grow dull.



- Avoid touching the cutter blade. Failure to do so may result in injury.

1 On the LOCAL mode screen, select [MENU] > [Maintenance], then press the [ENTER] key.

- The Maintenance menu is displayed.

2 Select [Station Maint.] > [Carriage Out] > [Move To Platen Right End], then press the [ENTER] key.

- The carriage moves over the platen.

3 Open the front cover.



- The carriage can be moved by hand. Move the carriage slowly to a position allowing easy access while working.

4 Remove the media cutter.

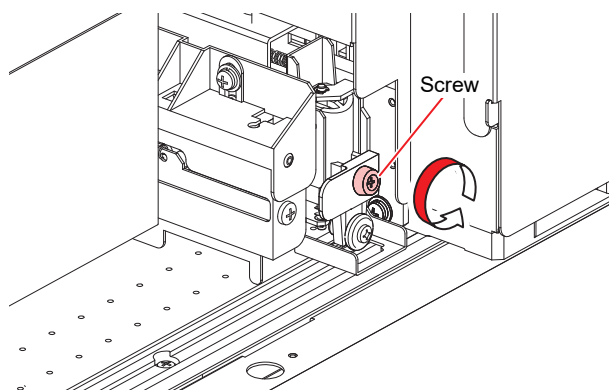

5 Clean both sides of the media cutter.

- Wipe off any adhesive paste, ink and dust adhering using a cleaning stick moistened with industrial alcohol. Wipe off any industrial alcohol so that none remains.

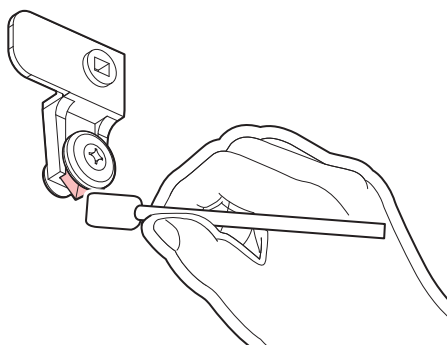

6 Return the media cutter to its original position.



- Tighten the screw securely. A loose screw may cause cutter or platen damage.

7 Check the position of the media cutter.

- Lift up the media cutter by hand if it has dropped down.

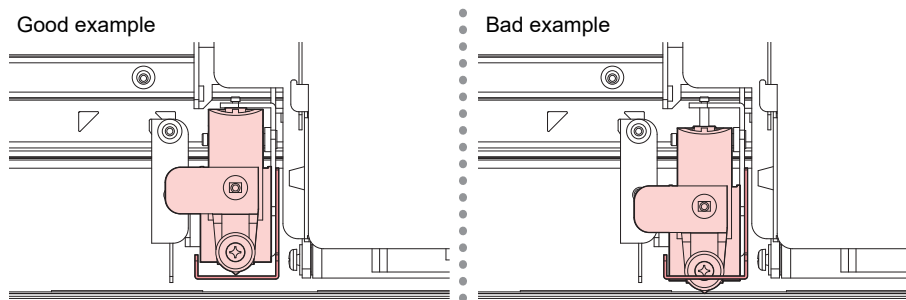

8 Once cleaning is complete, close the cover, then press the [ENTER] key.

Media Holder Cleaning

Continuing to use the dirty platen will prevent proper feeding of the media. It will also cause dried ink and attached dust to rub against the head nozzle surface and lead to ejection failures (e.g., nozzle clogging or deflection).

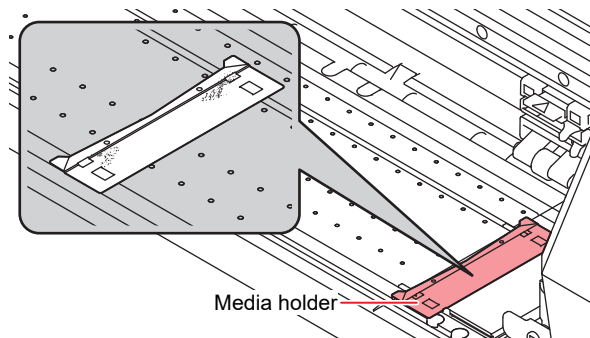

- Turn off the main power supply and unplug the power cable before carrying out maintenance.



- Be careful to prevent liquids from getting inside the machine. Otherwise there is a risk of failure, electric shock, or fire.



- For heavy soiling, wipe using a soft cloth soaked in diluted neutral detergent and thoroughly wrung out.

Jam Sensor Detecting Plate Cleaning

Continuing to use the dirty carriage underside will rub dried ink and attached dust on to the media, resulting in contaminated prints.

- 1** On the **LOCAL** mode screen, select **[MENU] > [Maintenance]**, then press the **[ENTER]** key.
 - The Maintenance menu is displayed.
- 2** Select **[Station Maint.] > [Carriage Out] > [Move To Maint. Space]**, then press the **[ENTER]** key.
 - The carriage moves to the maintenance space.
- 3** Open the maintenance cover on the left side.

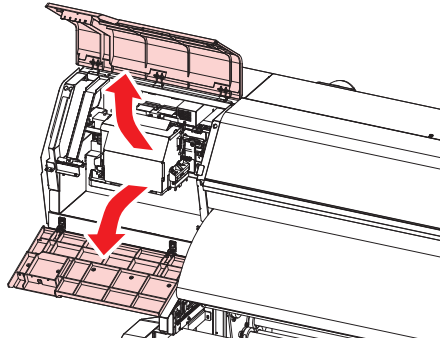

- 4** Clean the jam sensor detecting plate.
 - Clean the jam sensor detecting plate underside at the left and right sides of the carriage.
 - Wipe off any ink and dust adhering using a cleaning stick moistened with maintenance liquid. Wipe off the maintenance liquid. Make sure none remains.

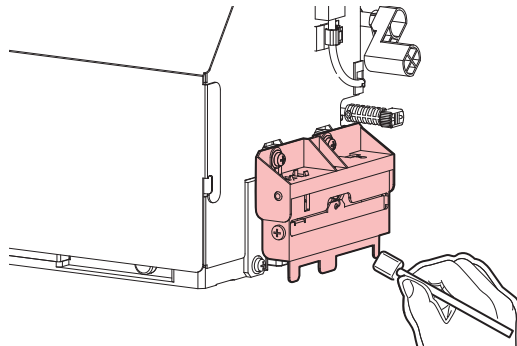

- 5** Once cleaning is complete, close the cover, then press the **[ENTER]** key.

Platen Cleaning

Continuing to use the dirty platen will prevent proper feeding of the media. It will also cause dried ink and attached dust to rub against the head nozzle surface and lead to ejection failures (e.g., nozzle clogging or deflection).

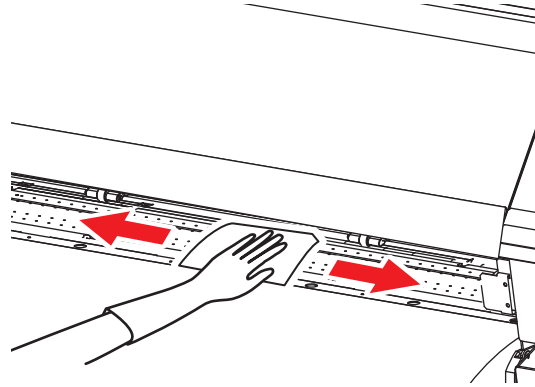

- Turn off the main power supply and unplug the power cable before carrying out maintenance.



- Be careful to prevent liquids from getting inside the machine. Otherwise there is a risk of failure, electric shock, or fire.



- The grooves in which the media holder slides and the media is cut are susceptible to dust accumulation. Remove any debris carefully.



- For heavy soiling, wipe using a soft cloth soaked in diluted neutral detergent and thoroughly wrung out.

Cover (Exterior) Cleaning

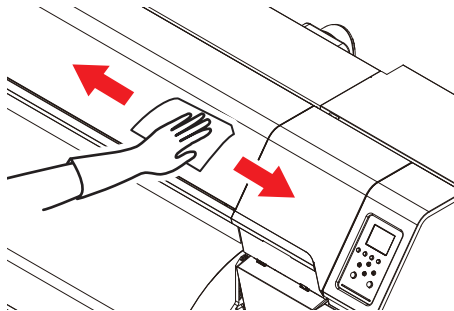

- Be careful to prevent liquids from getting inside the machine. Otherwise there is a risk of failure, electric shock, or fire.



- For heavy soiling, wipe using a soft cloth soaked in diluted neutral detergent and thoroughly wrung out.

Cleaning the Mist Filter

UCJV



- The description here applies to the UCJV.

The mist filter absorbs the mist generated when ink droplets are discharged from the print head. Continuing to use it when it is dirty will result in contaminated prints.

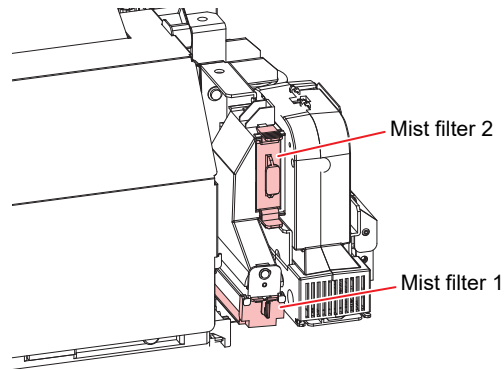

- 1** On the LOCAL mode screen, select [MENU] > [Maintenance], then press the [ENTER] key.
 - The Maintenance menu is displayed.
- 2** Select [Station Maint.] > [Carriage Out] > [Move To Maint. Space], then press the [ENTER] key.
 - The carriage moves to the maintenance space.
- 3** Open the maintenance cover on the left side.

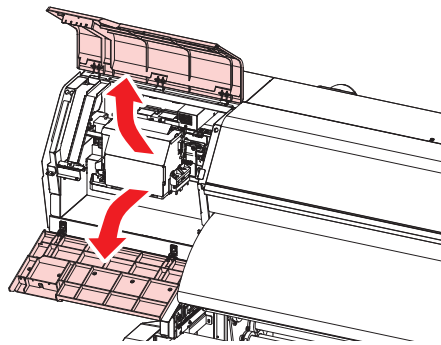

4 Remove the mist filter.

- To remove the mist filter, pull the knob to the front while pushing the tab in the direction indicated by the arrow.

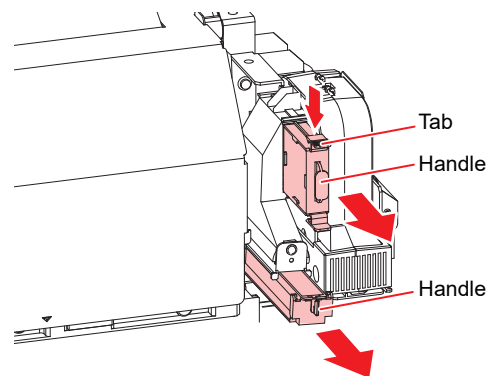

5 Clean the filter.

- Remove the filter and press down on it with a paper towel to remove dirt.
- Wipe off the dirt adhering to the filter case.



- Replace the mist filter if it gets very dirty—for example, due to liquefaction of ink adhering to the filter.

 ["Mist Filter Replacement"\(P. 245\)](#)

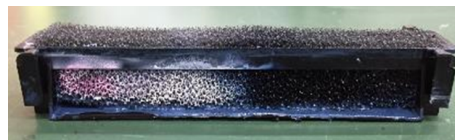

6 Reinstall the mist filter in its original position.

7 Once cleaning is complete, close the cover, then press the [ENTER] key.

Blowing Fan Filter Cleaning

TS



- The description here applies to the TS.

Wash the blowing fan filter in water if it is dirty.

● Recommended cleaning guide

Important!

- Check the filter for dirt every two weeks, and wash.
- Replace the filter every three months.  ["Blowing Fan Filter Replacement"\(P. 230\)](#)



- Turn off the main power and unplug the power cable before replacement.

1 Remove the fan filter cover.

- Push the fan filter cover claw outward, and pull the cover to the front.

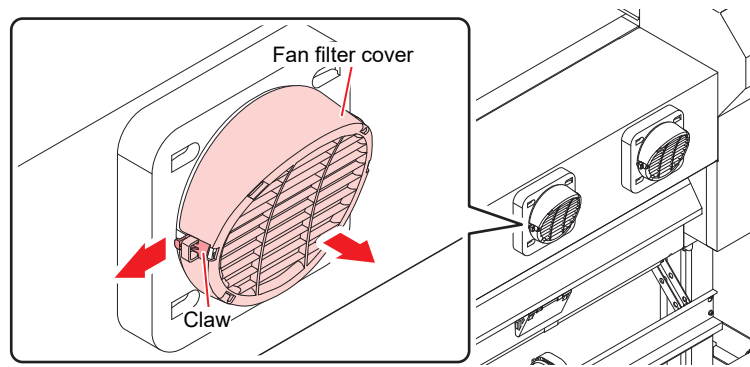

2 Remove the filter.

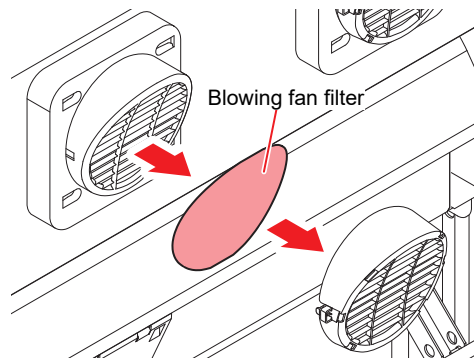

3 Wash the filter.



- Dry the filter after washing.

4 Attach the dry filter together with the fan filter cover.

- Push in the fan filter cover until the tab clicks.

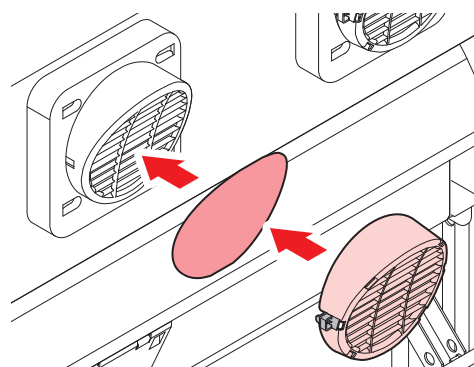

When this Printer is Left Unused for a Long Time

Clean as follows if the product is not used for one week or longer:

Check beforehand

Is [Near End] or [Ink End] displayed?

- Maintenance liquid and ink is aspirated during the washing operation. Washing is not possible if an error occurs during this process. Replace with new ink.



- Do not turn off the main power supply. Turning off the main power supply will disable the automatic maintenance function (including nozzle clogging prevention function and ink discharge channel cleaning function). This increases the risk of ejection failures (such as nozzle clogging or deflection).

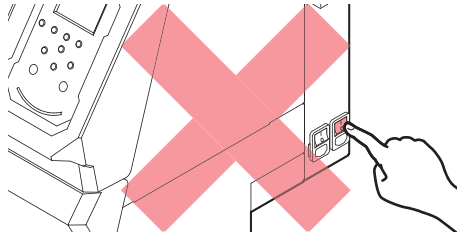

- Do not leave media loaded on the platen. This may leave irregularities or ripples in the media.



When the machine is not in use, raise the clamp lever to separate the pinch rollers from the grit rollers.

- Leaving the pinch rollers lowered may cause them to become deformed and prevent media from being fed correctly.
- Leaving media loaded will subject it to force from the pinch rollers, which may leave pinch roller marks on it.



- Perform the following if the "Check Waste Ink Tank" message appears on the display.
 ["Waste Ink Tank Replacement"\(P. 242\)](#)

JV/CJV/TS

JV
CJV
TS

- 1 On the LOCAL mode screen, select [MENU] > [Maintenance], then press the [ENTER] key.
 - The Maintenance menu is displayed.
- 2 Select [Station Maint.] > [Custody Wash], then press the [ENTER] key.
 - The carriage moves over the platen.
- 3 Open the maintenance cover on the right side.
- 4 Clean the cap rubber.
 -  ["Cap Rubber Cleaning"\(P. 198\)](#)
- 5 Once cleaning is complete, close the cover, then press the [ENTER] key.
 - The cap is filled with maintenance liquid.



- Close the cover. The cap cannot be filled with maintenance liquid while the cover is open. This is also true if the maintenance liquid cartridge is empty.

6 Open the maintenance cover on the right side.

- Check to confirm that the cap is filled with maintenance liquid.



- If not, use a syringe to draw up some maintenance liquid and fill until it almost overflows from the cap.

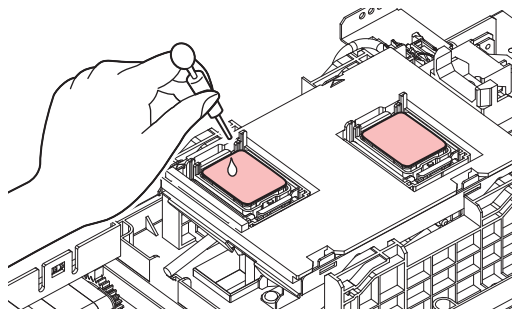

7 Close the maintenance covers.

8 Set the exposure time, then press the [ENTER] key.

- Cleaning is performed automatically once print nozzle washing has ended.
- The cap is filled with maintenance liquid.

9 Open the maintenance cover on the right side.

- Check to confirm that the cap is filled with maintenance liquid.



- If not, use a syringe to draw up some maintenance liquid and fill until it almost overflows from the cap.

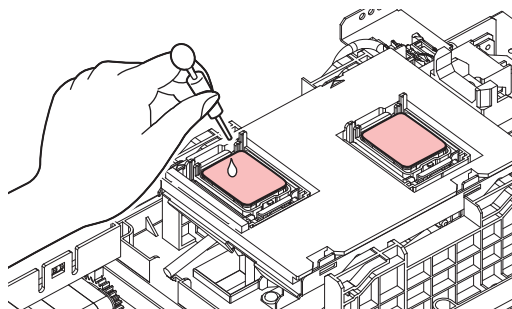

10 Close the maintenance cover, then press the [ENTER] key.

- Pump tube (ink discharge channel below the cap) washing starts.

UCJV

UCJV

- 1** On the LOCAL mode screen, select [MENU] > [Maintenance], then press the [ENTER] key.
 - The Maintenance menu is displayed.
- 2** Select [Station Maint.] > [Custody Wash], then press the [ENTER] key.
 - The carriage moves over the platen.
- 3** Open the maintenance cover on the right side.
- 4** Clean the cap rubber.
 -  ["Cap Rubber Cleaning"\(P. 198\)](#)
- 5** Once cleaning is complete, close the cover, then press the [ENTER] key.
 - "Fill the Liquid. Exit Next [ENT]" appears on the display.
- 6** Fill the cap with maintenance liquid.
 - Use a syringe to draw up some maintenance liquid and fill until it almost overflows from the cap.

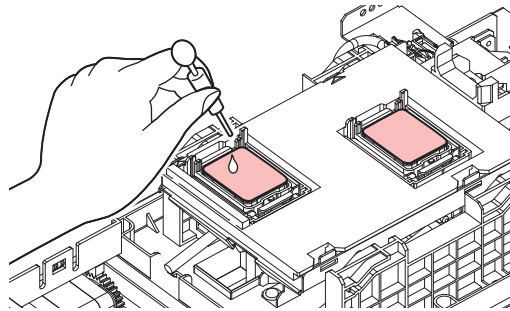

- 7** Close the maintenance cover, then press the [ENTER] key.
- 8** Set the exposure time, then press the [ENTER] key.
 - Cleaning is performed automatically once print nozzle washing has ended.
 - "Fill the Liquid. Exit Next [ENT]" appears on the display.
- 9** Open the maintenance cover on the right side.
- 10** Fill the cap with maintenance liquid.
 - Use a syringe to draw up some maintenance liquid and fill until it almost overflows from the cap.

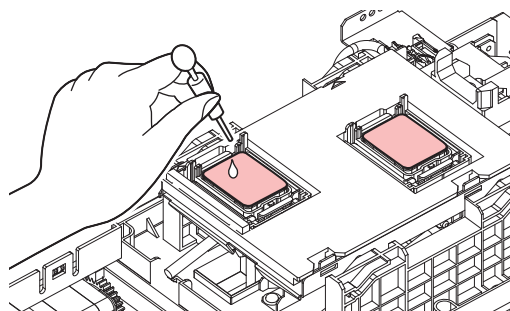

11 Close the maintenance cover, then press the [ENTER] key.

- Pump tube (ink discharge channel below the cap) washing starts.

7.3 Replacement of Consumable Item

To order replacement consumable items, contact your local dealer or our service office. For more information on consumable items, refer to our website (<https://mimaki.com/supply/inkjet.html>).



- Do not store consumable items in locations where children may enter.



- When disposing of consumable items, contact an industrial waste disposal operator or dispose of the product in accordance with the local laws and regulations.



Consumable Item Replacement Timing

● JV

Timing	Item
When run out	"Cloth Wiper Replacement"(P. 219)
When dirty	"Replacing the Absorber Around the Station"(P. 225) "Exhaust Fan Filter Replacement"(P. 229) "Blowing Fan Filter Replacement"(P. 230)
When ejection failures cannot be remedied	"Cap Replacement"(P. 223)
When damaged	"Cap Replacement"(P. 223) "Pinch Roller Replacement"(P. 231) "Media Holder Replacement"(P. 232) "Media Cutter Replacement"(P. 234) "Y Cutter Replacement (XY Slitter)"(P. 236) "X Cutter Replacement (XY Slitter)"(P. 237) "Media Edge Guide Film Replacement"(P. 239) (option)
When replacing ink	"Ink Supply Unit Ink Absorber Replacement"(P. 240)
When "Check Waste Ink Tank" appears on the display	"Waste Ink Tank Replacement"(P. 242)

● CJV

















Timing	Item
When run out	"Cloth Wiper Replacement"(P. 219)
When dirty	"Replacing the Absorber Around the Station"(P. 225) "Exhaust Fan Filter Replacement"(P. 229) "Blowing Fan Filter Replacement"(P. 230)
When ejection failures cannot be remedied	"Cap Replacement"(P. 223)
When damaged	"Cap Replacement"(P. 223) "Pinch Roller Replacement"(P. 231) "Media Holder Replacement"(P. 232) "Media Cutter Replacement"(P. 234) "Y Cutter Replacement (XY Slitter)"(P. 236) "X Cutter Replacement (XY Slitter)"(P. 237) "Media Edge Guide Film Replacement"(P. 239) (option) "Cutter for Cutting Machine"(P. 247)

Timing	Item
	 "Pen Line Replacement"(P. 247)
When replacing ink	 "Ink Supply Unit Ink Absorber Replacement"(P. 240)
When "Check Waste Ink Tank" appears on the display	 "Waste Ink Tank Replacement"(P. 242)

● TS

Timing	Item
When run out	 "Cloth Wiper Replacement"(P. 219)
When dirty	 "Replacing the Absorber Around the Station"(P. 225)  "Exhaust Fan Filter Replacement"(P. 229)  "Blowing Fan Filter Replacement"(P. 230)
When ejection failures cannot be remedied	 "Cap Replacement"(P. 223)
When damaged	 "Cap Replacement"(P. 223)  "Pinch Roller Replacement"(P. 231)  "Media Holder Replacement"(P. 232)  "Media Cutter Replacement"(P. 234)  "Media Edge Guide Film Replacement"(P. 239)
When replacing ink	 "Ink Supply Unit Ink Absorber Replacement"(P. 240)
When "Check Waste Ink Tank" appears on the display	 "Waste Ink Tank Replacement"(P. 242)

● UCJV







Timing	Item
When run out	 "Cloth Wiper Replacement"(P. 219)
When dirty	 "Replacing the Absorber Around the Station"(P. 225)  "Exhaust Fan Filter Replacement"(P. 229)  "Mist Filter Replacement"(P. 245)  "UV-LED Glass Replacement"(P. 246)
When ejection failures cannot be remedied	 "Cap Replacement"(P. 223)
When damaged	 "Cap Replacement"(P. 223)  "Pinch Roller Replacement"(P. 231)  "Media Holder Replacement"(P. 232)  "Media Cutter Replacement"(P. 234)  "Y Cutter Replacement (XY Slitter)"(P. 236) (option)  "X Cutter Replacement (XY Slitter)"(P. 237) (option)  "Media Edge Guide Film Replacement"(P. 239) (option)  "Cutter for Cutting Machine"(P. 247)  "Pen Line Replacement"(P. 247)
When "Check Waste Ink Tank" appears on the display	 "Waste Ink Tank Replacement"(P. 242)
Periodically	 "Bottle Cap Replacement"(P. 248)

Cloth Wiper Replacement

Replace cloth wipers with new ones when they have run out.



- **The cloth wipers to use depend on the model.** Using inappropriate cloth wipers may damage the print head.

Model	JV/CJV/UCJV	TS (Sb ink)	TS (TP ink)
Code/ Package type	 <p>Seal (red)</p>		 <p>Seal (blue)</p>
	 <p>SPC-0919/Aluminum pack</p>	 <p>SPC-0905/Plastic bag</p>	 <p>SPC-0932/Aluminum pack</p>



SPC-0919 and SPC-0932 cloth wipers

- Precautions are included with the cloth wipers. Thoroughly read them and make sure you understand the contents.
- When disposing of cloth wipers, **be sure to place them in a sealed bag.** Contact an industrial waste disposal operator or dispose of in accordance with the local laws and regulations.
- When handling cloth wipers, ensure adequate ventilation and take care not to inhale the solvent fumes.



- When handling **SPC-0919 or SPC-0932 cloth wipers**, be sure to wear safety glasses, gloves, and a mask. There is a risk of the liquid (solvent) contained in cloth wipers splashing and contacting your skin, eyes, or mouth.



- 1 "Wiper End" appears on the display.
- 2 On the LOCAL mode screen, select [MENU] > [Maintenance], then press the [ENTER] key.
 - The Maintenance menu is displayed.
- 3 Select [Station Maint.] > [Replace Wiper], then press the [ENTER] key.
 - The carriage moves over the platen.
- 4 Open the maintenance cover on the right side.

5 Open the cloth wiper cover.

- Push the two tabs at the front up to open.

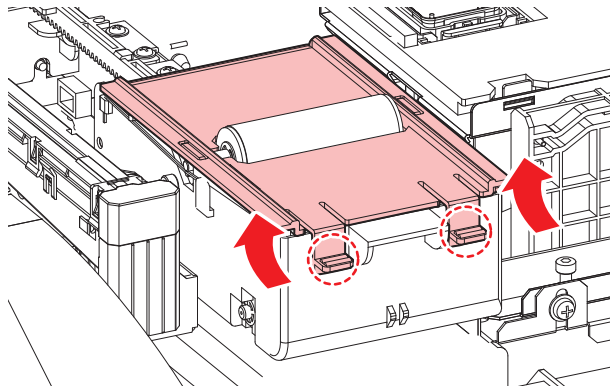

6 Remove the wiper together with the spindle.

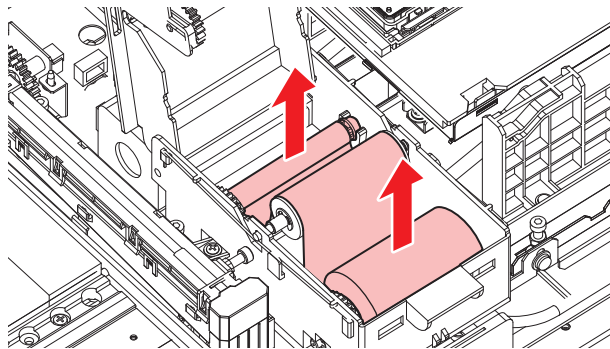

7 Remove the wiper from the spindle.



- When disposing of ink, maintenance liquid or other liquid used with the product, or containers or non-woven fabric contaminated with ink or other liquid, contact an industrial waste disposal operator or dispose of the product in accordance with the local laws and regulations.

8 Clean the wiper unit underside.

- Wipe off any ink and dust adhering using a cleaning stick moistened with maintenance liquid. Wipe off the maintenance liquid. Make sure none remains.

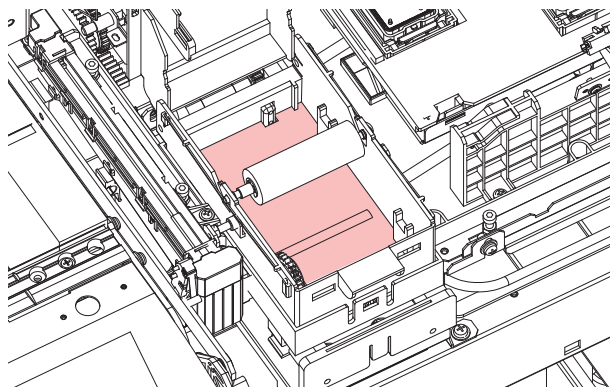

9 Clean the wipe roller.

- Wipe off any ink and dust adhering using a cleaning stick moistened with maintenance liquid. Wipe off the maintenance liquid. Make sure none remains.

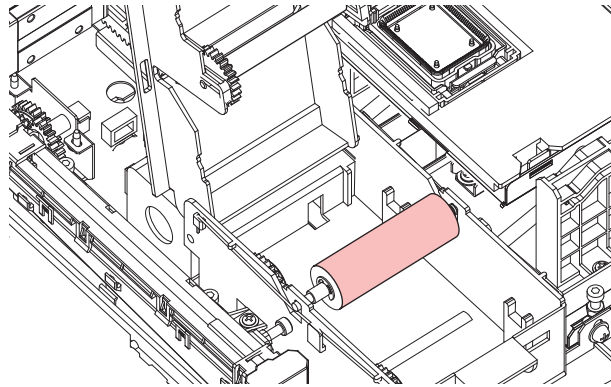

10 Clean the pinch rollers.

- Gently wipe off any dust adhering with a soft cloth.

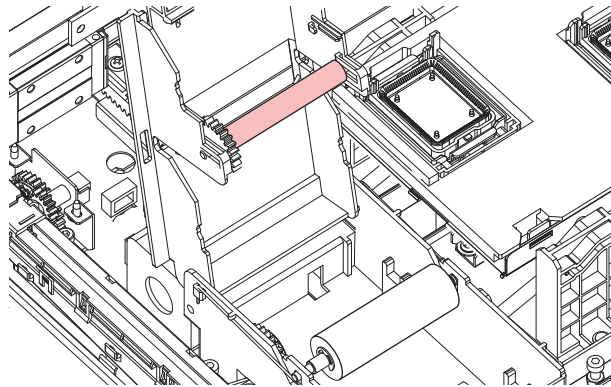

- Do not wipe too hard. Wiping too hard may degrade the sponge.

11 Mount a new cloth wiper.

- (1) Remove the cloth wiper from the bag.
- (2) Unroll the side with more cloth on it.

[When removed from bag]

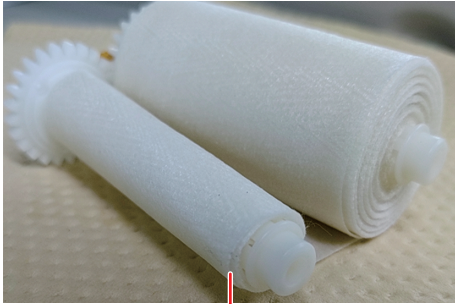

Wound approximately three times

[When mounted in the wiper unit]

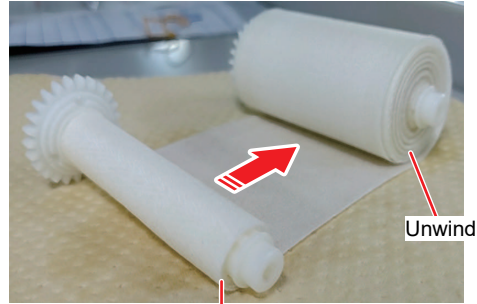

Do not unwind!

- (3) Mount a new cloth wiper.

- Mount the cloth wiper with the gear on the left.

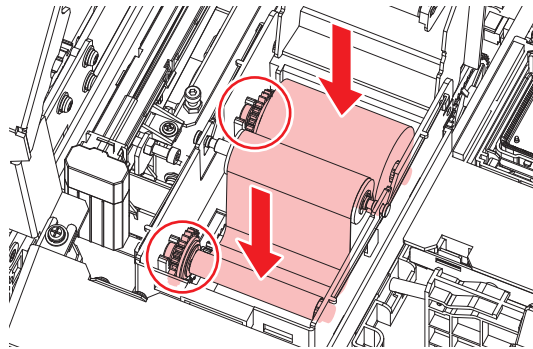

Important!

- If no cloth is wound around the spindle, wind the cloth around the spindle three times before mounting. If the cloth is mounted with no cloth wound around the spindle, the cloth may become detached from the wiper unit.

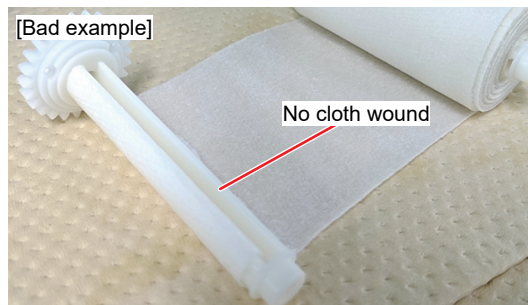

12 Close the cloth wiper cover.

13 Close the maintenance cover, then press the [ENTER] key.

- The remaining amount of cloth wiper is reset.

Cap Replacement

If ejection failures (e.g., nozzle clogging or deflection) remain unresolved even after cleaning, replace with a new cap.



- Be sure to replace the cap if you observe any scratches or other damage on the rim.

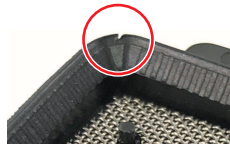

- When using Sb or TP ink for extended periods, the cap surface is susceptible to drying out, which can lead to path clogging. If this occurs, either replace the cap or remove and wash it.



- We recommend replacing the cap every six to twelve months.
(TP ink: every six months, other ink: every twelve months)

- 1 On the LOCAL mode screen, select [MENU] > [Maintenance], then press the [ENTER] key.**
 - The Maintenance menu is displayed.
- 2 Select [Station Maint.] > [Replace Cap], then press the [ENTER] key.**
 - The carriage moves over the platen.
- 3 Open the maintenance cover on the right side.**
- 4 Remove the cap.**
 - Squeeze the lugs on either side of the cap and pull off.

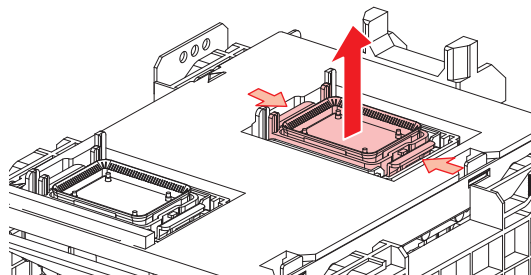

- 5 [When using Sb ink and TP ink] Rinse the cap with the mesh side facing downward in a container filled with maintenance liquid. Remove, then wipe clean the resin part thoroughly.**

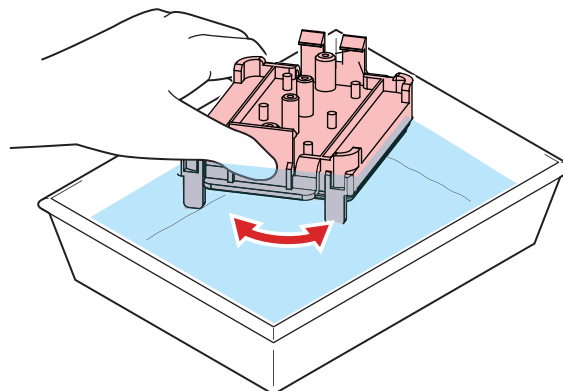

6 Apply maintenance liquid.

- Use a syringe to apply two or three drops of maintenance liquid to the hole at the front.

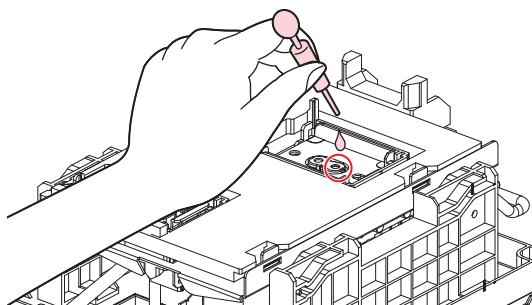

7 Mount a new cap.

- Position with the slot at the front and push in until it clicks.

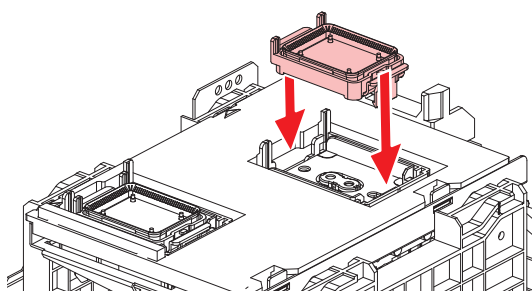

8 Once replacement is complete, close the cover, then press the [ENTER] key.

Replacing the Absorber Around the Station

If the cap absorber or maintenance liquid absorber is very dirty or if ink drips on to the media, replace with a new cap absorber.



- UCJV: Maintenance liquid absorber not included.

With Resin Plate

- 1 On the LOCAL mode screen, select [MENU] > [Maintenance], then press the [ENTER] key.
 - The Maintenance menu is displayed.
- 2 Select [Station Maint.] > [Carriage Out] > [Move To Platen Right End], then press the [ENTER] key.
 - The carriage moves over the platen.
- 3 Open the maintenance cover on the right side.
- 4 Remove the cap absorber together with the plate.
 - Push up the two tabs at the front to remove the cap absorber.

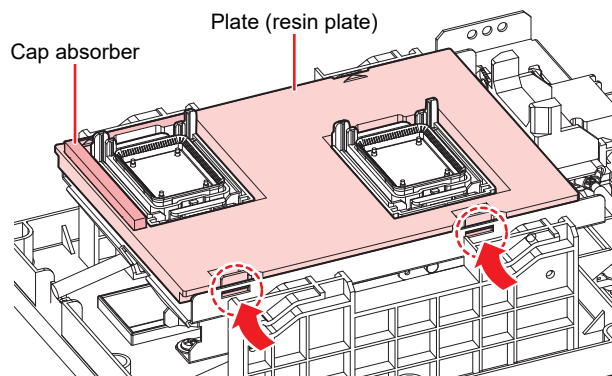

- Avoid ink dripping when removing the cap absorber.

- 5 Clean the cap base.

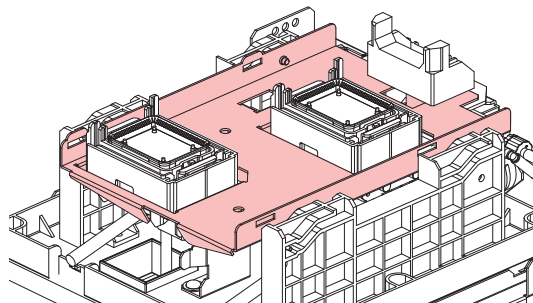

6 Mount a new cap absorber (with plate).

- Push the tabs on the cap absorber into the slits at the rear of the C slider, and clip in the tabs at the front.

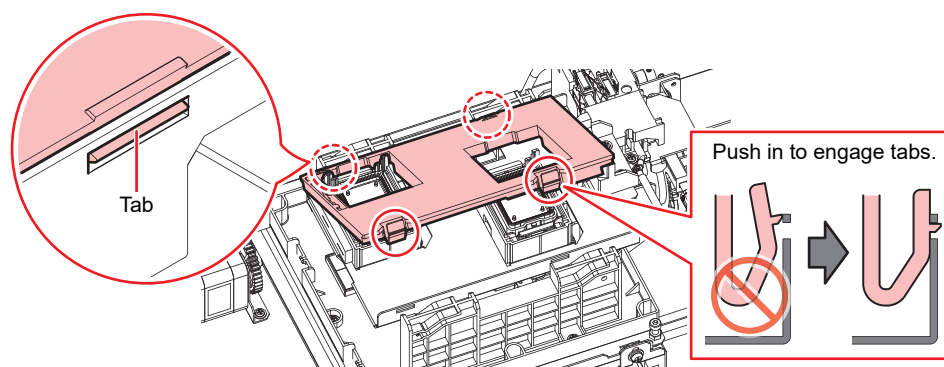

7 Remove the maintenance liquid absorber.

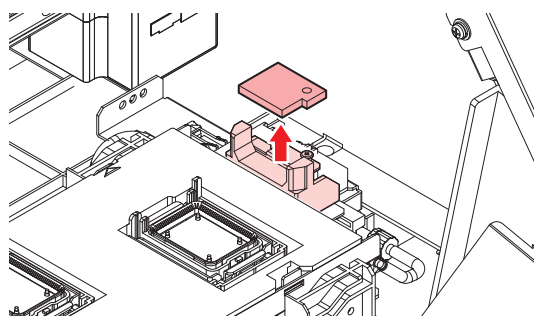

8 Wipe away any maintenance liquid from around the slider block.

9 Mount a new maintenance liquid absorber.

- Push firmly on to the protrusion.

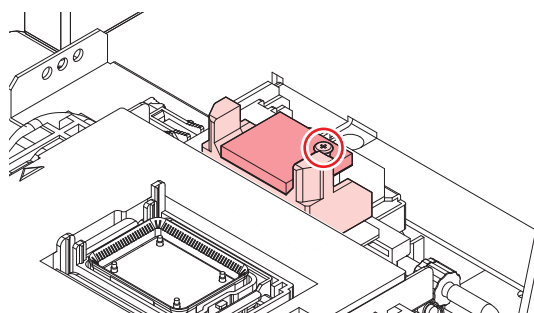

10 Check to confirm that the absorber is not lifting or curved.

11 Once replacement is complete, close the cover, then press the [ENTER] key.

With Metal Plate

1 On the LOCAL mode screen, select [MENU] > [Maintenance], then press the [ENTER] key.

- The Maintenance menu is displayed.

2 Select [Station Maint.] > [Carriage Out] > [Move To Platen Right End], then press the [ENTER] key.

- The carriage moves over the platen.

3 Open the maintenance cover on the right side.

4 Remove the cap absorber.

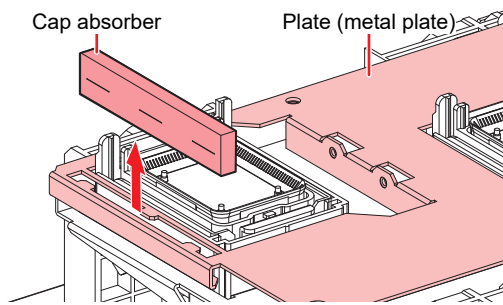

- Avoid ink dripping when removing the cap absorber.

5 Mount a new cap absorber.

- Insert the tabs on the plate into the slits in the cap absorber.

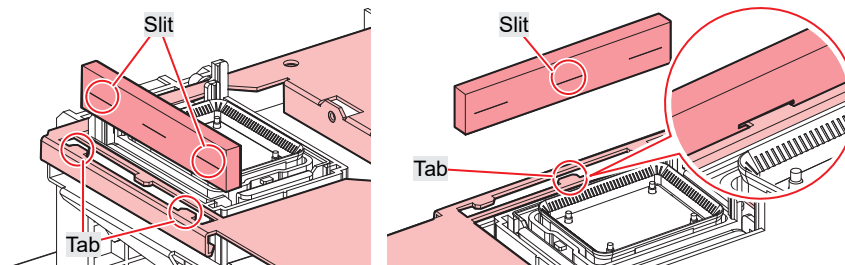

- Check to confirm that the cap absorber does not become detached.

6 Remove the maintenance liquid absorber.

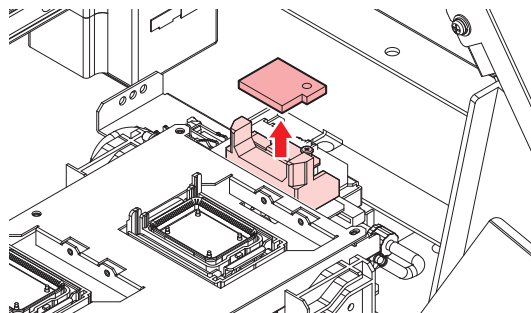

7 Wipe away any maintenance liquid from around the slider block.

8 Mount a new maintenance liquid absorber.

- Push firmly on to the protrusion.

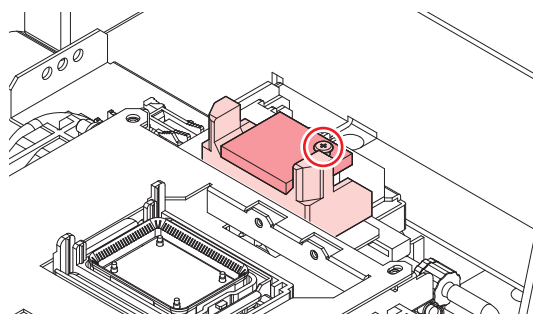

9 Check to confirm that the absorber is not lifting or curved.

10 Once replacement is complete, close the cover, then press the [ENTER] key.

Exhaust Fan Filter Replacement

Check the exhaust fan filter condition. Replace if very dirty.

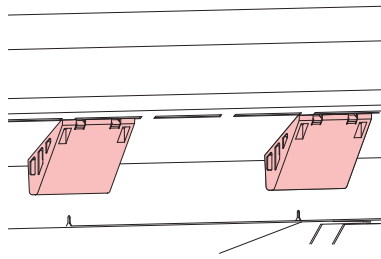

1 Remove the exhaust fan box.

- Push the tabs at the front to remove the exhaust fan box.

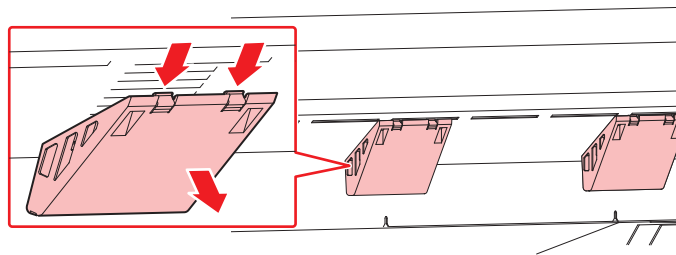

- Replace the very dirty exhaust fan box with new one.

2 Mount a new exhaust fan filter in the exhaust fan box.

- Press the exhaust fan filter into the space under the tabs of the exhaust fan box.

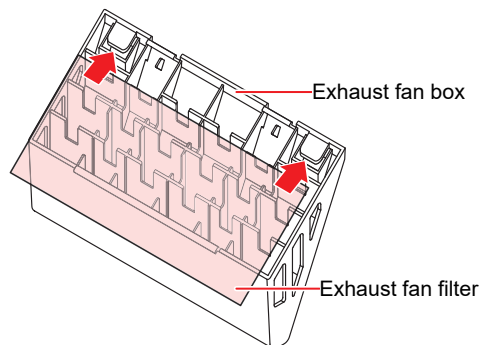

3 Mount the exhaust fan box.

- Insert the tabs of the exhaust fan box into the slits of the machine, and clip in the tabs at the front.

Blowing Fan Filter Replacement

JV

CJV

TS



- The description here applies to the JV/CJV/TS.

Replace the blowing fan filter if it is dirty.

Important!

If sublimation transfer ink is used

- Replace the filter every three months.



- Turn off the main power and unplug the power cable before replacement.

1 Remove the fan filter cover.

- Push the fan filter cover claw outward, and pull the cover to the front.

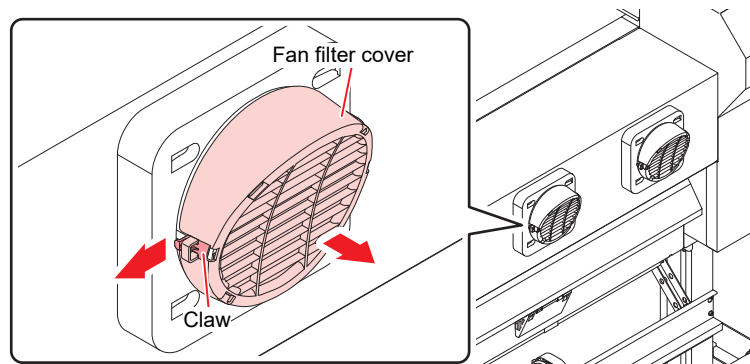

2 Remove the filter.

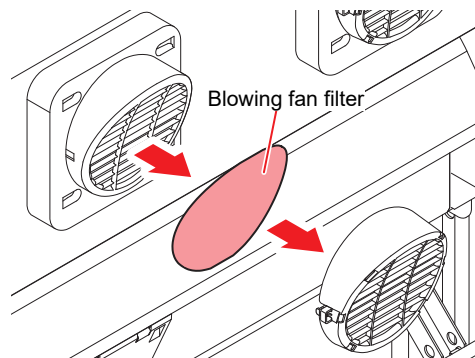

3 Mount a new filter and the fan filter cover.

- Push in the fan filter cover until the tab clicks.

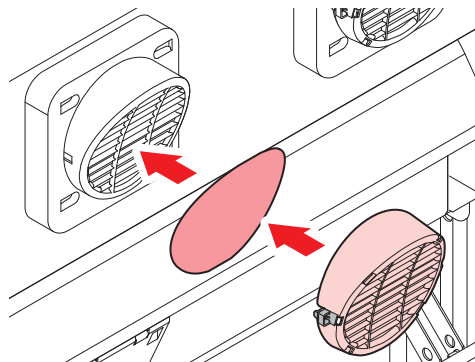

Pinch Roller Replacement

Replace worn or dirty pinch rollers with new ones.

Important! If sublimation transfer ink is used

- Replace the pinch rollers every month if used for approximately 12 hours per day.
- Replace the pinch rollers every two weeks if used 24 hours per day.



- Turn off the main power and unplug the power cable before replacement.

- 1 Open the front cover.
- 2 Raise the clamp lever.
- 3 Remove the O-ring retaining the pinch rollers.

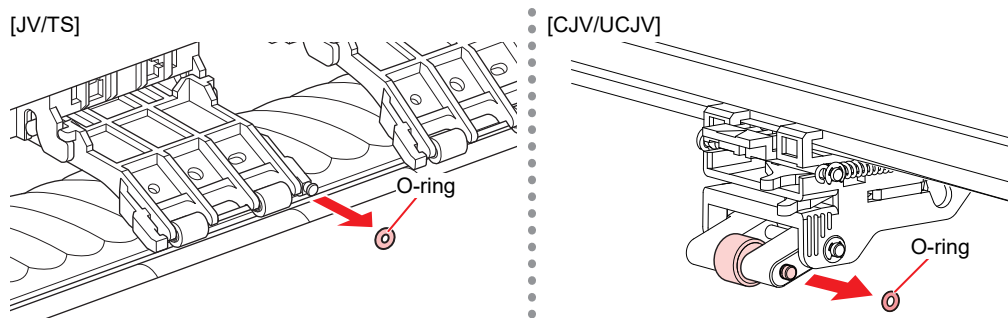

- The pinch rollers are small. Be careful to avoid dropping them into the product interior.

- 4 Remove the pinch rollers or the pinch roller spindle.

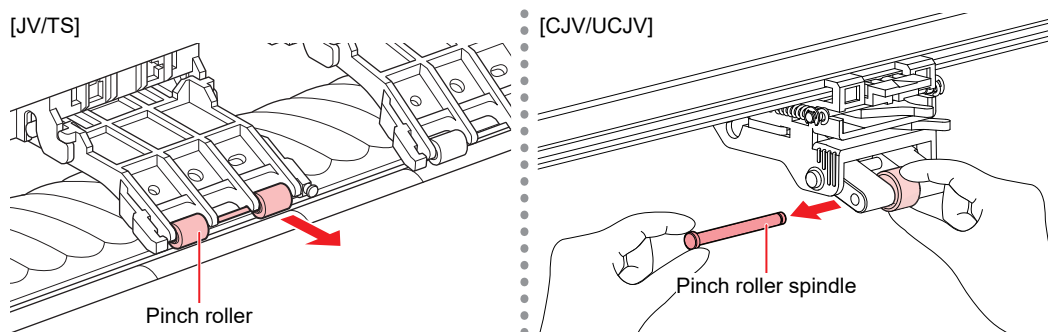

- 5 Mount new pinch rollers, and secure them using the O-ring.
- 6 Close the front cover.

Media Holder Replacement

If the media holder becomes deformed and touches the carriage or print head, replace with a new media holder.



- Turn off the main power and unplug the power cable before replacement.

1 Open the maintenance cover on the left side.

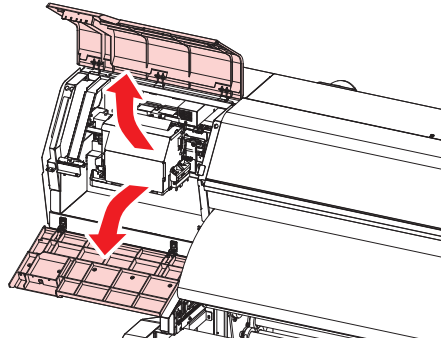

2 Remove the side screw, and detach the media holder stopper.

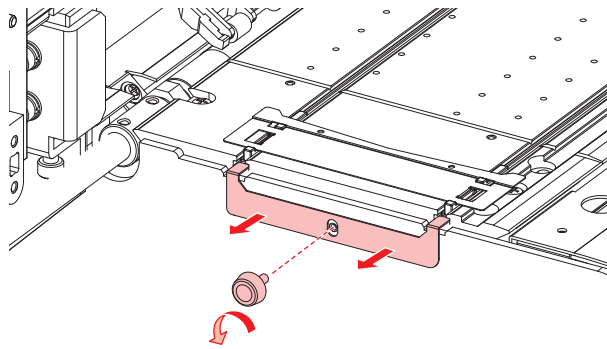

3 Remove the media holder.

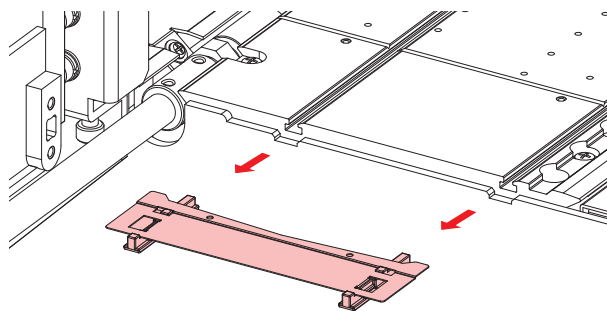

4 Remove the sliders from the media holder.

- Be careful to avoid misplacing the sliders.

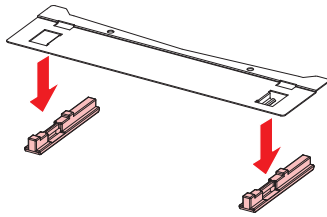

5 Mount the sliders on to the new media holder.

- Engage the holes in the sliders on to the lugs on the media holder.

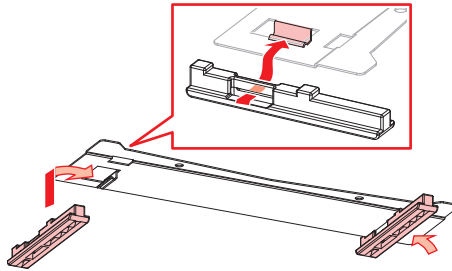

6 Mount the new media holder on to the platen.

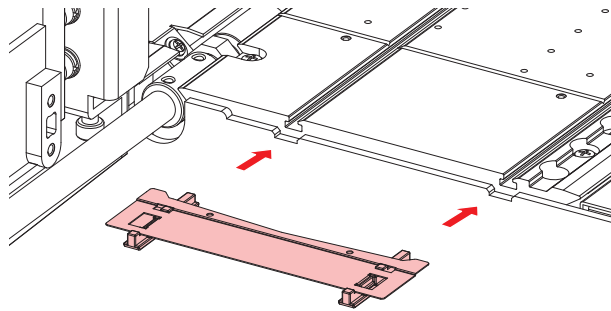

7 Secure the media holder stopper with the screw.

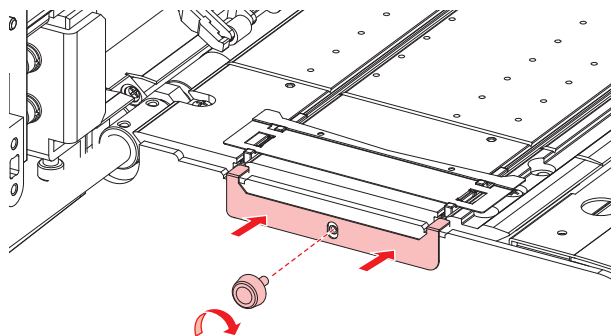

8 Close the maintenance covers.

Media Cutter Replacement

Replace cutters when blades are chipped or blunt.



- Avoid touching the cutter blade. Failure to do so may result in injury.

- 1** On the **LOCAL** mode screen, select **[MENU] > [Maintenance]**, then press the **[ENTER]** key.
 - The Maintenance menu is displayed.
- 2** Select **[Station Maint.] > [Carriage Out] > [Move To Platen Right End]**, then press the **[ENTER]** key.
 - The carriage moves over the platen.
- 3** Open the front cover.



- The carriage can be moved by hand. Move the carriage slowly to a position allowing easy access while working.

4 Replace the media cutter.

- (1) Unscrew the cutter screw.

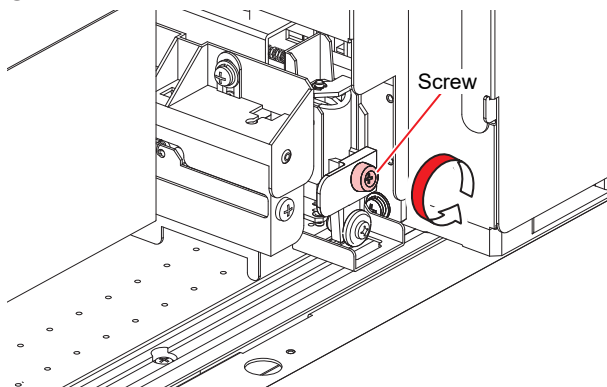

- (2) Remove the cutter.

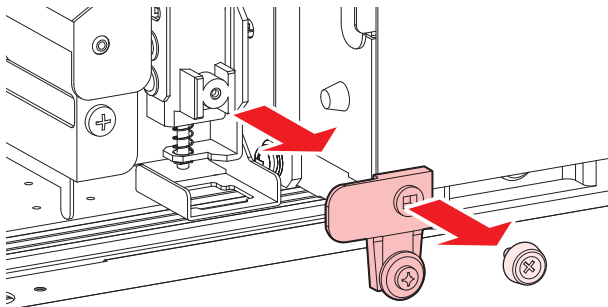

- (3) Mount a new cutter.
- (4) Tighten the screw to clamp the cutter.

5 Check the position of the media cutter.

- Lift up the media cutter by hand if it has dropped down.

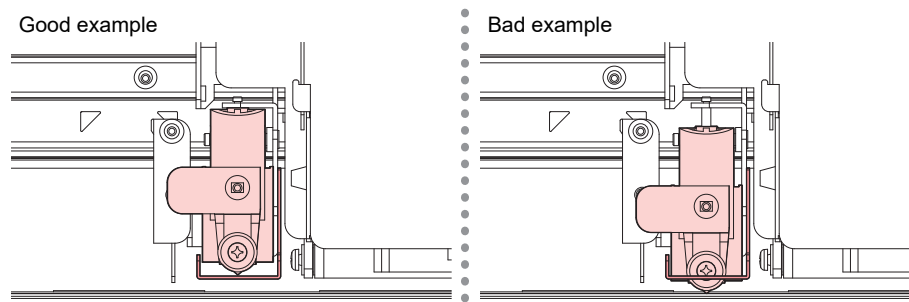

6 Once replacement is complete, close the cover, then press the [ENTER] key.

Y Cutter Replacement (XY Slitter)

JV
CJV
UCJV

- The description here applies to the JV/CJV/(UCJV)*. (* "Options"(P. 286))

Replace cutters when blades are chipped or blunt.



- Avoid touching the cutter blade. Failure to do so may result in injury.

1 Unscrew the cutter screw.

2 Remove the cutter.

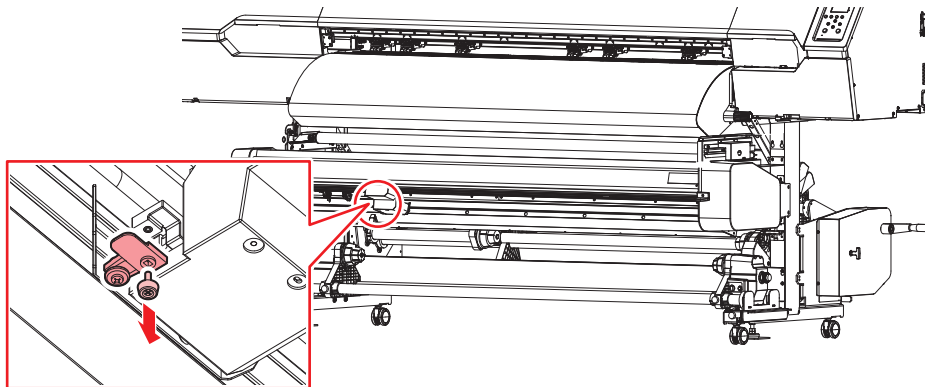

3 Insert a new cutter straight in as far as it will go.

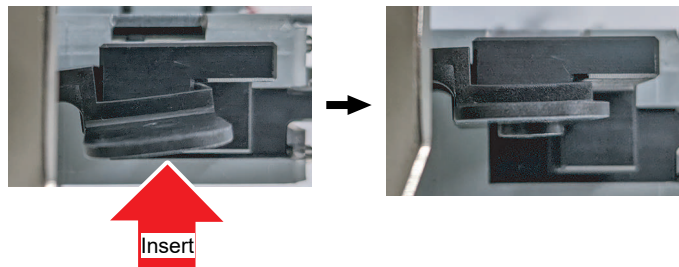

- Take care to ensure that the cutter is not inserted at an angle.

4 Tighten the screw to clamp the cutter.



- If the screw is difficult to tighten, tighten while pushing the cutter right in.

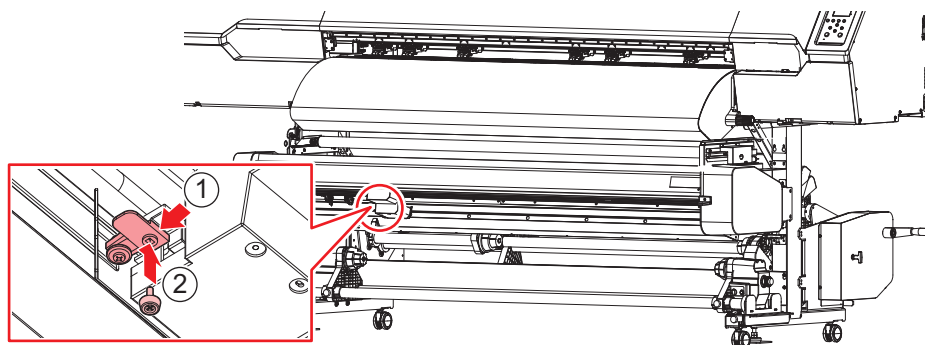

X Cutter Replacement (XY Slitter)

JV
CJV
UCJV



- The description here applies to the JV/CJV/(UCJV)*. (* "Options"(P. 286))

Replace cutters when blades are chipped or blunt.

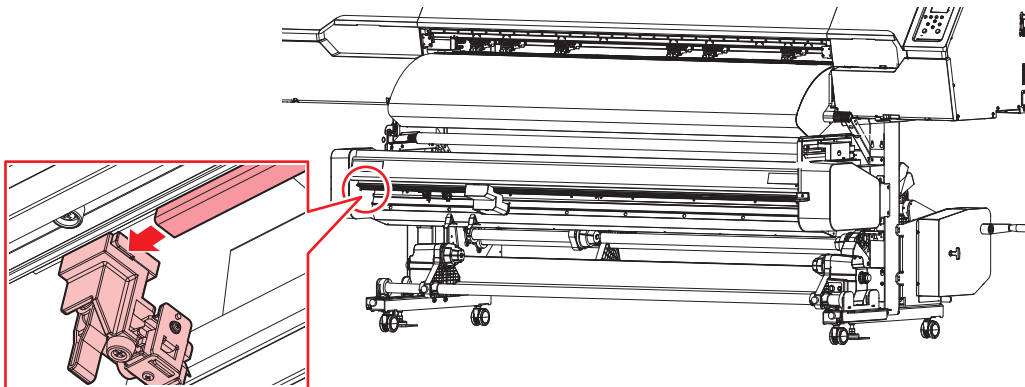

- Avoid touching the cutter blade when replacing cutters. Failure to do so may result in injury. Use radio pliers or tweezers to replace cutters.

- Slide the X cutter unit to the left-hand end to remove.



- Turn the screw and remove the cutter.

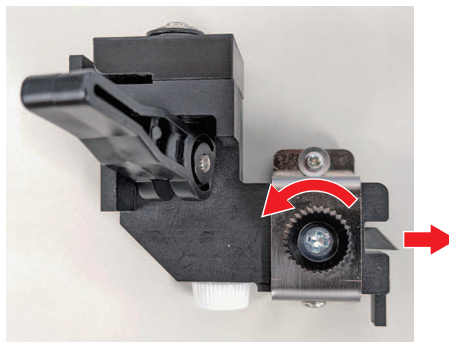

- Insert a new X cutter with the blade up until it stops.

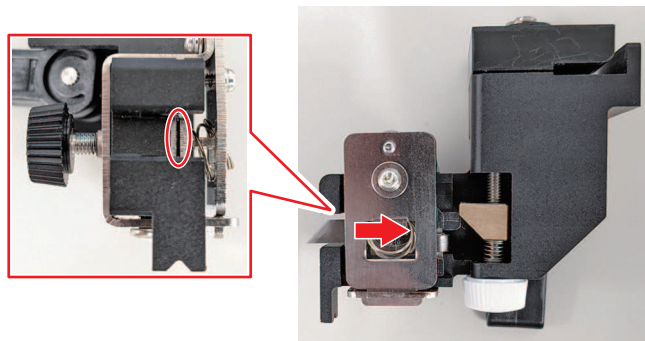

Important!

- If the blade does not stop, the blade is not positioned correctly. Reposition and insert the blade again.

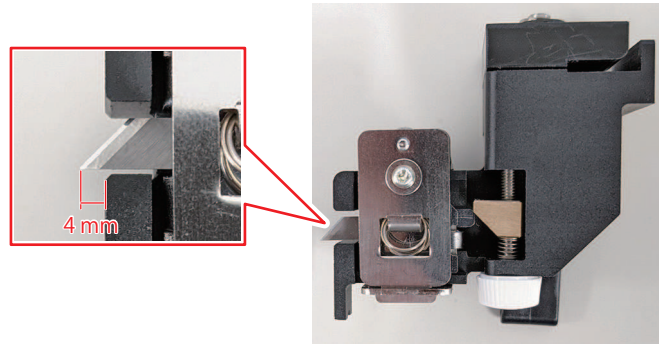
4 Check to confirm that the protrusion amount of the blade is 4 mm.

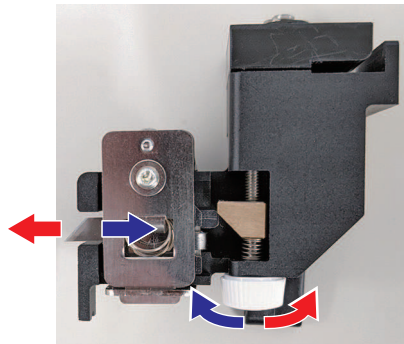

- If not, adjustment is required.
 - (1) Turn the white knob screw to adjust the protrusion of the blade.
 - Turn the screw clockwise to protrude the blade.
 - Turn the screw counterclockwise to retract the blade.



5 Tighten the screw to clamp the X cutter.

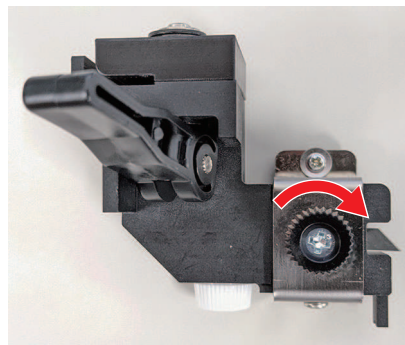

6 Insert the X cutter groove into the L-shaped slide rail.

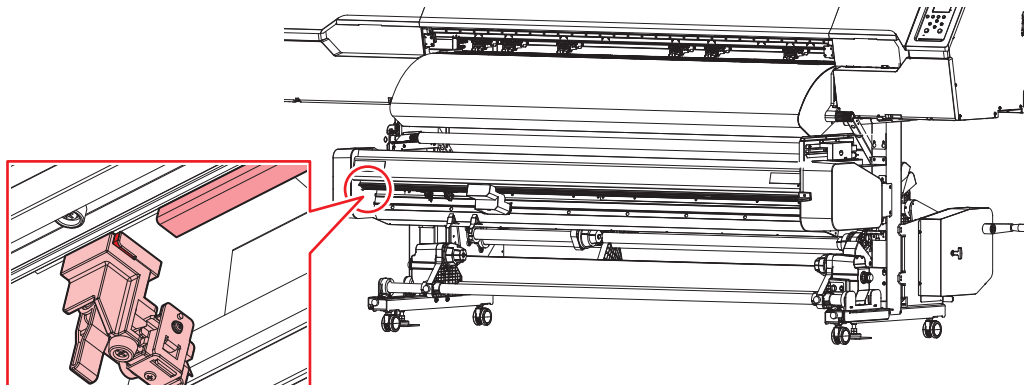

Media Edge Guide Film Replacement

JV
CJV
TS
UCJV



- The description here applies to the JV/CJV/TS/UCJV*.
- Included as standard for the TS, and optional for the JV/CJV/UCJV.

Replace the media edge guide film if it is creased or worn.

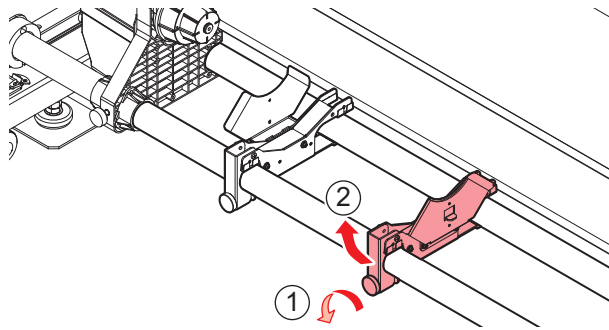
1 Turn the knob screw and open the media edge guide cover.

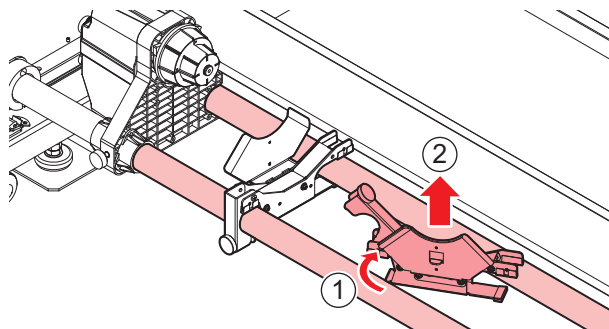

2 Rotate the media edge guides to remove them.



3 Remove the media edge guide film from the media edge guide.



- Make sure no parts of the double-sided tape remain.

4 Remove the double-sided tape on the media edge guide film and attach it to the media edge guide.

- Align and attach the film hole (x2) to the screw hole (x2) of the media edge guide.

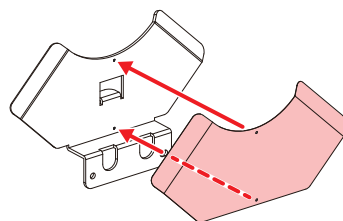

Left side

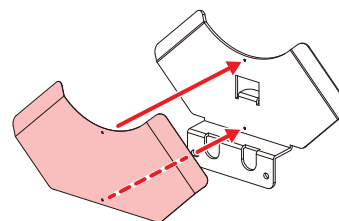

Right side

5 Position the media edge guides on the roll guides.

- (1) Insert the media edge guides between the roll guides.
- (2) Rotate the media edge guides to mount them on the roll guides.

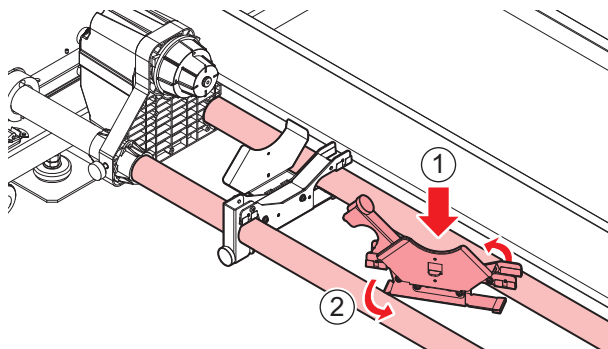

- (3) Secure the media edge guides with the knob screw.

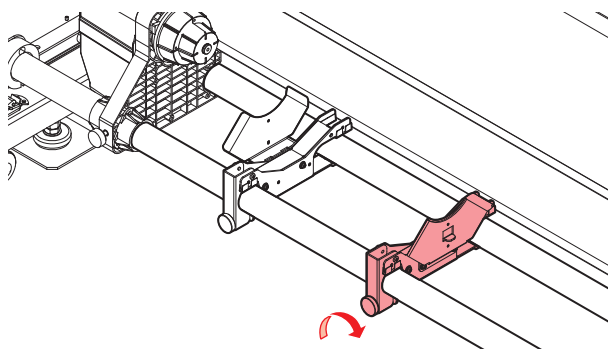

Ink Supply Unit Ink Absorber Replacement

JV
CJV
TS

- The UCJV does not include this function.

We recommend replacing the ink absorber each time you replace the ink pack, to prevent dirt building up on the pedestal of the ink supply unit.



- Pay close attention to ventilation and be sure to wear safety glasses, gloves, and a mask when handling ink, maintenance liquid, waste ink, or other solutions used with the machine. Leaking ink may adhere to the skin or get into the eyes or mouth.



- 1 Push down the lever on the pedestal, and remove the Ink eco-case.

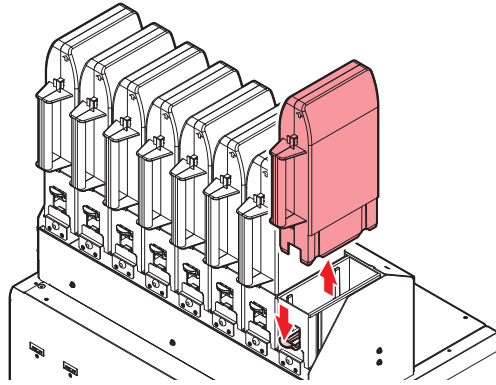

- 2 Remove the ink absorber, and replace with a new one.

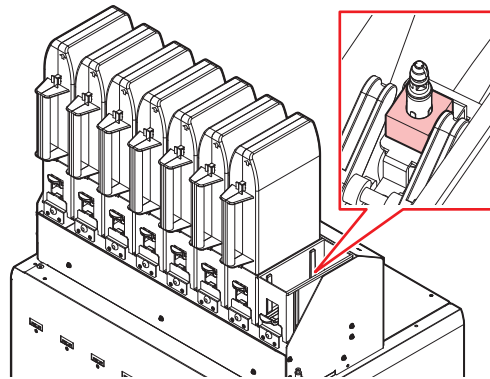

- 3 Set an eco-case on the base.

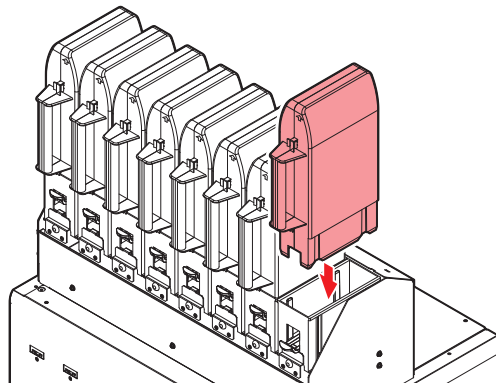

Waste Ink Tank Replacement

Ink used during head cleaning and other processes is collected in the waste ink tank at the lower right of the machine.

This product keeps track of the waste ink level. A "Check Waste Ink Tank" message appears when the preset level is reached. Use this a guide for replacing the waste ink tank.



- For a 2-liter tank, the preset level is 80 % (1.6 L).
- Continuing to use the product without disposing of the waste ink may result in waste ink overflowing from the waste ink tank. Visually check ink levels in the waste ink tank about once a week.



- Pay close attention to ventilation and be sure to wear safety glasses, gloves, and a mask when handling ink, maintenance liquid, waste ink, or other solutions used with the machine. Leaking ink may adhere to the skin or get into the eyes or mouth.



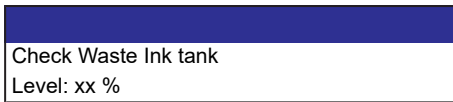

When "Check Waste Ink Tank" message appears

- 1 The "Check Waste Ink Tank" message appears on the display.



Check Waste Ink tank
Level: xx %

- 2 Check the waste ink levels in the waste ink tank.
 - If you note any discrepancies from actual levels, proceed to the next step.
 - If there is no discrepancy, replace (dispose of) the waste ink tank referring to  ["Replacing the Waste Ink Tank"\(P. 242\)](#).
- 3 On the LOCAL mode screen, select [MENU] > [Maintenance], then press the [ENTER] key.
 - The Maintenance menu is displayed.
- 4 Select [Waste Ink Tank], then press the [ENTER] key.
- 5 Select [Adjust Waste Ink Volume], then press the [ENTER] key.
- 6 Press   to adjust the level.
- 7 Press the [ENTER] key once adjustment is complete.

Replacing the Waste Ink Tank



- No tank stopper is included when the waste ink tank cover is made of plastic.

- 1 On the LOCAL mode screen, select [MENU] > [Maintenance], then press the [ENTER] key.
 - The Maintenance menu is displayed.
- 2 Select [Waste Ink Tank], then press the [ENTER] key.

- 3 Select [Reset Waste Ink Volume], then press the [ENTER] key.
- 4 Open the waste ink tank cover and unlock and pull the stopper forward.

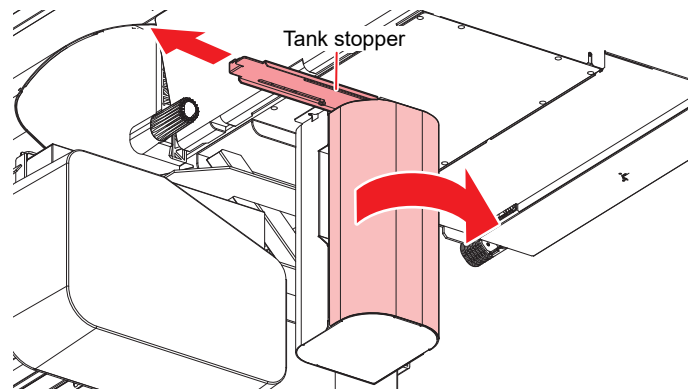

- 5 Hold the handle on the waste ink tank and slide out.

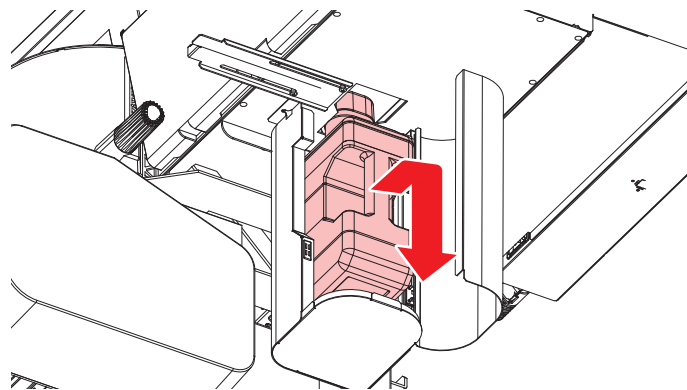

- 6 Attach the cap to the removed waste ink tank, and use tape to prevent leakage of waste ink.

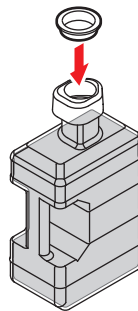

- When disposing of ink, maintenance liquid or other liquid used with the product, or containers or non-woven fabric contaminated with ink or other liquid, contact an industrial waste disposal operator or dispose of the product in accordance with the local laws and regulations.

7 Install a new waste ink tank.

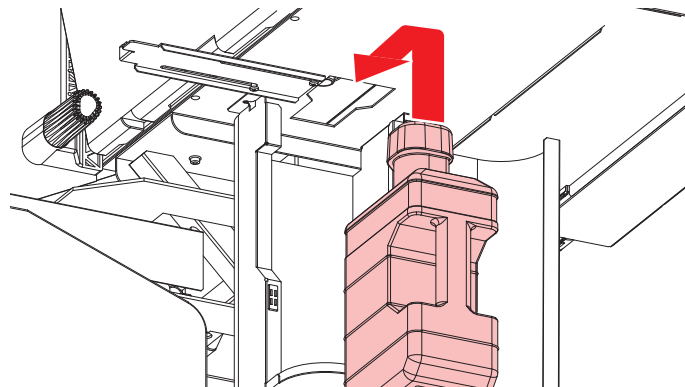

8 Return the stopper to its original position and close the waste ink tank cover.

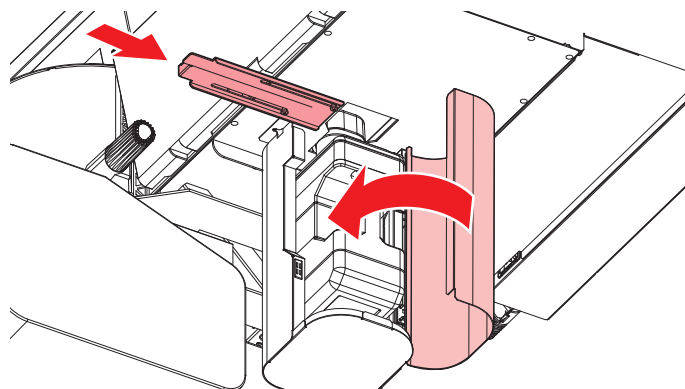

9 Press the [ENTER] key.

- The waste ink level will be reset.

Mist Filter Replacement

UCJV



- The description here applies to the UCJV.

Check the mist filter. Replace if very dirty.

- 1 On the LOCAL mode screen, select [MENU] > [Maintenance], then press the [ENTER] key.**
 - The Maintenance menu is displayed.
- 2 Select [Station Maint.] > [Carriage Out] > [Move To Maint. Space], then press the [ENTER] key.**
 - The carriage moves to the maintenance space.
- 3 Open the maintenance cover on the left side.**

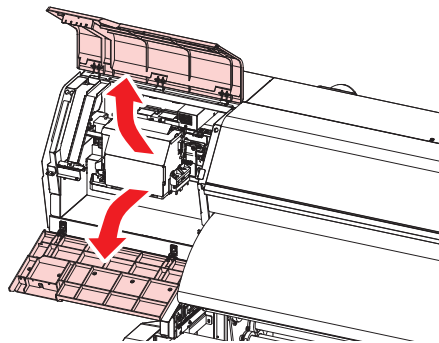

4 Remove the mist filter box.

- Push the tab in the direction indicated by the arrow and slide out in the direction of the arrow to remove.

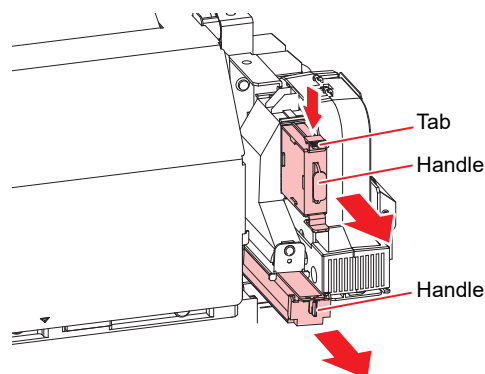

5 Replace the mist filter with a new one.

6 Install the mist filter box.

- Insert until it clicks into place. Confirm that the tab is engaged.

7 Once replacement is complete, close the cover, then press the [ENTER] key.

UV-LED Glass Replacement

UCJV



- The description here applies to the UCJV.

Replace the glass on the underside of the UV-LED unit if hardened ink is adhering to it.

- 1 On the LOCAL mode screen, select [MENU] > [Maintenance], then press the [ENTER] key.**
 - The Maintenance menu is displayed.
- 2 Select [Station Maint.] > [Carriage Out] > [Move To Platen Right End], then press the [ENTER] key.**
 - The carriage moves over the platen.
- 3 Open the front cover.**
- 4 Remove the LED glass.**
 - Push the tabs inward and slide out the glass in the direction of the arrow to remove.
 - Be careful not to apply too much force when unclipping the tabs. Disregarding this precaution may result in breakage of the tabs.

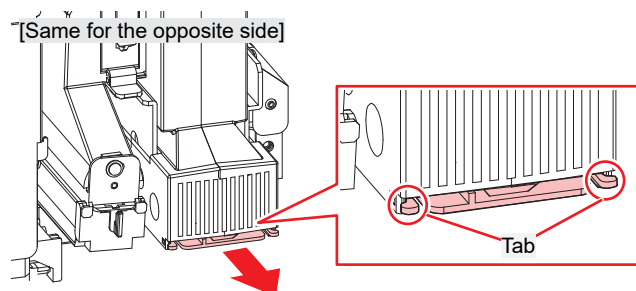

- 5 Install a new LED glass.**
 - Insert until it clicks into place. Confirm that the tabs are engaged.

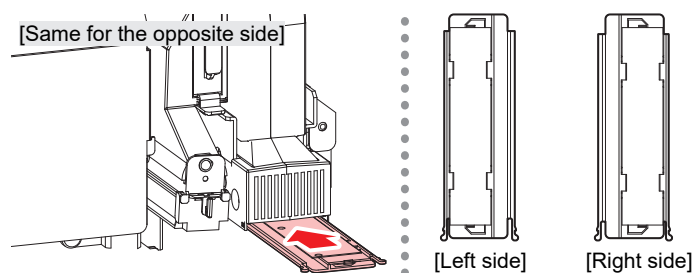

- 6 Once replacement is complete, close the cover, then press the [ENTER] key.**

Cutter for Cutting Machine

CJV

UCJV



- The description here applies to the CJV/UCJV.

Replace cutters when blades are chipped or blunt.



- Avoid touching the cutter blade. Failure to do so may result in injury.
- Do not shake or swing the cutter holder. Doing so may cause the blade to come off.

● Replacing Cutters

["Installing Cutting Tools"\(P. 108\)](#)

Pen Line Replacement

CJV

UCJV



- The description here applies to the CJV/UCJV.

This machine can be used with the following pen lines.

- Pen line rubber
Used for pen writing or cutting
- Pen line sponge
Used for half cut (cutting across a dotted line)



- Turn off the main power and unplug the power cable before replacement.

1 Open the front cover.

2 Use tweezers to peel off the end of the pen line.

- Wipe off any adhesive remaining in the platen slot with industrial alcohol.

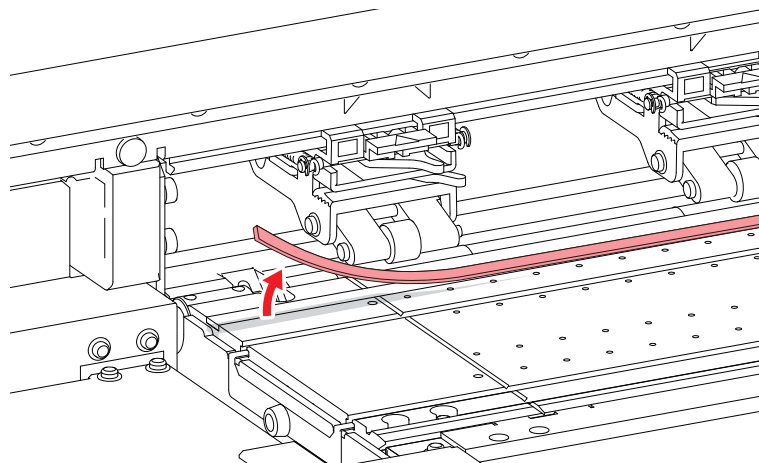

3 Attach double-sided tape in the platen slot.

- Peel off the base paper from the double-sided tape.

4 Attach the pen line on the double-sided tape.

- Make sure the pen line lies flat.

5 Close the front cover.

Bottle Cap Replacement

UCJV

Replace approximately once a year. For information on the replacement procedure, refer to  "UCJV"(P. 51).



- Pay close attention to ventilation and be sure to wear safety glasses, gloves, and a mask when handling ink, maintenance liquid, waste ink, or other solutions used with the machine. Leaking ink may adhere to the skin or get into the eyes or mouth.

Chapter 8 Troubleshooting



This chapter

This chapter describes corrective actions for troubleshooting and messages on the display.





Troubleshooting.....	250	Abnormal noise occurs during cleaning	257
The power does not turn on.	250	Cutting Related	258
Printing is not possible.	250	To Stop Circulation Operation	263
The media jams or the media is dirty.	250	Problems Causing Messages to Appear	264
Image defects occur.....	251	Warning Messages	264
The heater temperature does not rise to the specified value.	256	Ink error.....	266
The ink has leaked out.....	256	Error Message	267
The light-blocking cover comes off.....	256	SYSTEM HALT	278

8.1 Troubleshooting





For information on troubleshooting, refer to this chapter. Refer to our website (<https://mimaki.com/support/>) for frequently asked questions (FAQs) about this product and customer support videos.

If the recommended corrective action does not resolve the problem, contact your local dealer or our service office.

The power does not turn on.

Points to check	Corrective action
Is the machine connected to the power outlet by the power cable?	Connect the power plug securely to the power outlet.  "Connecting the Power Cable"(P. 37)
Are you using the power cable provided?	Use the power cable provided.
Is the main power supply turned on?	Turn on the main power supply.   "Turning On the Power"(P. 37)
Is the [END/POWER] key on the operating panel turned on?	Turn the power on.  "Turning On the Power"(P. 37)

Printing is not possible.

Points to check	Corrective action
Is a USB interface cable connected?	Connect the cable securely to the USB 2.0 port.  "Using a USB Cable"(P. 41)
Is a LAN cable connected?	Connect the cable securely to the LAN port.  "Using a LAN Cable"(P. 40)
Are you using a LAN cable approved by Mimaki?	Check the LAN cable type.  "Using a LAN Cable"(P. 40)
Is the status lamp on the operating panel illuminated or flashing red?	An error has occurred. Check the message on the display.  "Operating Panel"(P. 33)

The media jams or the media is dirty.

Points to check	Corrective action
Are you using the recommended media?	Make sure you are using the recommended media. https://mimaki.com/supply/inkjet.html
Are you using curled media?	Do not use curled media or media with folded ends.
Is the media skewed?	Use the take-up unit to adjust the media or reload the media.  "Loading the Media"(P. 66)

Points to check	Corrective action
Does the media have ripples/surface irregularities or lift up?	<p>If you are using roll media, use a smooth section of the media for initial feeding. You can also improve this problem by attaching the NITOFLO[®] tape provided on the platen.</p>  <p>Attach the tape, taking care not to block the vacuum hole.</p> <p>For more information, refer to the description on transporting media on the platen. https://mimaki.com/download/inkjet.html</p>

Image defects occur.

Symptom	Corrective action
White streaks, blurriness, and dark streaks occur. (Carriage scan direction)	<ol style="list-style-type: none"> 1. Remove any paper scraps or other debris adhering to areas over which the head passes (e.g., media holders). ☞ "Media Holder Cleaning"(P. 207) ☞ "Platen Cleaning"(P. 209) 2. Perform the procedure described in ☞ "Head Cleaning"(P. 92). 3. Perform the procedure described in ☞ "Feed Correction"(P. 93). 4. Perform the procedure described in ☞ "Cap Rubber Cleaning"(P. 198). 5. Perform the procedure described in ☞ "Carriage Underside Cleaning"(P. 198).
Text is double- or triple-printed in the media feed direction.	<ol style="list-style-type: none"> 1. Perform the procedure described in ☞ "Feed Correction"(P. 93).
Offsetting occurs during bidirectional printing.	<ol style="list-style-type: none"> 1. Perform the procedure described in ☞ "Correcting the Drop Position"(P. 95).
Ink droplets drip during printing.	<ol style="list-style-type: none"> 1. Perform the procedure described in ☞ "Cap Rubber Cleaning"(P. 198). 2. Perform the procedure described in ☞ "Carriage Underside Cleaning"(P. 198). 3. Perform the procedure described in ☞ "Head Cleaning"(P. 92). 4. Set auto maintenance. ☞ "Maintenance Menu"(P. 177)
Nozzles are clogged.	<ol style="list-style-type: none"> 1. Perform the procedure described in ☞ "Head Cleaning"(P. 92). 2. Perform the procedure described in ☞ "Print Head Nozzle Washing"(P. 253). 3. Perform the procedure described in ☞ "Registering Nozzle Recovery"(P. 179).
Are the print heads too high?	Adjust the print head height. ☞ "Adjusting Print Head Height"(P. 61) If the print heads cannot be lowered, increase the refresh level during printing (☞ P. 178) or perform regular test printing to check for nozzle clogging.
Are there any ink colors that aren't used much?	Discharge from infrequently used nozzles tends not to be consistent. Although increasing the refresh level during printing (☞ P. 178) will enable more frequent nozzle use, note that this will also increase ink consumption.

Symptom	Corrective action
Are you using media easily affected by static electricity?	Increase the refresh level during printing (☞ P. 178) or perform regular test printing to check for nozzle clogging. Otherwise, use an optional ionizer.
Is the machine installed in a location with low humidity?	Increase the humidity by installing a humidifier or similar equipment. When printing continuously, also increase the refresh level during printing (☞ P. 178) or perform regular test printing to check for nozzle clogging. Otherwise, use an optional ionizer.
Is the machine installed in a location where dust or powder is present?	Install the machine in a location free of dust or powder (office equivalent: dust level 0.15 mg/m ³).
There is considerable nozzle clogging with white ink * UCJV only	<ol style="list-style-type: none"> 1. Perform the procedure described in ☞ "Head Cleaning"(P. 92). 2. Perform the procedure described in ☞ "There is considerable nozzle clogging with white ink"(P. 254).
Uneven coloring looking like tree rings occurs. * UCJV only	<ol style="list-style-type: none"> 1. Increase the force with which the medium is held down (vacuum fan ☞ P. 176). 2. Increase the PRE (preheater) temperature. ☞ "Setting the Heater Temperature"(P. 89)

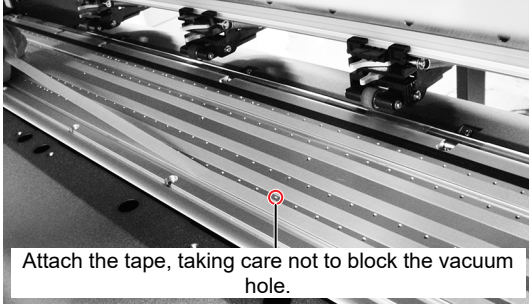
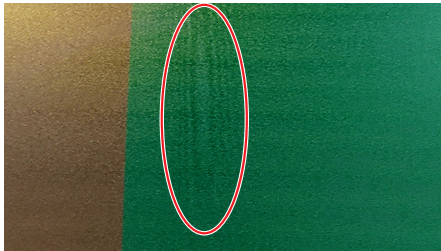

Print Head Nozzle Washing

If ejection failures (e.g., nozzle clogging or deflection) remain unresolved even after head cleaning (☞ "Head Cleaning"(P. 92)), apply nozzle wash to the print head.

JV/CJV/TS

JV
CJV
TS

- 1** On the LOCAL mode screen, select [MENU] > [Maintenance], then press the [ENTER] key.
 - The Maintenance menu is displayed.
- 2** Select [Station Maint.] > [Nozzle Wash], then press the [ENTER] key.
 - The carriage moves over the platen.
- 3** Open the maintenance cover on the right side.
- 4** Clean the cap rubber.
 - ☞ "Cap Rubber Cleaning"(P. 198)
- 5** Once cleaning is complete, close the cover, then press the [ENTER] key.
 - The cap is filled with maintenance liquid.



- Close the cover. The cap cannot be filled with maintenance liquid while the cover is open. This is also true if the maintenance liquid cartridge is empty.

- 6** Open the maintenance cover on the right side.
 - Check to confirm that the cap is filled with maintenance liquid.



- If not, use a syringe to draw up some maintenance liquid and fill until it almost overflows from the cap.

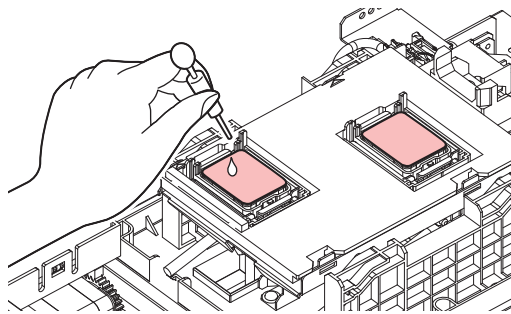

- 7** Close the maintenance covers.
- 8** Set the exposure time, then press the [ENTER] key.
 - Cleaning is performed automatically once print nozzle washing has ended.



- If ejection failures (e.g., nozzle clogging or deflection) remain unresolved even after washing the nozzles several times, contact your local dealer or our service office.

UCJV

UCJV

- 1** On the **LOCAL** mode screen, select **[MENU] > [Maintenance]**, then press the **[ENTER]** key.
 - The Maintenance menu is displayed.
- 2** Select **[Station Maint.] > [Nozzle Wash]**, then press the **[ENTER]** key.
 - The carriage moves over the platen.
- 3** Open the maintenance cover on the right side.
- 4** Clean the cap rubber.
 -  ["Cap Rubber Cleaning"\(P. 198\)](#)
- 5** Once cleaning is complete, close the cover, then press the **[ENTER]** key.
 - "Fill the Liquid. Exit Next [ENT]" appears on the display.
- 6** Fill the cap with maintenance liquid.
 - Use a syringe to draw up some maintenance liquid and fill until it almost overflows from the cap.

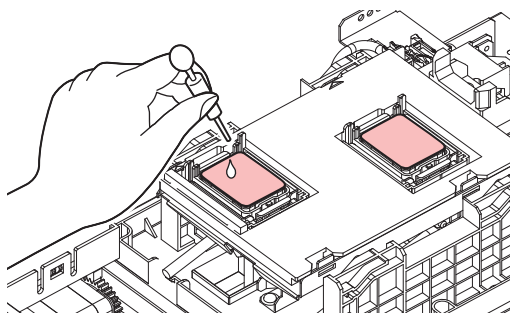

- 7** Close the maintenance cover, then press the **[ENTER]** key.
- 8** Set the exposure time, then press the **[ENTER]** key.
 - Cleaning is performed automatically once print nozzle washing has ended.



- If ejection failures (e.g., nozzle clogging or deflection) remain unresolved even after washing the nozzles several times, contact your local dealer or our service office.

There is considerable nozzle clogging with white ink

If there is considerable nozzle clogging with white ink (dropouts), perform Air PG. Note that this consumes a large amount of ink.

- 1** On the **LOCAL** mode screen, select **[MENU] > [Maintenance]**, then press the **[ENTER]** key.
 - The Maintenance menu is displayed.
- 2** Select **[Air PG]**, then press the **[ENTER]** key.

3 Press , then select [YES].

Air PG	
A large amount of ink will be consumed. Continue?	
NO <	> YES



4 Press , then select [YES].

Air PG	
Do ejection failures involving large amounts of waste?	
NO <	> YES

5 The "Check Waste Ink Tank" message appears on the display.

Check Waste Ink tank	
Level: xx %	

6 Check the waste ink levels in the waste ink tank.

- If there are discrepancies from actual levels, correct the waste ink amount.  ["When "Check Waste Ink Tank" message appears"\(P. 242\)](#)
- If there is no discrepancy, replace (dispose of) the waste ink tank referring to  ["Replacing the Waste Ink Tank"\(P. 242\)](#).

7 Press the [ENTER] key to start air purging.



Air PG	
Air PG	
Start	[ENT]

8 Perform a test print and check the print results.

-  ["Test Printing"\(P. 90\)](#)

The heater temperature does not rise to the specified value.

This may indicate a problem with the setting.

Points to check	Corrective action
Is the 100V/200V selector switch set correctly?	Set the selector switch according to the power supply voltage.
Is the heater temperature set?	Set the heater temperature.  "Setting the Heater Temperature"(P. 89)  "Media Setting Menu"(P. 174)

The ink has leaked out



- If an ink leak occurs, turn off the main power immediately and unplug the power cable. Then, contact your local dealer or our service office.

The light-blocking cover comes off.

UCJV

If the light-blocking cover is left off, the ink inside the ink supply unit may be exposed to light and begin to harden.

If the light-blocking cover comes loose, reattach as follows:

- 1 Insert the lug on one side of the light-blocking cover into the corresponding hole in the tank.

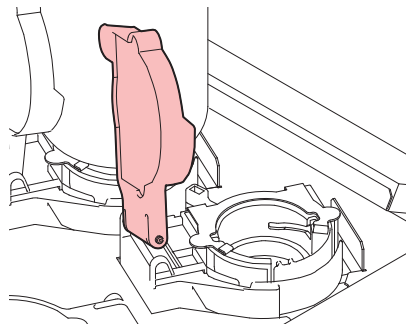

- 2 Insert the lug on the other side while pushing in toward the first hole in Step 1.

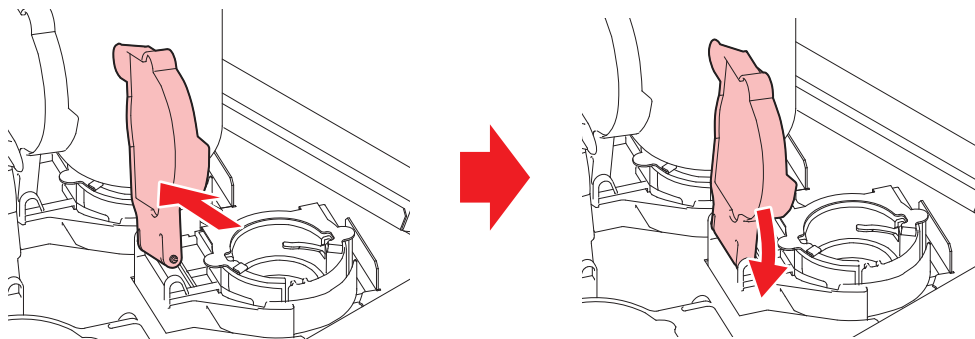

Abnormal noise occurs during cleaning

Cloth wiper may be entangled in the cloth wiper gear. Remove the cloth wiper and replace it.

Important!

- Perform the following procedure: Use the [Replace Wiper] menu to reset the wiper remaining amount.



- When handling **SPC-0919 or SPC-0932 cloth wipers**, be sure to wear safety glasses, gloves, and a mask. There is a risk of the liquid (solvent) contained in cloth wipers splashing and contacting your skin, eyes, or mouth.



- 1 On the LOCAL mode screen, select [MENU] > [Maintenance], then press the [ENTER] key.
 - The Maintenance menu is displayed.
- 2 Select [Station Maint.] > [Carriage Out] > [Move To Platen Right End], then press the [ENTER] key.
 - The carriage moves over the platen.
- 3 Open the maintenance cover on the right side.
- 4 Open the cloth wiper cover.
 - Push the two tabs at the front up to open.

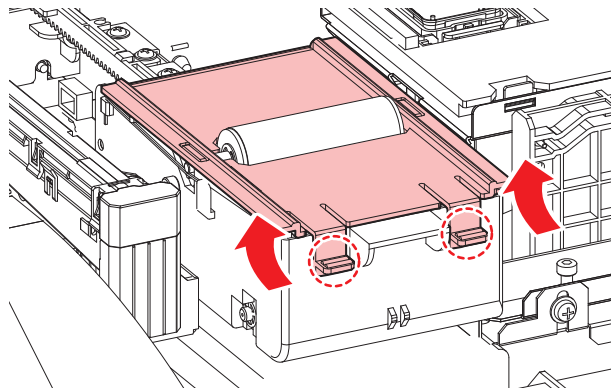

- 5 Remove the cloth wiper together with the spindle, then replace it.

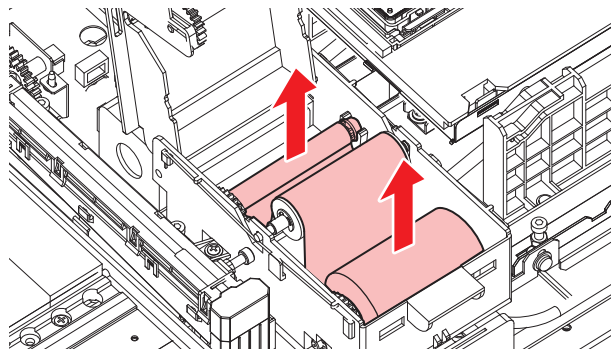

Cutting Related

CJV

UCJV

Symptom	Corrective action
The cut position shifts.	This may indicate a problem with the register mark sensor. Perform the operation used to check the responsiveness of the register mark sensor. You cannot check the responsiveness of the register mark sensor manually. "Adjusting the Position of the Register Mark Sensor"(P. 258)
Cutting is not possible.	Cut a sample stored in the machine to identify the cause. Executing a sample cut will clear any data saved in the receive buffer. "Investigating the Cause of Cutting Failures"(P. 260)
The print and cut positions are misaligned.	Use the MIMAKI RIP software (RasterLink) to print a correction pattern. Check the correction pattern and input correction values manually. "Adjusting to Correct Misalignment Between Printing and Cutting"(P. 260)
The print and cut positions are misaligned in the scan direction.	Print the correction pattern to perform automatic correction. <ol style="list-style-type: none"> Position the media. <ul style="list-style-type: none"> Prepare white media used to print a correction pattern. On the LOCAL mode screen, select [MENU] > [Cutting], then press the [ENTER] key. <ul style="list-style-type: none"> The Cutting menu is displayed. Select [Maintenance] > [Scale Adjust], then press the [ENTER] key. When the confirmation screen is displayed, press the [ENTER] key. <ul style="list-style-type: none"> Print the correction pattern to perform automatic correction.

Adjusting the Position of the Register Mark Sensor

- 1 Prepare the media on which register marks are printed.**
 - ["Creating Register Marks"\(P. 124\)](#)
- 2 On the LOCAL mode screen, select [MENU] > [Cutting], then press the [ENTER] key.**
 - The Cutting menu is displayed.
- 3 Select [Maintenance] > [Marks Sensor] > [Sensor Check], then press the [ENTER] key.**
 - The cutting unit moves over the platen.
- 4 Press to move the LED pointer.**

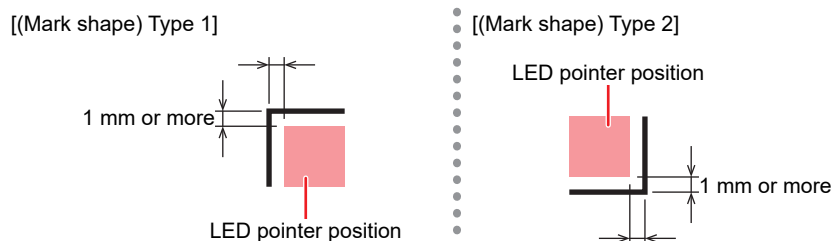

- 5 Register the information corresponding to the printed register mark conditions.**
 - ["Setting Mark Detection Conditions"\(P. 130\)](#)
 - The set register mark conditions are also stored in [Cutting] > [Mark Detect]. The settings are retained even when the power is turned off.

6 Press [ENTER] to start the detection operation.

- The machine automatically detects the lines in the X and Y directions (automatic detection operation: plus X direction > minus X direction > plus Y direction > minus Y direction).

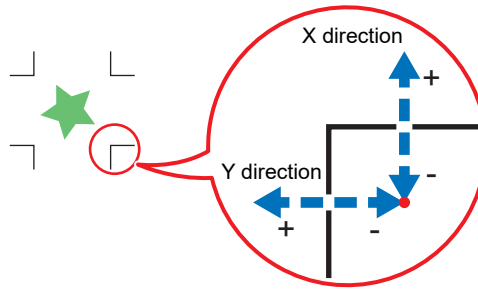

- A buzzer sounds each time a line is detected (four buzzers in all). If any of the buzzers fails to sound, refer to the following:

["Correcting the LED Pointer Position"\(P. 259\)](#)

Correcting the LED Pointer Position

If the register marks cannot be read properly, the register mark sensor may be misaligned. Refer to the following to correct the position of the register mark sensor:

- 1 Attach a pen to the tool holder.**
 - ["Using a Pen"\(P. 112\)](#)
- 2 Load copy paper.**
- 3 On the LOCAL mode screen, select [MENU] > [Cutting], then press the [ENTER] key.**
 - The Cutting menu is displayed.
- 4 Select [Maintenance] > [Marks Sensor] > [Pointer Offset], then press the [ENTER] key.**
 - A 10 mm cross pattern is drawn.
 - The LED pointer turns on and moves to the center of the cross pattern.
- 5 Press to move the LED pointer to the center of the cross pattern.**

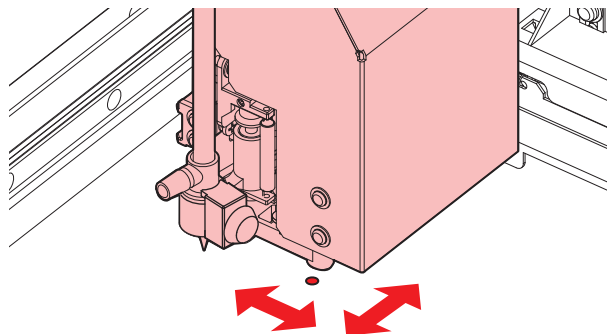

6 Press the [ENTER] key to complete the settings.

- The settings are retained even if [Setup Reset] is selected.

7 Check the following again.

- ["Adjusting the Position of the Register Mark Sensor"\(P. 258\)](#)
- If the buzzer does not sound four times, check the printed register mark conditions and contact your local distributor, our sales office, or service center.

Investigating the Cause of Cutting Failures

- 1 On the LOCAL mode screen, select [MENU] > [Cutting], then press the [ENTER] key.
 - The Cutting menu is displayed.

- 2 Select [Maintenance] > [Sample Cut], then press the [ENTER] key.

- 3 Select the sample data, then press the [ENTER] key.

- There are two sample types: "Cut" and "Logo".



- If you select "Cut", press the [ENTER] key to start cutting.
- If you select "Logo", refer to the following:
 - (1) Press ▲ ▼ to specify the scaling factor (1 to 999 %).
 - (2) Press the [ENTER] key to start cutting
 - The settings are retained even if [Setup Reset] is selected.

● Sample Cut Results

- Sample data can be cut properly, but not other data.
 - There is a problem with the host PC.
- Sample data as well as other data cannot be cut properly.
 - There is a problem with the printer. Increase the pressure in the Adj-prs Offset menu. 🗨️ "Cutting Menu"(P. 188)

Adjusting to Correct Misalignment Between Printing and Cutting

In the procedure described below, MIMAKI RIP software (RasterLink) is used to print a correction pattern. When printing and cutting, correction is required for each resolution in the scan (Y) direction. (The corrected value is saved for each resolution.) Print a pattern for each resolution, then input the correction value.

- 1 Switch the machine to REMOTE mode.

- 2 Set the print conditions (profile/cut conditions) for the job you want to print in RasterLink.

- Specify the following settings by clicking the function icons shown on the right-hand side of the screen:

 (General Print): Specifies settings like enlargement/reduction and rotation.

 (Quality): Selects a color profile for the media and ink set loaded in this machine.



- For more information, refer to the RasterLink reference guide. <https://mimaki.com/download/software.html>

- 3 Click  (General Print) and click on [Print & Cut origin adjust] on the [Cut Edit] tab.

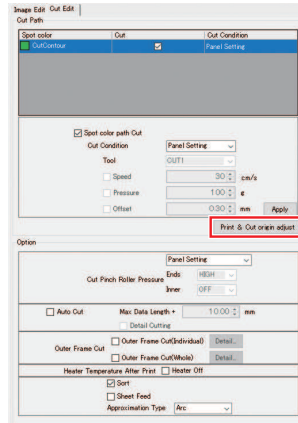

Important! • Note that the input units vary depending on whether or not register marks are used.

Without register marks

- 1 Click [OK] to print a correction pattern.

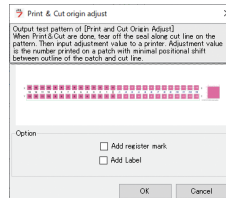

- 2 On the REMOTE mode screen, select [Adjust].

- 3 Select [PC Origin Offset], then press the [ENTER] key.

- A correction pattern is cut. Detach the cut part of the pattern and check the adjustment values.

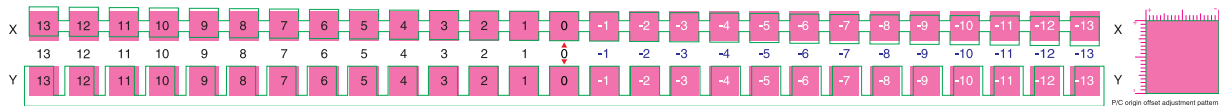

- 4 Input the numerical value of the position with the lowest vertical misalignment.

- In the illustration below, enter "-4".



- 5 Input the numerical value of the position with the lowest horizontal misalignment.

- In the illustration below, enter "2".



With register marks

1 Select [Add register mark].

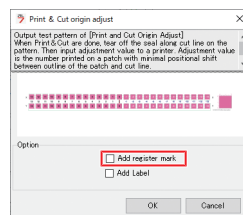

2 Click [OK] to print a correction pattern.

3 On the REMOTE mode screen, select [Adjust].

4 Select [TP Offset], then press the [ENTER] key.

- The register marks are detected, and a correction pattern is cut. Detach the cut part of the pattern and check the adjustment values.

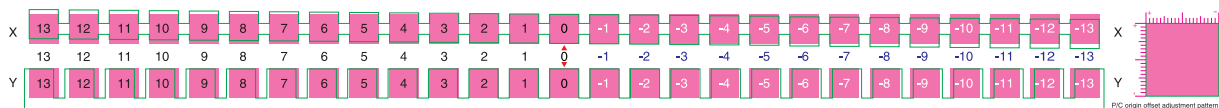

5 Input the numerical value of the position with the lowest vertical misalignment.

- In the illustration below, the value is "-4", so enter "-0.4 mm".

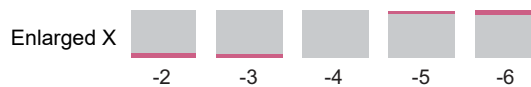

6 Input the numerical value of the position with the lowest horizontal misalignment.

- In the illustration below, the value is "2", so enter "0.2 mm".

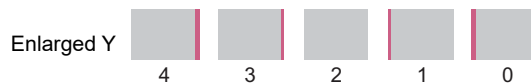

8.2 To Stop Circulation Operation

JV
CJV
UCJV



- The description here applies to the JV/CJV/UCJV.

When white or orange ink is installed, the ink is circulated periodically to prevent it from sedimenting. The procedure to stop circulation while the power is turned on is as follows:

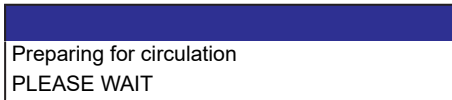
- 1 Press the [END] key when [Preparing for circulation] or [Circulation] is displayed on the screen.

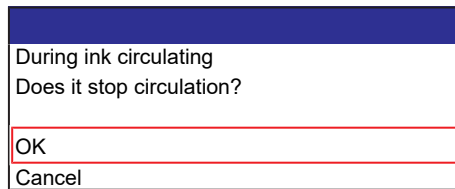

- 2 Use the ▲▼ keys to select [OK], then press the [ENTER] key.



- The ink is automatically supplied and circulation stops.



- When circulation has been stopped, it will restart after a preset period of time has elapsed.



- With the UCJV, circulation takes approximately 20 minutes.









8.3 Problems Causing Messages to Appear

If a problem arises, the buzzer sounds and a message appears on the display.

You can also check the local guidance.  ["Displaying Machine Information \(Local Guidance\)"\(P. 36\)](#)

Take the appropriate action in accordance with the content of the message. If a message reappears even after taking the prescribed action, contact your local dealer or our service office.

Warning Messages

Message	Cause	Corrective action
Replace NCU Ink Pad	<ul style="list-style-type: none"> The ink absorber needs to be replaced. 	<ul style="list-style-type: none"> The NCU ink absorber must be replaced. Contact your local distributor, our sales office, or service center.
Replace NCU	<ul style="list-style-type: none"> A problem was detected with the nozzle clogging assessment. 	<ul style="list-style-type: none"> Clean the NCU.  "NCU Cleaning"(P. 200) Replace the NCU if the error does not clear. Contact your local distributor, our sales office, or service center.
NCU Sensor Lv Low	<ul style="list-style-type: none"> The sensor's sensitivity is impaired. 	<ul style="list-style-type: none"> Clean the NCU.  "NCU Cleaning"(P. 200) Replace the NCU if the error does not clear. Contact your local distributor, our sales office, or service center.
NCU Sens Adj Err H	<ul style="list-style-type: none"> Sensor sensitivity adjustment failed. 	
NCU Sens Adj Err L		
NCU Connect	<ul style="list-style-type: none"> A problem was detected with the NCU connection. 	<ul style="list-style-type: none"> Turn off the power on the machine and turn it on after a while.
Ink Error	<ul style="list-style-type: none"> An ink error occurred. 	<ul style="list-style-type: none"> Check the ink error details.  "Ink error"(P. 266)
COVER OPEN	<ul style="list-style-type: none"> The cover is open. 	<ul style="list-style-type: none"> Close the cover.
Lower the clamp lever	<ul style="list-style-type: none"> The clamp lever is raised. 	<ul style="list-style-type: none"> Lower the clamp lever.  "Front"(P. 26)
Data Remain	<ul style="list-style-type: none"> Print (RIP) data was received. 	<ul style="list-style-type: none"> Switch to REMOTE mode and start printing or clear the data and abort printing.
Temporary Suspension	<ul style="list-style-type: none"> Printing has been paused. 	<ul style="list-style-type: none"> Switch to REMOTE mode and resume printing or clear the data and abort printing.
Printing not possible/ink IC	<ul style="list-style-type: none"> An unusable ink IC chip is used. 	<ul style="list-style-type: none"> Replace with new ink and a new ink IC chip.  "Replacing Ink"(P. 46)
No Media	<ul style="list-style-type: none"> No media is loaded, or the sensors are faulty. 	<ul style="list-style-type: none"> Load the media.  "Loading the Media"(P. 66) Clean the media sensor.  "Media Sensor Cleaning"(P. 205)
Please load media	<ul style="list-style-type: none"> No media is loaded, or the sensors are faulty. 	<ul style="list-style-type: none"> Load the media.  "Loading the Media"(P. 66)
Media Undetected	<ul style="list-style-type: none"> The media width has not been detected. 	<ul style="list-style-type: none"> Detect the media width.  "Loading the Media"(P. 66)

Message	Cause	Corrective action
Wiper Move Failure	<ul style="list-style-type: none"> The wiper is not operating correctly. 	<ul style="list-style-type: none"> Turn off the power on the machine and turn it on after a while.
Replace Wasteinktank	<ul style="list-style-type: none"> The waste ink tank count exceeded the preset value (90%). 	<p>Automatic maintenance is not possible while the covers are open. Perform the following steps:</p> <ol style="list-style-type: none"> Check the waste ink levels in the waste ink tank. "When "Check Waste Ink Tank" message appears"(P. 242) Replace the waste ink tank, then reset the waste ink level. "Replacing the Waste Ink Tank"(P. 242)
Check Waste Ink tank	<ul style="list-style-type: none"> The waste ink tank count exceeded the preset value (80%). 	<ol style="list-style-type: none"> Check the waste ink levels in the waste ink tank. "When "Check Waste Ink Tank" message appears"(P. 242) Replace the waste ink tank, then reset the waste ink level. "Replacing the Waste Ink Tank"(P. 242)
WashLiquidCart.None	<ul style="list-style-type: none"> No maintenance liquid cartridge is loaded. 	<ul style="list-style-type: none"> Load the maintenance liquid cartridge.
Please replace wash liquid cartridge	<ul style="list-style-type: none"> The maintenance liquid has run out. 	<ul style="list-style-type: none"> Replace with a new maintenance liquid cartridge.
Washing liquid end	<ul style="list-style-type: none"> The maintenance liquid has run out. 	<ul style="list-style-type: none"> Replace with a new maintenance liquid cartridge.
High ambient temp ** ° C	<ul style="list-style-type: none"> Ambient temperatures are too high. 	<ul style="list-style-type: none"> Adjust ambient temperatures to temperatures within the specified range. Optimum print quality may not be possible unless ambient conditions are within the specified range. "Installation Precautions"(P. 18)
Low ambient temp ** ° C	<ul style="list-style-type: none"> Ambient temperatures are too low. 	
Perform an air purge.	<ul style="list-style-type: none"> The message is displayed every month to keep ink inside the ink routes from hardening. 	<ul style="list-style-type: none"> Perform an air purge. "There is considerable nozzle clogging with white ink"(P. 254)
Auto-correction failed	<ul style="list-style-type: none"> White media is not used. The media is dirty. The media lifts up. There is dirt around the sensor. 	<ul style="list-style-type: none"> Load white and clean media. Load media so it does not lift up. Clean the area around the sensor. "DAS (Automatic Correction Function) Sensor Cleaning"(P. 202) If automatic correction fails repeatedly, correct the position manually. "Feed Correction"(P. 93) "Correcting the Drop Position"(P. 95)
Wiper End	<ul style="list-style-type: none"> The cloth wiper has run out. 	<ul style="list-style-type: none"> Replace with a new cloth wiper. "Cloth Wiper Replacement"(P. 219)
Wiper Near End	<ul style="list-style-type: none"> The remaining amount of cloth wiper is low. 	<ul style="list-style-type: none"> The ink will run out soon. Have a new cloth wiper ready. "Cloth Wiper Replacement"(P. 219)
Cleaning was executed because a large ambient temp. change was detected. Check the nozzle condition.	<ul style="list-style-type: none"> A large temperature change than expected ^{*1} was detected. (*1: 330 	<ul style="list-style-type: none"> Perform a test print to check the nozzle state. "Test Printing"(P. 90)



Message	Cause	Corrective action
	<p>Series: 10 °C or more/ UCJV Series: 8 °C or more)</p> <ul style="list-style-type: none"> • Cleaning was performed automatically when the power was turned on to protect the nozzle condition if a temperature changed after the power was turned off. 	

Ink error







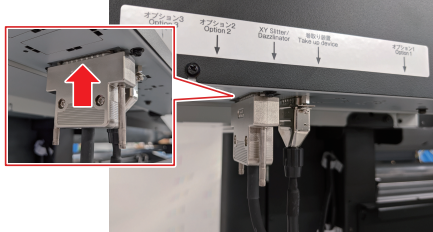

Message	Cause	Corrective action
Ink End	<ul style="list-style-type: none"> • The ink has run out. 	<ul style="list-style-type: none"> • Replace with new ink. "When Ink End is Displayed"(P. 45) • If you use UISS, you may perform cleaning.
Ink Near End	<ul style="list-style-type: none"> • Ink levels are low. 	<ul style="list-style-type: none"> • The ink will run out soon. Have new ink ready. "When Ink Near End is Displayed"(P. 45)
Non Ink IC	<ul style="list-style-type: none"> • No ink IC chip was detected. 	<ol style="list-style-type: none"> 1. Insert the ink IC chip. "Replacing Ink"(P. 46) 2. Check to confirm the ink IC chip was inserted correctly. "Mounting the ink"(P. 49) 3. Turn off the power on the machine and turn it on after a while.
Wrong Ink IC	<ul style="list-style-type: none"> • An error occurred with the information on the ink IC chip. 	<ol style="list-style-type: none"> 1. Check to confirm the ink IC chip was inserted correctly. "Mounting the ink"(P. 49) 2. Turn off the power on the machine and turn it on after a while. 3. Replace with new ink. "Replacing Ink"(P. 46)
Ink Color	<ul style="list-style-type: none"> • The ink color registered on the IC chip is different from the ink color filled. 	<ul style="list-style-type: none"> • Insert an ink IC chip for the correct ink color. "Mounting the ink"(P. 49)
Ink Type	<ul style="list-style-type: none"> • The ink type registered on the IC chip is different from the ink type filled. 	<ul style="list-style-type: none"> • Insert an ink IC chip for the correct ink type. "Mounting the ink"(P. 49)
Expiration Near	<ul style="list-style-type: none"> • The ink has expired. 	<ul style="list-style-type: none"> • Replace with new ink or use up as quickly as possible. Printing is possible. "When Ink End is Displayed"(P. 45)
Expiration Over	<ul style="list-style-type: none"> • The ink is two months past its expiration date and cannot be used. 	<ul style="list-style-type: none"> • Replace with new ink. Printing is not possible. "When Ink End is Displayed"(P. 45)







Error Message

Error number	Message	Cause	Corrective action
04	PARAM ROM	<ul style="list-style-type: none"> A problem was detected with the main PCB. 	<ul style="list-style-type: none"> Turn off the power on the machine and turn it on after a while.
108	HD THERMIS[12]	<ul style="list-style-type: none"> A problem was detected with print head temperature control. 	
108	HD CONNECT[12]	<ul style="list-style-type: none"> A problem was detected with the print head connection. 	
108	HD MEM EMP[12]	<ul style="list-style-type: none"> A problem was detected with the print head. 	
10e	FROM CLEAR	<ul style="list-style-type: none"> A problem was detected with the main PCB. 	
10f	FROM WRITE		
115	PCB MAIN-F1		
122	CHECK:SDRAM	<ul style="list-style-type: none"> A problem was detected with the SDRAM. 	
122	PRAM NONE		
123	PRAM DATA	<ul style="list-style-type: none"> A problem was detected with the main PCB. 	
124	PRAM ADDR		
127	POWER OFF		
128	HDC FIFO OVER		
128	HDC FIFO UNDER	<ul style="list-style-type: none"> A problem was detected with the print head control PCB. 	
129	Battery Exchange	<ul style="list-style-type: none"> The internal clock battery is spent and must be replaced. 	<ul style="list-style-type: none"> Contact your local distributor, our sales office, or service center.
12a	HDC SPEED	<ul style="list-style-type: none"> A problem was detected with the print head control. 	<ul style="list-style-type: none"> Turn off the power on the machine and turn it on after a while.
12d	PCB MAIN-F4	<ul style="list-style-type: none"> A problem was detected with the main PCB. 	
130	HD DATA SEQ	<ul style="list-style-type: none"> A problem was detected with the print head control. 	
147	DS-IC BUSY	<ul style="list-style-type: none"> Ink IC control abnormality detected. 	
148	E-LOG SEQ	<ul style="list-style-type: none"> A log control abnormality was detected. 	
151	Main PCB V1R2	<ul style="list-style-type: none"> A problem was detected with the main PCB power supply circuit. 	
152	Main PCB V2R5		
153	Main PCB V3R3		
154	Main PCB V05		
155	Main PCB V42-1		
15f	HEAD DRIVE HOT	<ul style="list-style-type: none"> The HDCE PCB COM driver is hot. 	



Error number	Message	Cause	Corrective action
171	NEW HEAD CONNECT	<ul style="list-style-type: none"> A new print head connection was detected. 	
17e	PCB INKCTR	<ul style="list-style-type: none"> A communication error was detected between the boards. 	
186	HDC OVERFLOW/HDC UNDERFLOW	<ul style="list-style-type: none"> A problem was detected with the print head control. 	
187	HDC SLEW RATE		
188	HDC MEMORY		
18c	Main PCB V12	<ul style="list-style-type: none"> A problem was detected with the main PCB power supply. 	
18e	FLS NOT COMP	<ul style="list-style-type: none"> A problem was detected with the print head control. 	
18f	OFFSET START [12]		
18f	OFFSET END [12]		
19f	LED CONNECT	<ul style="list-style-type: none"> The UV- LED PCB could not be detected. 	
1b5	SLIDER CONNECT	<ul style="list-style-type: none"> Unable to detect the HDCE PCB. 	<ul style="list-style-type: none"> Turn off the power on the machine and turn it on after a while.
1bf	PCB MAIN-F2	<ul style="list-style-type: none"> A problem was detected with the main PCB. 	
1d8	HEAD XHOT[12]	<ul style="list-style-type: none"> A problem was detected with the print head. 	
1e6	PRAM Size Shortage	<ul style="list-style-type: none"> Insufficient memory 	
1e9	PCB INKCTR-F*	<ul style="list-style-type: none"> A blown fuse on the ink supply 2LC PCB was detected. 	
201	Command Error	<ul style="list-style-type: none"> Data other than print (RIP) data was received, or a problem was detected with the print (RIP) data received. 	<ol style="list-style-type: none"> Clear the data and resend. Check the USB/Ether cable connection.  "Connecting a PC to the Product"(P. 40) Use a compatible cable.  "Connecting a PC to the Product"(P. 40) Turn off the power on the machine and turn it on after a while.
202	Parameter Error	<ul style="list-style-type: none"> A problem was detected with the print (RIP) data received. 	
206	Print Mode Error	<ul style="list-style-type: none"> Print (RIP) data was received with print parameters that do not allow printing. 	<ul style="list-style-type: none"> Change the output parameters and profile using RIP software.
20A	Driver Version	<ul style="list-style-type: none"> Printing is not possible because the Mimaki driver version is old. 	<ul style="list-style-type: none"> Install the latest Mimaki driver available from: https://mimaki.com/download/inkjet.html
303	PCB MAIN ET	<ul style="list-style-type: none"> A problem was detected with the main PCB. 	<ol style="list-style-type: none"> Turn off the power on the machine and turn it on after a while.

Error number	Message	Cause	Corrective action
304	USB INIT ERR	<ul style="list-style-type: none"> A problem was detected with the USB cable connection. 	<ol style="list-style-type: none"> Check the USB cable connection. "Using a USB Cable"(P. 41) Use a compatible cable. "Using a USB Cable"(P. 41) Turn off the power on the machine and turn it on after a while.
305	USB TIME OUT		
315	No resp from XY Slitter	<ul style="list-style-type: none"> Unable to detect a response from the XY slitter. The XY clamp lever was operated (raised or lowered) when one of the following errors had occurred: <ul style="list-style-type: none"> Error 48f: XY Slitter Motor X Error 490: XY Slitter Motor Y Error 491: XY Slitter X Current Error 492: XY Slitter Y Current Error 55a: XY Slitter Y Origin 	<ol style="list-style-type: none"> Check to confirm that the XY slitter cable is connected to the machine.  Check to confirm that the XY carriage is stopped. Select [MENU] > [Function Setting] > [Finisher] > [None]. Select [MENU] > [Function Setting] > [Finisher] > [XY Slitter].
316	XYSlitter transmit error	<ul style="list-style-type: none"> A problem was detected with the transmission data sent to the XY slitter. 	<ul style="list-style-type: none"> Turn off the power on the machine and turn it on after a while.
317	XYSlitter response error	<ul style="list-style-type: none"> A problem was detected with the response data from the XY slitter. 	
318	SDcard Connection ERR	<ul style="list-style-type: none"> A problem was detected with the SD card. 	<ol style="list-style-type: none"> Turn off the power on the machine and turn it on after a while.
401	Motor X	<ul style="list-style-type: none"> The X motor was overloaded. 	<ol style="list-style-type: none"> Check to confirm the media is loaded correctly. "Loading the Media"(P. 66) Open the front cover and check for anything that may obstruct carriage movement. Turn off the power on the machine and turn it on after a while.
402	Motor Y	<ul style="list-style-type: none"> The Y motor was overloaded. 	
403	X Current	<ul style="list-style-type: none"> An overcurrent error was detected in the X motor. 	
404	Y Current	<ul style="list-style-type: none"> An overcurrent error was detected in the Y motor. 	
406	Wiper Move Failure	<ul style="list-style-type: none"> The wiper origin could not be detected. 	<ul style="list-style-type: none"> Turn off the power on the machine and turn it on after a while.
44f	Take-up Roll Sns Err	<ul style="list-style-type: none"> A problem was detected with the take-up unit sensor spindle. 	<ol style="list-style-type: none"> Check to confirm the [Function Setting] > [Take-up Unit] setting is "ON". Check to confirm the media is loaded correctly. "Loading the Roll Media"(P. 76) Check to confirm the take-up unit switch functions properly. "Take-up unit"(P. 67)

Error number	Message	Cause	Corrective action
45a	Failed Cutter unit joint	<ul style="list-style-type: none"> The carriage could not be disconnected. 	<ul style="list-style-type: none"> Turn off the power on the machine and turn it on after a while.
45b	Failed Cutter unit detach	<ul style="list-style-type: none"> Unable to connect to carriage 	
45e	Check PR/GR Position	<ul style="list-style-type: none"> A problem was detected with the pinch roller positions. 	<ul style="list-style-type: none"> Place the pinch rollers above the grit rollers.
47f	Take-up Diameter Max	<ul style="list-style-type: none"> The take-up unit media diameter has reached the maximum value. 	<ol style="list-style-type: none"> Replace the paper core in the take-up unit.
48a	Detect winding failure	<ul style="list-style-type: none"> A problem was detected with the take-up unit. 	<ol style="list-style-type: none"> Check to confirm the [Function Setting] > [Take-up Unit] setting is "ON". Check to confirm the media is loaded correctly.  "Loading the Roll Media"(P. 76) Check to confirm the take-up unit switch functions properly.  "Take-up unit"(P. 67)
48b	Y MOTOR COM	<ul style="list-style-type: none"> Y motor communication is not possible. 	<ul style="list-style-type: none"> Turn off the power on the machine and turn it on after a while.
48c	Y MTR I2C COM	<ul style="list-style-type: none"> Y motor communication is not possible at startup. 	
48f	XYSlitter MOTOR X	<ul style="list-style-type: none"> The X motor of the XY slitter was overloaded. 	<ol style="list-style-type: none"> Lower the XY clamp lever (unclamp).  "XY Clamp Lever"(P. 137) Check to confirm the media is loaded correctly.  "Loading the Media"(P. 144) Check to confirm that the XY slitter X cutter is correctly mounted.  "Mounting the X cutter"(P. 151) Raise the XY clamp lever (clamp). <ul style="list-style-type: none"> The origin of the XY slitter will be detected. If the error message "ERROR 315 No resp from XY Slitter" is displayed after origin detection is attempted, take the corrective measure for error 315.
491	XYSlitter X CURRENT	<ul style="list-style-type: none"> An overcurrent was detected in the X motor of the XY slitter. 	
490	XYSlitter MOTOR Y	<ul style="list-style-type: none"> The Y motor of the XY slitter was overloaded. 	
492	XYSlitter Y CURRENT	<ul style="list-style-type: none"> An overcurrent was detected in the Y motor of the XY slitter. 	
493	XYSlitter TBar Abnormal	<ul style="list-style-type: none"> A problem was detected with position control of the XY slitter tension bar. 	<ol style="list-style-type: none"> Lower the XY clamp lever (unclamp).  "XY Clamp Lever"(P. 137) Check to confirm the media is loaded correctly.  "Loading the Media"(P. 144) Raise the XY clamp lever (clamp).
494	XYSlitter TBar Position		
495	XYSlitter TBar Shelter	<ul style="list-style-type: none"> The XY slitter tension bar is still at the retract position. 	<ol style="list-style-type: none"> Lower the XY clamp lever (unclamp).  "XY Clamp Lever"(P. 137) Check to confirm whether the tension bar is at the retract position. Check to confirm the media is loaded correctly.  "Loading the Media"(P. 144) Raise the XY clamp lever (clamp).

Error number	Message	Cause	Corrective action
49f	Slit not detected	<ul style="list-style-type: none"> Slitting feed was performed with guidelines without detecting the slitting marks. 	<ol style="list-style-type: none"> Detect the slitting marks.  "Detecting slitting marks"(P. 161) If the slitting marks cannot be detected (there are no guidelines), perform slitting feed without guidelines.  "Mounting the X cutter and slitting"(P. 164)
496	Y MOTOR DIR	<ul style="list-style-type: none"> The Y motor operating direction cannot be specified. 	<ul style="list-style-type: none"> Turn off the power on the machine and turn it on after a while.
504	CLAMP UP	<ul style="list-style-type: none"> The clamp lever is lifted. 	<ul style="list-style-type: none"> Lower the clamp lever.
505	Media Jam	<ul style="list-style-type: none"> The media jam sensor was triggered. 	<ol style="list-style-type: none"> Remove the media in contact with the carriage and reload with fresh media.  "Loading the Media"(P. 66) Open the front cover and check for anything that may obstruct carriage movement.
509	HDC POSCNT	<ul style="list-style-type: none"> A problem was detected with position control. 	<ul style="list-style-type: none"> Turn off the power on the machine and turn it on after a while.
50a	Y Org Detect Error	<ul style="list-style-type: none"> A problem was detected with Y origin detection (initialization). 	
50c	Check Media With Sensor	<ul style="list-style-type: none"> A problem was detected with media width detection. 	<ol style="list-style-type: none"> Check the media loading position.  "Loading the Media"(P. 66) Clean the media width sensor.  "Media Sensor Cleaning"(P. 205)
50f	L-SCALE BLACK	<ul style="list-style-type: none"> A problem was detected with the linear scale. 	<ul style="list-style-type: none"> Turn off the power on the machine and turn it on after a while.
516	Media Set Position R (L)	<ul style="list-style-type: none"> The media was loaded outside the range of valid positions. 	<ol style="list-style-type: none"> Check the media loading position.  "Loading the Media"(P. 66) Clean the media width sensor.  "Media Sensor Cleaning"(P. 205)
523	Check PR Sensor	<ul style="list-style-type: none"> The pinch roller position detection failed. 	<ul style="list-style-type: none"> Turn off the power on the machine and turn it on after a while.
525	Wrong Ionizer	<ul style="list-style-type: none"> The ionizer internal circuit is defective, or an abnormal discharge occurred. 	<ul style="list-style-type: none"> Turn off the power on the machine and turn it on after a while.
526	Ionizer Ion Level	<ul style="list-style-type: none"> The amount of generated ions was reduced by fouling and abrasion of the electrode needle. 	<ul style="list-style-type: none"> Refer to the instruction manual for the ionizer and clean the electrodes.
527	Ionizer Condition	<ul style="list-style-type: none"> Ambient conditions may cause ions to be absorbed by metals in the vicinity and affect discharge capability. 	<ul style="list-style-type: none"> Remove any conductors or discharge devices close to the ionizer.
528	Pump Motor	<ul style="list-style-type: none"> A problem was detected with the pump motor. 	<ul style="list-style-type: none"> Turn off the power on the machine and turn it on after a while.
546	CLPADJORG SNS	<ul style="list-style-type: none"> The clamp pressure unit origin detection failed. 	





Error number	Message	Cause	Corrective action
54b	Media Press	<ul style="list-style-type: none"> Media retainer detection failed. 	<ol style="list-style-type: none"> Check the media loading position. "Loading the Media"(P. 66) Clean the media width sensor. "Media Sensor Cleaning"(P. 205)
54c	Vacuum Fan Err	<ul style="list-style-type: none"> A problem was detected with the vacuum fan. 	<ul style="list-style-type: none"> Turn off the power on the machine and turn it on after a while.
54d	HDCE Cooling Fan Err	<ul style="list-style-type: none"> An HDCE cooling fan rotation abnormality was detected. 	
54e	UV-LED Fan Err	<ul style="list-style-type: none"> A UV-LED cooling fan rotation abnormality was detected. 	<ul style="list-style-type: none"> Turn off the power on the machine and turn it on after a while.
55A	XYSlitter Y ORIGIN	<ul style="list-style-type: none"> A problem was detected with Y origin detection of the XY slitter. 	<ul style="list-style-type: none"> Turn off the power on the machine and turn it on after a while.
55B	XYSlitter Clamp ON	<ul style="list-style-type: none"> Backward Feed was performed with [MENU] > [Function Setting] > [Finisher] set to [XY Slitter]. The XY clamp lever was left up (clamped) with [MENU] > [Function Setting] > [Finisher] set other than to [XY Slitter]. 	<ul style="list-style-type: none"> Use with the XY clamp lever lowered (unclamped). "XY Clamp Lever"(P. 137)
55C	XYSlitter Clamp OFF	<ul style="list-style-type: none"> The XY clamp lever was left down (unclamped) with [MENU] > [Function Setting] > [Finisher] set to [XY Slitter]. 	<ul style="list-style-type: none"> Use with the XY clamp lever raised (clamped). "XY Clamp Lever"(P. 137)
602	Ink End	<ul style="list-style-type: none"> The ink has run out. 	<ul style="list-style-type: none"> Replace with new ink. "When Ink End is Displayed"(P. 45)
604	Check Waste Ink tank	<ul style="list-style-type: none"> The waste ink tank count exceeded the preset value (80%). 	<ol style="list-style-type: none"> Check the waste ink levels in the waste ink tank. "When "Check Waste Ink Tank" message appears"(P. 242) Replace the waste ink tank, then reset the waste ink level. "Replacing the Waste Ink Tank"(P. 242)
608	Wrong Ink IC	<ul style="list-style-type: none"> An error occurred with the information on the ink IC chip. 	<ol style="list-style-type: none"> Check to confirm the ink IC chip was inserted correctly. "Mounting the ink"(P. 49) Turn off the power on the machine and turn it on after a while. Replace with new ink. "Replacing Ink"(P. 46)
60a	Excess Ink Usage	<ul style="list-style-type: none"> The ink usage amount stored in the ink IC chip exceeded the preset value. 	<ul style="list-style-type: none"> Replace with new ink. "When Ink End is Displayed"(P. 45)

Error number	Message	Cause	Corrective action
		<ul style="list-style-type: none"> The ink IC chip was not replaced during ink replacement. (The same chip continued to be used.) The machine was used with nozzle clogging. 	
60c	Ink Type	<ul style="list-style-type: none"> The ink type registered on the IC chip is different from the ink type filled. 	<ul style="list-style-type: none"> Insert an ink IC chip for the correct ink type.  "Mounting the ink"(P. 49)
61b	Ink supply	<ul style="list-style-type: none"> Ink cannot be supplied. 	<ul style="list-style-type: none"> Turn off the power on the machine and turn it on after a while.
627	Set Eco-cases	<ul style="list-style-type: none"> The ink IC chip could not be read for a certain period of time. 	<ol style="list-style-type: none"> Check to confirm the ink IC chip was inserted correctly. Turn off the power on the machine and turn it on after a while.
629	Expiration Near	<ul style="list-style-type: none"> The ink has expired. 	<ul style="list-style-type: none"> Replace with new ink or use up as quickly as possible. Printing is possible.  "When Ink End is Displayed"(P. 45)
62a	Expiration Over	<ul style="list-style-type: none"> The ink is two months past its expiration date and cannot be used. 	<ul style="list-style-type: none"> Replace with new ink. Printing is not possible.  "When Ink End is Displayed"(P. 45)
631	Ink Color	<ul style="list-style-type: none"> The ink color registered on the IC chip is different from the ink color filled. 	<ul style="list-style-type: none"> Insert an ink IC chip for the correct ink color.  "Mounting the ink"(P. 49)
637	INK LEAK _	<ul style="list-style-type: none"> The ink leak sensor detected an ink leak. 	<ul style="list-style-type: none"> Contact your local distributor, our sales office, or service center.
650	NCU Connect	<ul style="list-style-type: none"> A problem was detected with the NCU connection. 	<ul style="list-style-type: none"> Turn off the power on the machine and turn it on after a while.
651	Replace NCU	<ul style="list-style-type: none"> A problem was detected with the nozzle clogging assessment. 	<ul style="list-style-type: none"> Clean the NCU.  "NCU Cleaning"(P. 200) Replace the NCU if the error does not clear. Contact your local distributor, our sales office, or service center.
652	NCU NzK Chk (Hw)	<ul style="list-style-type: none"> A problem was detected with the nozzle clogging assessment. 	<ul style="list-style-type: none"> Clean the NCU.  "NCU Cleaning"(P. 200)
653	NCU NzK Chk (Mark)		
654	NCU Center Pos		
655	NCU Flush Pos		
656	NCU SN Adjst		
657	Replace NCU Ink Pad	<ul style="list-style-type: none"> The NCU ink absorber is full. 	<ul style="list-style-type: none"> The NCU ink absorber must be replaced. Contact your local distributor, our sales office, or service center.
658	NCU Sensor Lv Low	<ul style="list-style-type: none"> The sensor's sensitivity is impaired. 	<ul style="list-style-type: none"> Clean the NCU.  "NCU Cleaning"(P. 200)

Error number	Message	Cause	Corrective action
65b	NCU Sens Adj Err H	<ul style="list-style-type: none"> • Sensor sensitivity adjustment failed. 	<ul style="list-style-type: none"> • Replace the NCU if the error does not clear. Contact your local distributor, our sales office, or service center.
65c	NCU Sens Adj Err L		
683	Wiper Near End	<ul style="list-style-type: none"> • The remaining amount of cloth wiper is low. 	<ul style="list-style-type: none"> • The cloth wiper will run out soon. Have a new cloth wiper ready.
684	Wiper End	<ul style="list-style-type: none"> • The cloth wiper has run out. 	<ul style="list-style-type: none"> • Replace with a new cloth wiper.  "Cloth Wiper Replacement"(P. 219)
702	Thermistor Connect	<ul style="list-style-type: none"> • A problem was detected with the thermistor connection. 	<ul style="list-style-type: none"> • Turn off the power on the machine and turn it on after a while.
703	Heater Brk	<ul style="list-style-type: none"> • A problem was detected with the heater temperature. 	
706	UV Lamp Temp. High	<ul style="list-style-type: none"> • The UV-LED unit became hot. 	<ul style="list-style-type: none"> • If this occurs frequently, contact your local distributor, our sales office, or service center.
707	Head Heater Break	<ul style="list-style-type: none"> • The head heater is defective. (The temperature does not rise even when heated beyond the stipulated duration.) 	<ul style="list-style-type: none"> • Turn off the power on the machine and turn it on after a while.
70b	DRV OVHT	<ul style="list-style-type: none"> • The UV-DRV PCB became hot. 	
710	Heater Temp Error	<ul style="list-style-type: none"> • A problem was detected with the heater temperature. 	<ul style="list-style-type: none"> • This error will be automatically resolved. If the error is not resolved, Turn off the power on the machine and turn it on after a while.
711	LED OVHT*	<ul style="list-style-type: none"> • The UV-LED PCB became hot. 	<ul style="list-style-type: none"> • Turn off the power on the machine and turn it on after a while.
715	Ink Heater Therm Brk	<ul style="list-style-type: none"> • The ink heater thermistor cannot be read properly. 	
716	Ink Heater Temp	<ul style="list-style-type: none"> • An ink heater temperature abnormality was detected. 	
717	InkHeater Brk	<ul style="list-style-type: none"> • The ink heater is defective. (The temperature does not rise even when heated beyond the stipulated duration.) 	
71a	UV-DRV Fuse	<ul style="list-style-type: none"> • A blown fuse on the UV-DRV PCB was detected. 	<ul style="list-style-type: none"> • The fuse must be replaced. Contact your local distributor, our sales office, or service center.
71e	Head Temp Error	<ul style="list-style-type: none"> • A head temperature abnormality was detected. 	<ul style="list-style-type: none"> • Turn off the power on the machine and turn it on after a while.
71f	Head Therm Break	<ul style="list-style-type: none"> • The head thermistor cannot be read properly. 	
753	Ink Heater Temp (HW)	<ul style="list-style-type: none"> • An ink heater temperature abnormality was detected. 	<ul style="list-style-type: none"> • Turn off the power on the machine and turn it on after a while.

Error number	Message	Cause	Corrective action
754	Ink Heater Temp	<ul style="list-style-type: none"> An ink heater temperature abnormality was detected for a specified time. 	
755	Head Temp Error (HW)	<ul style="list-style-type: none"> A head temperature abnormality was detected. 	
756	Head Temp Error	<ul style="list-style-type: none"> A head temperature abnormality was detected for a specified time. 	
801	(C)OPCODE	<ul style="list-style-type: none"> A problem was detected with the main PCB. 	<ul style="list-style-type: none"> Turn off the power on the machine and turn it on after a while.
802	(C)SWI		
803	(C)PFTCHABRT		
804	(C)DATAABRT		
806	FW/SIO bit	<ul style="list-style-type: none"> A communication error was detected between the boards. 	
808	FW/STP-MTR**	<ul style="list-style-type: none"> A problem was detected with the main PCB. 	
80f	FW/SIO Vch	<ul style="list-style-type: none"> A communication error was detected between the boards. 	
811	FW/SIO read	<ul style="list-style-type: none"> A communication error was detected between the boards. 	
81b	FW/STACK OV	<ul style="list-style-type: none"> A problem was detected with the main PCB. 	
828	PRG ERR L*****		
901	Operation Error	<ul style="list-style-type: none"> The function is disabled due to an error. 	<ul style="list-style-type: none"> Check the error details. <ul style="list-style-type: none"> Media Undetected Ink error Waste ink tank, etc.
902	Data Remain	<ul style="list-style-type: none"> Print (RIP) data was received. 	<ul style="list-style-type: none"> Switch to REMOTE mode and start printing or clear the data and abort printing.
90f	Print Area Short	<ul style="list-style-type: none"> The media is too small for the print. 	<ul style="list-style-type: none"> Replace with wider or longer media. If the printable area is reduced due to a shift in the origin, move the origin to increase the size of the printable area.
b02	PCB CTC	<ul style="list-style-type: none"> The cutter IO PCB could not be detected. 	<ul style="list-style-type: none"> Turn off the power on the machine and turn it on after a while.
b1a	PCB BaseIO	<ul style="list-style-type: none"> A communication error was detected between the boards. 	<ul style="list-style-type: none"> Turn off the power on the machine and turn it on after a while.
b1b	BaseIO PCB Vpow-s	<ul style="list-style-type: none"> A problem was detected with the Base IO PCB power supply. 	
b1c	BaseIO PCB V24		

Error number	Message	Cause	Corrective action
b1e	PCB BaseIO-F**	<ul style="list-style-type: none"> The Base IO PCB fuse blow was detected. 	<ul style="list-style-type: none"> The fuse must be replaced. Contact your local distributor, our sales office, or service center.
b32	INKCT PCB V2R5	<ul style="list-style-type: none"> A problem was detected with the ink supply PCB power supply. 	<ul style="list-style-type: none"> Turn off the power on the machine and turn it on after a while.
b3c	INKCT PCB V3R3		
b36	PCB INKIO	<ul style="list-style-type: none"> A communication error was detected between the boards. 	<ul style="list-style-type: none"> Turn off the power on the machine and turn it on after a while.
b3f	BaseIO Unconform	<ul style="list-style-type: none"> The PCB could not be detected. 	
b42	PCB UVD32B	<ul style="list-style-type: none"> A communication error was detected between the boards. 	<ul style="list-style-type: none"> Turn off the power on the machine and turn it on after a while.
b46	PCB SubIO	<ul style="list-style-type: none"> A communication error was detected between the boards. 	
b47	UVD32B PCB Uvpow	<ul style="list-style-type: none"> A problem was detected with the UVD32B PCB power supply. 	
b48	PCB HDCE*	<ul style="list-style-type: none"> A communication error was detected between the boards. 	<ul style="list-style-type: none"> Turn off the power on the machine and turn it on after a while.
b49	PCB HDCE-VHVFET[12]	<ul style="list-style-type: none"> A problem was detected with the HDCE PCB power supply. 	
b4a	PCB HDCE*-F*	<ul style="list-style-type: none"> A blown fuse on the HDCE PCB was detected. 	<ul style="list-style-type: none"> Contact your local distributor, our sales office, or service center.
b4b	HDCE* PCB V1R2	<ul style="list-style-type: none"> A problem was detected with the HDCE PCB power supply. 	<ul style="list-style-type: none"> Turn off the power on the machine and turn it on after a while.
b4c	HDCE* PCB V2R5		
b4d	HDCE* PCB V3R3		
b4e	PCB SubIO-F*	<ul style="list-style-type: none"> A blown fuse on the SubIO PCB was detected. 	<ul style="list-style-type: none"> The fuse must be replaced. Contact your local distributor, our sales office, or service center.
b4f	SubIO PCB Vpow-s	<ul style="list-style-type: none"> A problem was detected with the SubIO PCB power supply. 	<ul style="list-style-type: none"> Turn off the power on the machine and turn it on after a while.
b50	SubIO PCB FANPOW	<ul style="list-style-type: none"> A problem was detected with the SubIO PCB power supply. 	
b51	BaseIO PCB V24adj	<ul style="list-style-type: none"> A problem was detected with the Base IO PCB power supply. 	<ul style="list-style-type: none"> Turn off the power on the machine and turn it on after a while.
b53	XY slitter No slider PCB	<ul style="list-style-type: none"> The XY slitter CG common slider PCB could not be detected. 	<ul style="list-style-type: none"> Turn off the power on the machine and turn it on after a while.

Error number	Message	Cause	Corrective action
b54	PCB INKIO-F*	<ul style="list-style-type: none"> A blown fuse on the ink PCB was detected. 	<ul style="list-style-type: none"> The fuse must be replaced. Contact your local distributor, our sales office, or service center.
b62	PCB CutterIO-F*	<ul style="list-style-type: none"> A blown fuse on the Cutter IO PCB was detected. 	
C10	Command	<ul style="list-style-type: none"> Received a code other than a COMMAND code. 	<ol style="list-style-type: none"> Clear the data and resend. Check the USB/Ether cable connection.  "Connecting a PC to the Product"(P. 40) Use a compatible cable.  "Connecting a PC to the Product"(P. 40) Turn off the power on the machine and turn it on after a while.
C11	Parameter	<ul style="list-style-type: none"> Received parameter outside numerical value range 	
C12	Device	<ul style="list-style-type: none"> Received an invalid device control command. 	
C31	No Data	<ul style="list-style-type: none"> "COPY" was executed, but no data is saved to the receive buffer. 	<ul style="list-style-type: none"> Transmit the same data once more.
C32	DataTooBig	<ul style="list-style-type: none"> The received data is too big for multiple sheet cutting. 	<ul style="list-style-type: none"> Change the data size.
C33	Sheet Size	<ul style="list-style-type: none"> The sheet is too short in the feed direction. 	<ul style="list-style-type: none"> Use a longer sheet.
C36	Mark Detect	<ul style="list-style-type: none"> Unable to detect register marks 	<ol style="list-style-type: none"> Check to confirm the register marks are placed properly.  "Register Marks"(P. 124) Load the uncurled media. Check the mark detection start position. Check to confirm the register marks are black and printed on a white background. Check to confirm the area between the register marks is clean and free of print. Check to confirm there are no errors in the mark detection settings. If the area around the register marks is filled in, set [Mark Detect] > [Mark FillUp] setting to "ON".
C37	Mark Org	<ul style="list-style-type: none"> The mark detection result shows that the register marks were detected outside the plotting range. 	<ul style="list-style-type: none"> Change the layout by referring to the following:  "Reading Range of Register Marks"(P. 127)
C38	Register mark scale	<ul style="list-style-type: none"> Unable to detect register marks 	<ol style="list-style-type: none"> Check to confirm the register marks are placed properly.  "Register Marks"(P. 124) Load the uncurled media. Check the mark detection start position. Check to confirm the register marks are black and printed on a white background. Check to confirm the area between the register marks is clean and free of print. Check to confirm there are no errors in the mark detection settings.

Error number	Message	Cause	Corrective action
			7. If the area around the register marks is filled in, set [Mark Detect] > [Mark FillUp] setting to "ON".
C60	PenEncoder	<ul style="list-style-type: none"> Unable to detect pen height. 	<ul style="list-style-type: none"> Turn off the power on the machine and turn it on after a while.
C61	Pen Stroke	<ul style="list-style-type: none"> The pen height is incorrect. 	<ol style="list-style-type: none"> Make sure the pen line rubber is not worn or deformed and remains intact. Check to confirm nothing adheres to the pen line rubber. After installing the pen in a commercially available pen holder, check to confirm the installed position is correct.
C63	Cutter Head	<ul style="list-style-type: none"> The cutter vertical movement is slow. 	<ul style="list-style-type: none"> Turn off the power on the machine and turn it on after a while.
d1b	COM VOLT[12]	<ul style="list-style-type: none"> A problem was detected with the HDCE PCB voltage. 	<ul style="list-style-type: none"> Turn off the power on the machine and turn it on after a while.

SYSTEM HALT



- If a SYSTEM HALT number is displayed, Turn off the power on the machine and turn it on after a while.

Chapter 9 Appendix



This chapter

This chapter describes the machine specifications.

Specifications	280	Options	286
Specifications (Cutting)	284	Relay Box.....	287
Specifications (XY Slitter).....	285	Ionizer	288
		Static-Cling Prevention Sheet Kit.....	291
		Deodorizing fan unit	294
		Proofing Light.....	300
		UCJV330 Heater Unit	302
		TP Ink Heater Unit	305
		LICENSE Library	308



9.1 Specifications

Item		JV330 Series	CJV330 Series	UCJV330 Series	TS330-1600
Print head	Type	On-demand piezo head			
	Specifications	Two staggered heads with 400 nozzles × 8 rows each			
	Resolution	Y	600 dpi, 1,200 dpi	600 dpi, 1,200 dpi	300 dpi, 600 dpi
X		600 dpi, 900 dpi, 1,200 dpi	600 dpi, 1,200 dpi, 1,800 dpi	600 dpi, 900 dpi, 1,200 dpi	
Ink Type		SS21, BS4	LUS-170/175, LUS-200, LUS-190/210	Sb411, TP410 ^{*1}	
Ink set	4-color	C, M, Y, K (UISS)	C, M, Y, K	BL, M, Y, K (UISS)	
	6-color, W	C, M, Y, K, Lc, Lm, W	-	-	
	8-color	C, M, Y, K, Lc, Lm, Lk, Or	-	C, M, Y, K, R, Gr, BL, Lk	
	6-color	-	-	BL, M, Y, K, Lbl, Lm (Y, K: UISS)	
	7-color	-	-	BL, M, Y, K, Lbl, Lm, Lk (Y: UISS)	
	4-color, FP, FY	-	-	BL, M, Y, K, FP, FY (BL, M: UISS)	
	6-color, FP, FY	-	-	BL, M, Y, K, Lbl, Lm, FP, FY	
	4-color, W, CI	-	-	C, M, Y, K, W, CI	
	4-color, W	-	-	C, M, Y, K, W	
Media	Type ^{*2}	Label paper (paper base), PVC sheet (not more than 0.25 mm in thickness, including laminating layer), fluorescent sheet, reflective sheet (UCJV: excluding high-luminosity reflective sheet), window film, tarpaulin			Transfer paper
	Maximum printing width ^{*3}	160 size: 1,610 mm 130 size: 1,360 mm			1,610 mm
	Maximum width	160 size: 1,620 mm 130 size: 1,370 mm			1,620 mm
	Minimum width	210 mm			
	Thickness	Max. 1.0 mm			
	Roll external diameter ^{*4}	Paper media: Max. 250 mm Other media: Max. 210 mm			Max. 250 mm ^{*5}
	Roll weight ^{*4, 6}	Max. 45 kg per roll Three rolls (feeding unit): Max. 90 kg			Max. 45 kg
	Paper core internal diameter ^{*7}	2 inches or 3 inches			
	Printing face	Exterior/interior			Exterior
	Roll end	Taped or loosely affixed to paper core			

Item		JV330 Series	CJV330 Series	UCJV330 Series	TS330-1600
Print margins	Left/right	15 mm (default), minimum: Left/right 5 mm			
	Top end	70 mm (default), minimum: Left/right 10 mm			
	Bottom end	70 mm (default), minimum: Left/right 10 mm			
Distance accuracy ^{*8}	Absolute accuracy	±0.3 mm or ±0.3 % of specified distance, whichever is greater			
	Duplicability	±0.2 mm or ±0.1 % of specified distance, whichever is greater			
Perpendicularity		±0.25 mm/1,000 mm			
Media skew		Not more than 2.5 mm/10 m			
Printing gap		Manual, three settings (2.0, 2.5, 3.0 mm)			Manual, three settings (3.0, 3.5, 4.0 mm)
Clamp pressure		Auto switch (three settings)	Auto switch (four settings) ^{*9}		Auto switch (three settings)
Media cutting		Cutting precision (steps): Not more than 1.0 mm ^{*10}			
Origin alignment		LED pointer			
Ink supply		Ink eco-case (ink pack)		Ink bottle	Ink eco-case (ink pack)
Maintenance liquid feed		Cartridge		-	Cartridge
Waste Ink Tank		Bottle type (2,000 ml)			
Take-up unit		Selectable inside/outside winding			
Media heater		PRE, PRINT, POST (Independent control)		PRE	POST/PRINT, POST (Only when using TP410 ^{*1})
NCU (Nozzle clogging detection)		Provided			
DAS (Automatic correction function)		Provided			
Interior lighting		Provided			
UV unit		-		Air-cooled LED UV emitters x2	-
Interface	Data transfer function	Ethernet 1000BASE-T (recommended) ^{*11, 12} , USB 2.0 Hi-speed ^{*12, 13}			
Command		MRL-V			
Languages		English, Japanese, Chinese, Turkish, Portuguese, Spanish, Italian, Korean			
Noise levels	During standby	Not more than 45 dB (FAST-A, 1 m on all sides)			
	Continuous operation	Not more than 59 dB (FAST-A, 1 m on all sides)			
	Non-continuous operation	Not more than 65 dB (FAST-A, 1 m on all sides)			

Item		JV330 Series	CJV330 Series	UCJV330 Series	TS330-1600
Compliance with standards		VCCI Class A, FCC Class A, IEC 62368-1 ETL compliance, CE marking (EMC Directive, Low Voltage Directive, Machinery Directive, RoHS Directive), CB certified, REACH, EnergyStar, RCM marking, KC certified, UKCA marking			
Power supply specifications ^{*14}		Single-phase 100 to 120 V AC $\pm 10\%$ /12 A, single-phase 200 to 240 V AC $\pm 10\%$ /6 A, 50/60 Hz ± 1 Hz $\times 2$		Single-phase 100 to 120 V AC $\pm 10\%$ /12 A, single-phase 200 to 240 V AC $\pm 10\%$ /6 A, 50/60 Hz ± 1 Hz $\times 1$	
Power consumption	Maximum ^{*15}	Inlet 1	100 to 120 V AC: Max. 1,440 W 200 to 240 V AC: Max. 1,440 W		
		Inlet 2	100 to 120 V AC: Max. 1,440 W 200 to 240 V AC: Max. 1,440 W	-	100 to 120 V AC: Max. 1,440 W 200 to 240 V AC: Max. 1,440 W (Only when using TP410 ^{*1})
	Standard	Inlet 1	800 W		
		Inlet 2	750 W	-	400 W (Only when using TP410 ^{*1})
	Minimum ^{*16}	Inlet 1	4.5 W or less		
		Inlet 2	----	-	-
Installation environment ^{*17}	Permissible ambient temperature	20 to 30 °C			
	Relative humidity	35 to 65 %RH (no condensation)			
	Temperature range in which accuracy is guaranteed	20 to 25 °C			
	Temperature gradient	Not more than ± 10 °C/h			
	Dust	0.15 mg/m ³ (typical office)			
	Maximum operating altitude	2,000 m			
External dimensions ^{*18}	Width	160 size: 3,170 mm (3,550 mm) 130 size: 2,920 mm (3,300 mm)		160 size: 2,890 mm (3,550 mm) 130 size: 2,640 mm (3,300 mm)	3,170 mm (3,550 mm)
	Depth	1,215 mm ^{*19} (1,130 mm)		805 mm (1,130 mm)	820 mm (1,130 mm)
	Height	1,305 mm (950 mm)		1,480 mm ^{*20} (950 mm)	1,305 mm (950 mm)
Weight ^{*16}	160 size	368 kg (460 kg)	373 kg (468 kg)	227 kg (310 kg)	240 kg (300 kg)

Item	JV330 Series	CJV330 Series	UCJV330 Series	TS330-1600
130 size	358 kg (453 kg)	363 kg (458 kg)	217 kg (300 kg)	-

- *1. The OPT-J0562 "TP-Ink Heater Unit 1600" option must be installed when using the TP410 ink set.
- *2. The XY slitter is limited to the types of media that can be used with it.  ["Specifications \(XY Slitter\)"\(P. 285\)](#)
- *3. With setup menu margins set to the minimum (5 mm) on either side.
- *4. External diameter and weight after winding media.
- *5. 120 to 200 mm when the (take-up unit) media edge guide is used (depending on the position of the edge guide).
- *6. Free of sagging due to weight.
- *7. 3 inch only for high-speed printing.
- *8. Excluding media size variation and initial loading fluctuations.
- *9. Partial switch supported. Including clamp off.
- *10. Excluding V-shaped cutting.
- *11. Printing is not possible if local guidance shows any speed other than "1000Mbps".  ["Using a LAN Cable"\(P. 40\)](#)
- *12. The print speed may be decreased depending on the connection environment or print data.  ["Connecting a PC to the Product"\(P. 40\)](#)
- *13. Data may be transferred to the machine too slowly, causing the carriage to pause at the left-hand or right-hand end during printing.
- *14. Excluding options.
- *15. Varies depending on print mode.
- *16. In sleep.
- *17. Ink ejection consistency may decrease in conditions outside this range.
- *18. The figures in parentheses indicate package dimensions. Excluding the external supply unit.
- *19. Excluding the media chute.
- *20. Excluding the ink bottles.

9.2 Specifications (Cutting)

Item	Details
Maximum speed ^{*1}	300 mm/s (420 mm/s at 45 °)
Maximum acceleration	0.5 G
Cut pressure	10 to 450 gf
Cutter response count	10 times/second
Usable tools	Eccentric cutter, ballpoint pen (commercially sold) ^{*2}
Usable media	Label paper (paper base), PVC sheet ^{*3} (not more than 0.25 mm in thickness, including laminating layer), fluorescent sheet ^{*4} , reflective sheet ^{*4} (excluding high-luminosity reflective sheet)
Repetition accuracy	±0.2 mm or less (excluding expansion and contraction due to temperature)
Receive buffer memory	32 MB
Command	MGL-II c2
Program steps	25 μm/step

*1. Depending on media size, the maximum speed may be limited. It is not possible to operate at both maximum speed and maximum acceleration.

*2. Use one free of protrusions and tapers on the clamped part. Depending on the ballpoint pen, optimal image quality may not be possible.

*3. When using Mimaki Engineering specified sheet

*4. When using fluorescent sheet blade (SPB-0007) or reflective sheet blade (SPB-0006)

9.3 Specifications (XY Slitter)

Item		Details
Cutting accuracy ^{*1}	X slit	Within ± 2 mm/2 m or ± 5 mm/30 m
	Y slit	Within ± 2 mm
Cutter blade durability	X	4000 m or more
	Y	5500 m or more
Media	Type ^{*2, 3}	Label paper (paper base), PVC sheet, window film
	Thickness	Max. 1.0 mm
	Maximum cutting width	130 size: 1,310 mm 160 size: 1,560 mm
	Minimum cutting width	210 mm (horizontally) \times 297 mm (vertically)
	Left/right margins	Minimum values: Left 25 mm, right 35 mm
	Margin between cut data	Minimum values: X 62 mm, Y 30 mm

*1. Excluding media size variation and fluctuations at initial loading.

*2. Low stiffness media cannot be used.

*3. Tarpaulin and laminated media cannot be used.

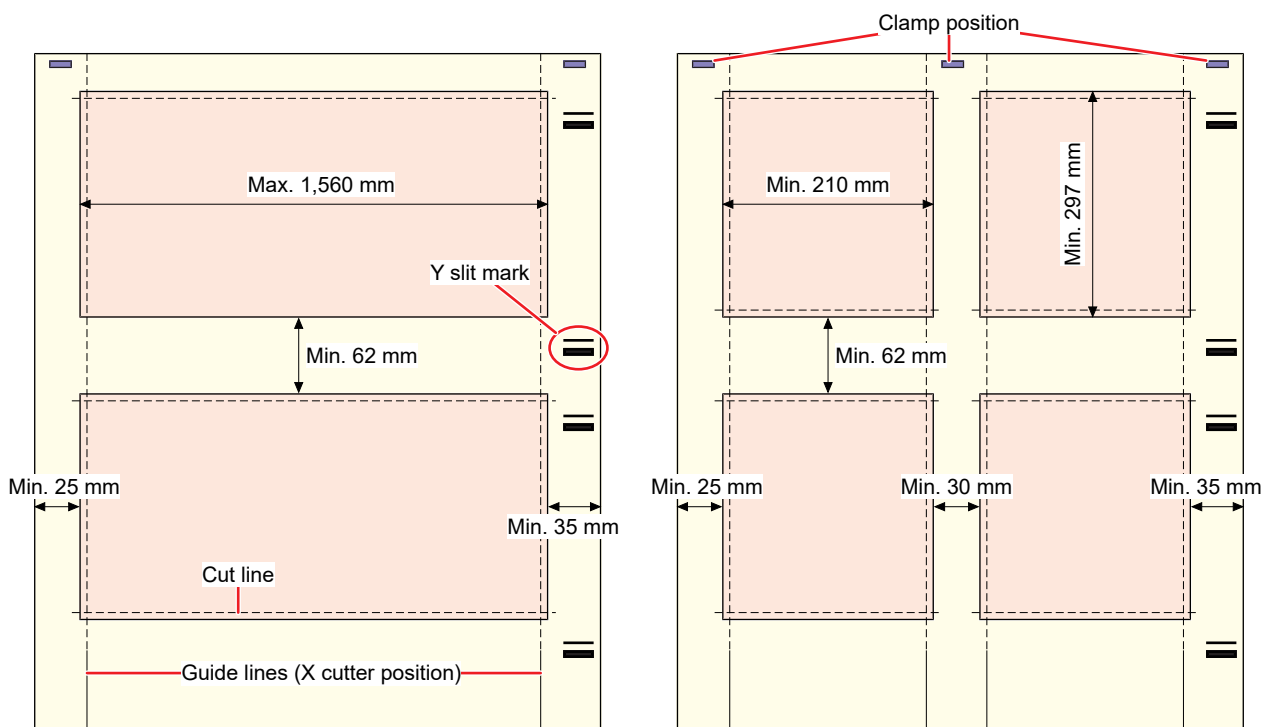

9.4 Options

● Compatibility table

Name	Code	JV	CJV	TS	UCJ V	Reference page
Small Relay Box	OPT-J0370	○	○	○	○	"Relay Box"(P. 287)
Relay Box 2	OPT-J0407	○	○	○	○	"Relay Box"(P. 287)
XY slitter	160: OPT-J0558 130: OPT-J0559	Standard	Standard	-	○	"Using the XY Slitter"(P. 135)
X Slitter Unit	OPT-J0532	○	○	-		"X Cutter"(P. 138)
Media Changer	160: OPT-J0556 130: OPT-J0557	Standard	Standard	-	○	"Media Changer"(P. 74)
Media Edge Guides	OPT-J0553	○	○	Standard	○	"Media Edge Guide Film Replacement"(P. 239)
10 kg ink supply unit	OPT-J0529	-	-	○	-	Separate operating manual (D203605)
T Bar 1600 Unit	OPT-J0530	-	-	○	-	Separate operating manual (D203635)
Mini Jumbo Unit	OPT-J0477	-	-	○	-	Separate operating manual (D203635)
Electrical Box (for Mini-Jumbo)	OPT-J0480	-	-	○	-	
Ionizer	160: OPT-J0545 130: OPT-J0546	○	○	-	○	"Ionizer"(P. 288)
Static-Cling Prevention Sheet Kit	160: OPT-J0549 130: OPT-J0550	○	○	-	○	"Static-Cling Prevention Sheet Kit"(P. 291)
Deodorizing fan unit	160: OPT-J0540 130: OPT-J0541	○	○	-	○	"Deodorizing fan unit"(P. 294)
Proofing Light	160: OPT-J0547 130: OPT-J0548	-	-	-	○	"Proofing Light"(P. 300)
UCJV330 Heater Unit	160: OPT-J0560 130: OPT-J0561	-	-	-	○	"UCJV330 Heater Unit"(P. 302)
TP Ink Heater Unit	TS330-1600: OPT-J0562	-	-	○	-	"TP Ink Heater Unit"(P. 305)

Relay Box



- A fire may occur if another manufacturer's external drying heater is used. Be sure to connect to the machine using either the compact relay box or relay box 2 specified as options.



- The 330 Series allows only one relay box (OPT-J0370 or OPT-J0407) to be connected.



- The optional connection relay cable (OPT-J0512 drying fan connection kit) is required when using a relay box.

● Overview

The relay box switches the heater power on and off automatically in conjunction with the machine operations.

- The heater is turned off when printing stops to prevent heating while the machine is not moving.
- The relay box cannot function to control the temperature of an external drying heater. The temperature should be set on the external heater itself.

● Specifications

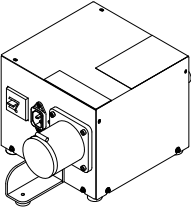
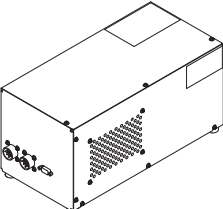
Small relay box (OPT-J0370) 	Power supply specifications	Single-phase 100 V to 120 V AC, 12 A, single-phase 200 V to 240 V AC, 8 A, 50/60 Hz, single-circuit main power supply
	Type	Resistance heater or electric heater using lamp
Relay box 2 (OPT-J0407) 	Power supply specifications	Single-phase 100 V to 240 V AC, 30 A, 50/60 Hz, single-circuit main power supply
	Type	Resistance heater or electric heater using lamp

Ionizer

JV
CJV
UCJV

Be sure to read and understand the following information before use.

● Before use

- The machine prints while the ionizer removes static electricity from media. The electrode probes are not on unless the machine is printing.
- May not be sufficiently effective in removing static electricity in certain environments or for certain media.
- We recommend checking to ensure that static electricity has been sufficiently removed before use.



- Make sure you fully understand the following details. The same precautions apply to optional items.

- (1) ["Introduction"\(P. 7\)](#)
- (2) ["To Ensure Safe Use"\(P. 9\)](#)
- (3) ["Installation Precautions"\(P. 18\)](#)



- This is a high-voltage device. Avoid exposure to substances such as water, oil, or flammable solvents. Failure to follow this precaution may cause insulation breakdown and pose a risk of mechanical failure or electric shock.



- Keep metal objects and body parts such as face and hands away from the ionizer. This may pose a risk of failure or electric shock.
- Always use ventilation. If the ionizer is used in an enclosed area, the ozone generated may be harmful.
- Do not touch the electrode probes with tools or other hard objects. This may pose a risk of failure or electric shock.
- Clean periodically. As the ionizer is used, dust, ink, and the like will adhere to the electrode probes. Continuing to use the ionizer in this state may make it less effective at removing static electricity and may result in failure or electric shock.
- Never attempt to repair the machine yourself, which is hazardous. This may pose a risk of failure or electric shock. In case of abnormalities, contact your local dealer or our service office.



- Do not use where the temperature may change suddenly or where condensation may occur.
- Do not use for purposes other than removing static electricity.



- Be careful not to touch the electrode probes. There is a risk of injury from the tips, which are sharp.

Using the Ionizer

● Enable use of the ionizer

- 1** On the LOCAL mode screen, select [MENU] > [Function Setting], then press the [ENTER] key.
 - The Function Setting menu is displayed.
- 2** Select [Ionizer] > [ON], then press the [ENTER] key.

● How to use

Tilt the ionizer on the back of the printer so that it rests at the stopping position.

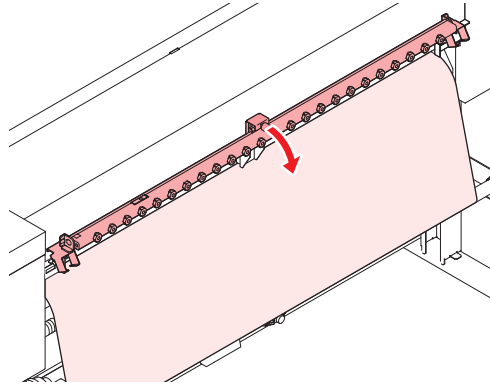

● Maintenance

Before printing, examine the electrode probes and clean off any dirt.



- Turn off the main power supply and unplug the power cable before carrying out maintenance.

1 Remove the electrode probes from the ionizer.

- Using the included replacement kit enables easy removal.



2 Wipe off the electrode probes and the area around them with a cotton swab soaked in alcohol.

- Recommended: Ethyl alcohol, isopropyl alcohol



- Use an ultrasonic bath if especially dirty. Industrial alcohol can also be used as a cleaning solution.



- After cleaning, dry well before reattaching to the ionizer. Any liquid remaining on the probes may cause failure or electric shock.

Ionizer indicator light (alarm function)

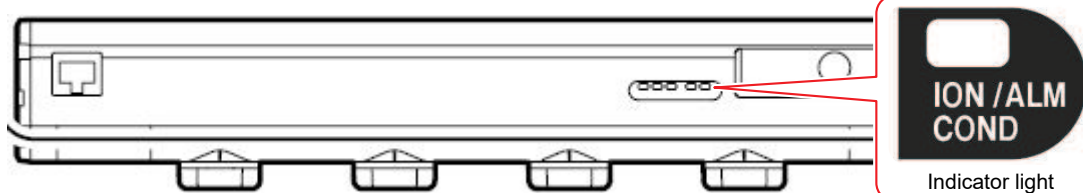

Indicator light	Ionizing status	Error display	Cause	Corrective action
Flashes three times every second	Stopped	Error 525 Wrong Ionizer	<ul style="list-style-type: none"> Defective internal circuit. Abnormal electrical discharge. 	<ul style="list-style-type: none"> Contact your local dealer or our service office.
Flashes about twice per second	Continuous	Error 526 Ionizer Ion Level	<ul style="list-style-type: none"> Lower ion generation due to fouling or abrasion of the electrode probes. This is a sign that electrode probe cleaning is needed. 	<ul style="list-style-type: none"> Clean the electrode probes. If the problems persist, replace the corresponding probes. <ul style="list-style-type: none"> SPA-0208 replacement tungsten probes for ionizer (includes 4)
Flashes about once per second	Continuous	Error 527 Ionizer Condition	<ul style="list-style-type: none"> Removal of static electricity has been affected by the installation environment (temperature, humidity, nearby metal, etc.). 	<ul style="list-style-type: none"> Investigate the environment and nearby metal.

Static-Cling Prevention Sheet Kit

JV
CJV
UCJV

● Kit contents

- 160 size
 - Electrostatic sheets: 4, brackets: 4, springs: 12, adhesive tape
- 130 size
 - Electrostatic sheets: 3, brackets: 3, springs: 9, adhesive tape

● When using an electrostatic sheet (loading instructions)

- 1** Hook the tab of the antistatic sheet onto the bracket and pull downward slightly.

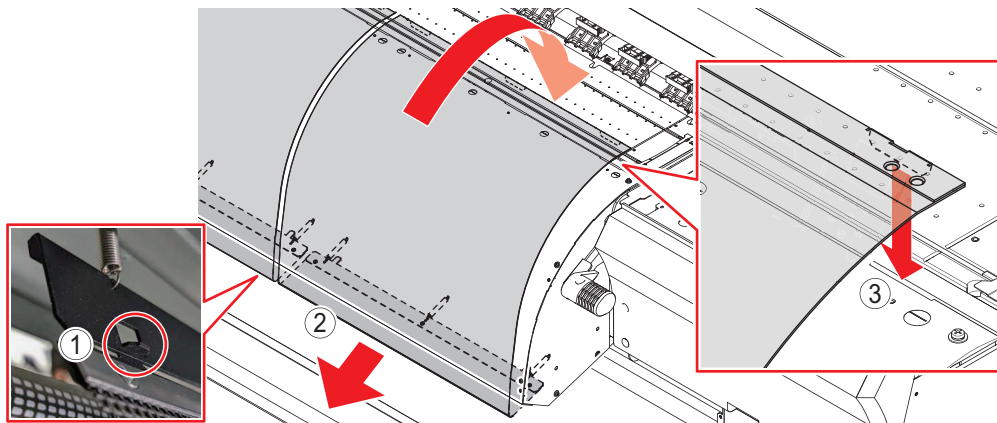

- 2** Keep the sheet taut as you bring it to the front of the platen.
- 3** Hook the tab into the groove in front of the platen.
 - There are three tabs on the sheet.
- 4** Make sure the sheet bracket is magnetically held to the bottom of the post-heater.



5 Apply adhesive tape over the platen and sheet.

- When applying the tape, make sure it does not extend over the platen cutting slot.
- Avoid wrinkles or slack in the tape as you apply it from one end of the platen to the other.

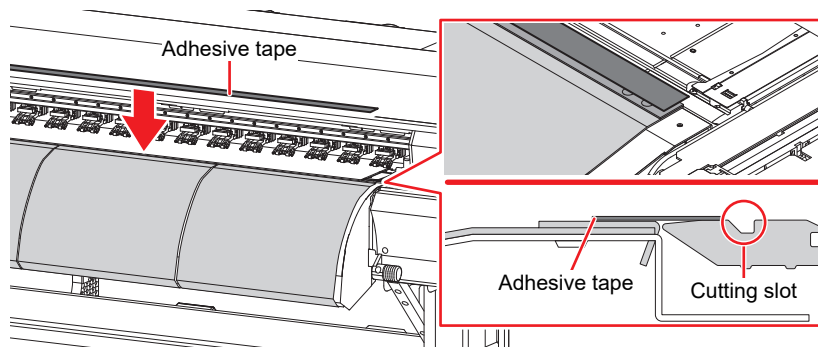

● When the sheet will not be used (unloading instructions)

1 Remove the sheet from the bracket attached to the bottom of the printer.

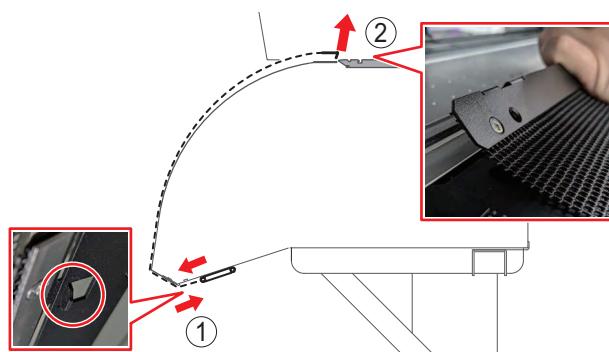

2 Push the sheet toward the platen as you remove it.

- After removing the sheet from the machine, store it separately in a safe place.
- Leave the bracket magnetically attached to the bottom of the post-heater.



Troubleshooting

● Spring and brackets have come off.

Attach from the back of the printer.

- 1 Remove the spring from the printer.

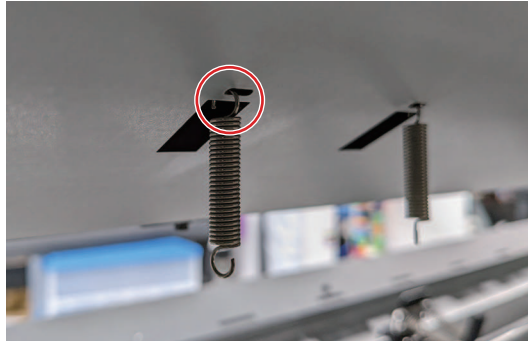

- 2 Reattach the spring to the bracket.



- 3 Reattach to the printer.

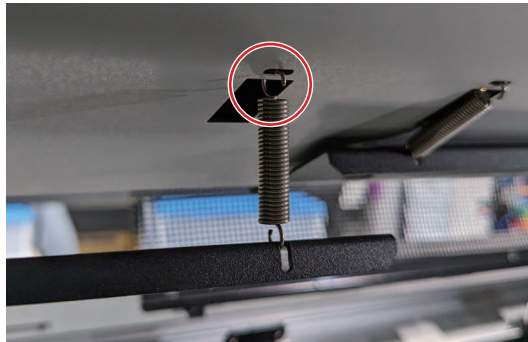

Deodorizing fan unit

JV

CJV

UCJV

Be sure to read and understand the following information before use.

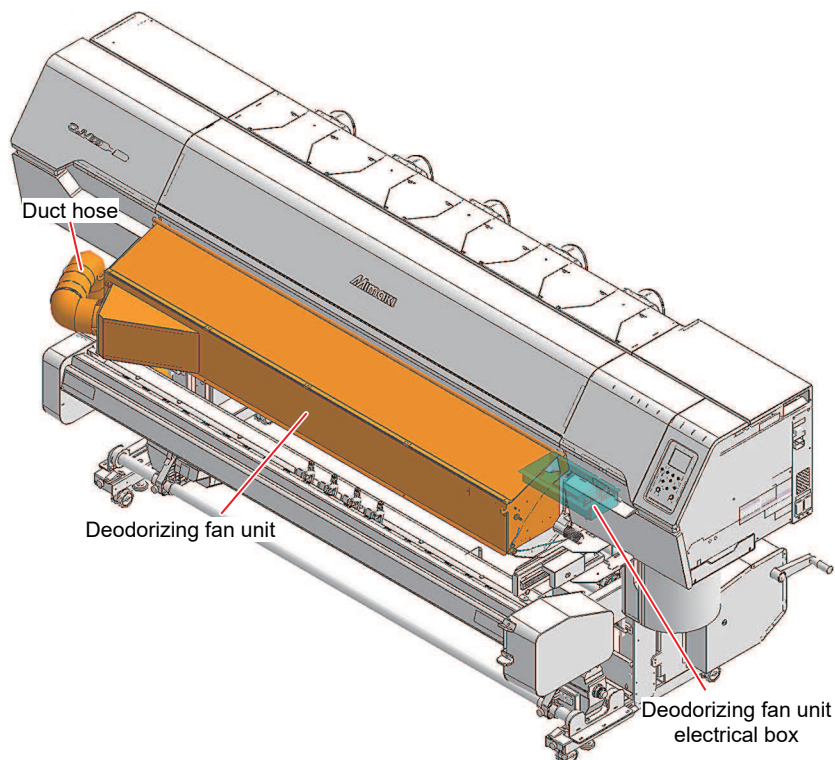

● Before use

- The filter should be replaced approximately once a year. Replace the filter sooner if a large amount of ink has accumulated on it.
- When opening the left-hand maintenance cover, either adjust the angle of the duct hose or remove the duct hose.
 - Removing the duct hose ["Using the deodorizing fan unit"\(P. 296\)](#)

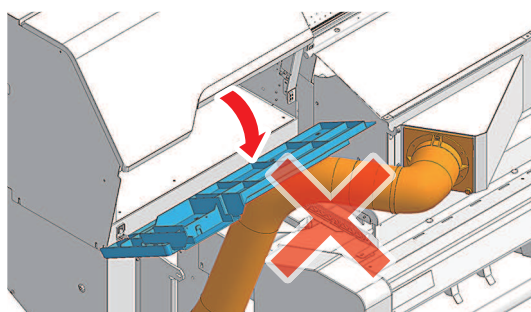

- (CJV/UCJV) Pull the media to the front slightly before starting cutting.
- The duct hose extends to a maximum length of approximately 3 m.



- Make sure you fully understand the following details. The same precautions apply to optional items.
 - (1) ["Introduction"\(P. 7\)](#)
 - (2) ["To Ensure Safe Use"\(P. 9\)](#)
 - (3) ["Installation Precautions"\(P. 18\)](#)



- This is a high-voltage device. Avoid exposure to substances such as water, oil, or flammable solvents. Failure to follow this precaution may cause insulation breakdown and pose a risk of mechanical failure or electric shock.



- Use the power cable provided. Otherwise there is a risk of deodorizing fan unit failure, electric shock, or fire. The power cable cannot be used with electrical equipment other than the deodorizing fan unit.
- Never attempt to repair the machine yourself, which is hazardous. This may pose a risk of failure or electric shock. In case of abnormalities, contact your local dealer or our service office.
- Perform the following when turning off power:
 - (1) Turn off the power to the printer.
 - (2) Turn off the power to the deodorizing fan unit.
 - (3) Disconnect all of the power cables connected to the printer.
 - (4) Unplug the deodorizing fan unit power cable from the power outlet.



- Do not use where the temperature may change suddenly or where condensation may occur.



- A number of different power cables are provided with the product. Use the power cable to suit the region where used.

Japan	China	North America, Central America	Europe	Argentina
Rated input: 15 A, 125 V Type: B	Rated input: 10 A, 250 V Type: D	Rated input: 15 A, 125 V Type: B	Rated input: 10 A, 250 V Type: D	Rated input: 10 A, 250 V Type: D



- The end of the duct hose is extremely sharp. Always wear gloves.



● Warning Label

Make sure you fully understand the details indicated on the various warning labels.

If any of the warning labels becomes dirty and illegible or peel off, contact your local dealer or our service office to request new warning labels.

No.	Order code	Label	Details
1	M911354		Unplug all of the power cables when turning off the power.

- Check the power cable connection

- 1 Check to confirm that the power cable is connected to the deodorizing unit inlet.

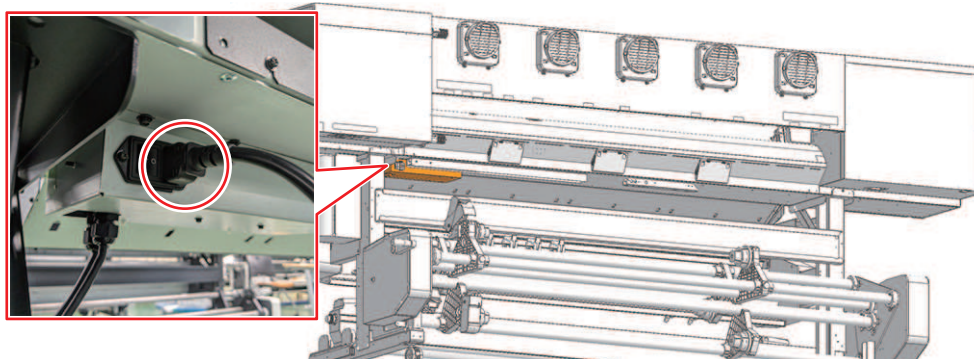

- 2 Check to confirm that the power plug is connected to the power outlet.

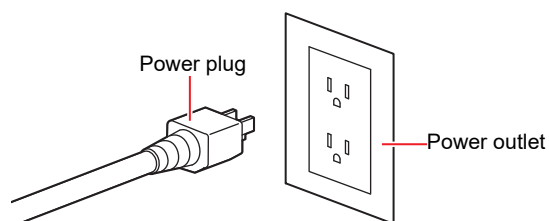

- Do not handle the power plug with wet hands. Disregarding this precaution may result in electric shock.

- Check the main unit connection

- 1 Check to confirm that the cable (D-sub) is connected to the printer.

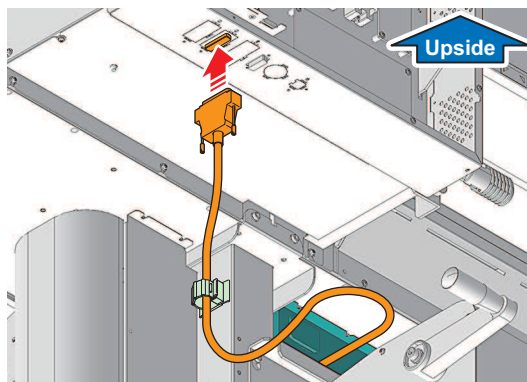

Using the deodorizing fan unit

- Enable the deodorizing fan unit

- 1 On the LOCAL mode screen, select [MENU] > [Function Setting], then press the [ENTER] key.
 - The Function Setting menu is displayed.
- 2 Select [Drying/Exhaust Fan] > [ON], then press the [ENTER] key.
 - "Function Setting Menu"(P. 182) P. 183

● Adjust the deodorizing level

Adjust the deodorizing level to suit the usage environment, the type of media, and the print data.

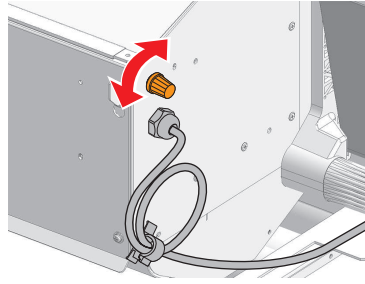

● Extend the deodorizing time

The deodorizing fan operates while printing is in progress. Set as follows to operate the deodorizing fan even after printing has ended:

- 1** On the LOCAL mode screen, select [MENU] > [Function Setting], then press the [ENTER] key.
 - The Function Setting menu is displayed.
- 2** Select [Drying/Exhaust Fan] > [Stop Time], then set the time until it stops.
 - "Function Setting Menu"(P. 182) P. 183

● Operating the deodorizing fan when printing is not in progress

Set as follows to operate the deodorizing fan when printing is not in progress:

- 1** On the LOCAL mode screen, select [MENU] > [Function Setting], then press the [ENTER] key.
 - The Function Setting menu is displayed.
- 2** Select [Drying/Exhaust Fan] > [ON/OFF].
 - "Function Setting Menu"(P. 182) P. 183

● Using the roll screen

Using the roll screen when printing can help to prevent odors spreading.

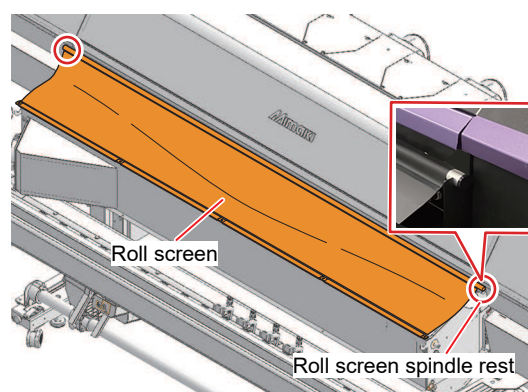

When not in use, the roll screen can be rolled up and stowed at the front.

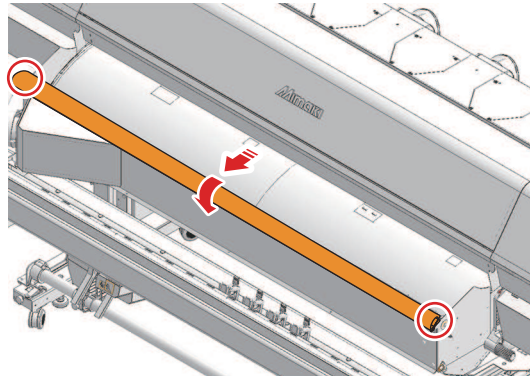

● Removing the duct hose

1 Remove the plastic point screw.

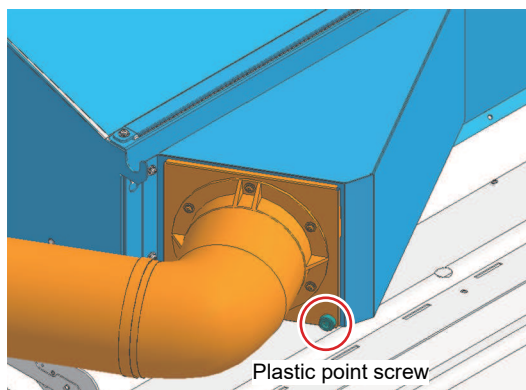

2 Detach the slots, and slowly remove the duct hose.

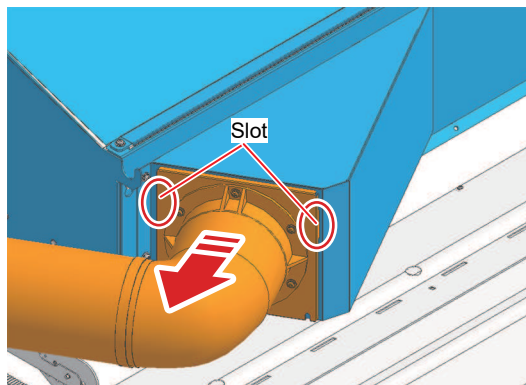

Specifications (deodorizing fan unit)

Item			160 size	130 size
Power supply specifications			Single-phase 100 to 240 V AC $\pm 10\%$ /1.4 A, 50/60 Hz ± 1 Hz	
Power consumption	Max	Inlet	100 to 120 V AC: Max. 140 W, 200 to 240 V AC: Max. 140 W	
	Standard	Inlet	50 W	
External dimensions ^{*1, 2}	Width		1,915 mm (1,980 mm)	1,650 mm (1,980 mm)
	Depth		400 mm (325 mm)	
	Height		270 mm (285 mm)	
Weight ^{*1}			20 kg (21 kg)	19 kg (20 kg)

*1. The figures in parentheses indicate package dimensions.

*2. Excluding the duct hose.

Proofing Light

UCJV

Be sure to read and understand the following information before use.

● Before use



- Make sure you fully understand the following details. The same precautions apply to optional items.

- (1) "Introduction"(P. 7)
- (2) "To Ensure Safe Use"(P. 9)
- (3) "Installation Precautions"(P. 18)



- This is a high-voltage device. Avoid exposure to substances such as water, oil, or flammable solvents. Failure to follow this precaution may cause insulation breakdown and pose a risk of mechanical failure or electric shock.



- Use the power cable provided. Otherwise there is a risk of proofing light failure, electric shock, or fire. The power cable cannot be used with electrical equipment other than the proofing light.
- Never attempt to repair the machine yourself, which is hazardous. This may pose a risk of failure or electric shock. In case of abnormalities, contact your local dealer or our service office.



- Do not use where the temperature may change suddenly or where condensation may occur.



- A number of different power cables are provided with the product. Use the power cable to suit the region where used.

Japan	China	North America, Central America	Europe	Argentina
Rated input: 15 A, 125 V Type: B	Rated input: 10 A, 250 V Type: D	Rated input: 15 A, 125 V Type: B	Rated input: 10 A, 250 V Type: D	Rated input: 10 A, 250 V Type: D

● Check the AC adapter connection

- 1 Check to confirm that the AC adapter plug is connected to the DC jack.
- 2 Check to confirm that the power plug is connected to the power outlet.

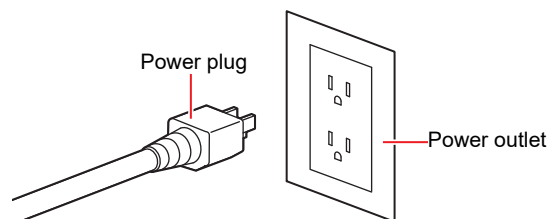

- Do not handle the power plug with wet hands. Disregarding this precaution may result in electric shock.

Using the proofing light

1 Turn on the power to the light

- Turn the power switch to "I".

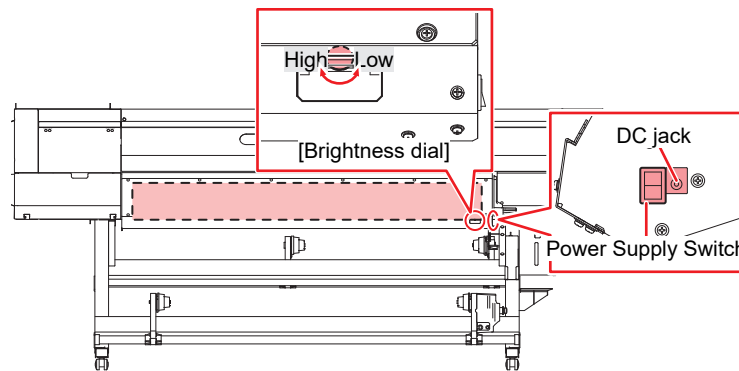

2 Adjust the brightness.

- Turn the "Brightness dial" to the right of the proofing light to adjust the brightness.



- To adjust the brightness while printing is in progress, load the media so that it does not cover the "Brightness dial".  ["Loading the Media"\(P. 66\)](#)

● Maintenance

Clean if it becomes dirty.



- Turn off the main power supply and unplug the power cable before carrying out maintenance.



- Be careful to prevent liquids from getting inside the machine. Otherwise there is a risk of failure, electric shock, or fire.



- For heavy soiling, wipe using a soft cloth soaked in diluted neutral detergent and thoroughly wrung out.

UCJV330 Heater Unit

UCJV

Be sure to read and understand the following information before use.

● Before use



- Make sure you fully understand the following details. The same precautions apply to optional items.
 - (1) "Introduction"(P. 7)
 - (2) "To Ensure Safe Use"(P. 9)
 - (3) "Installation Precautions"(P. 18)



- This is a high-voltage device. Avoid exposure to substances such as water, oil, or flammable solvents. Failure to follow this precaution may cause insulation breakdown and pose a risk of mechanical failure or electric shock.



- Use the power cable provided. Otherwise there is a risk of heater unit failure, electric shock, or fire. The power cable cannot be used with electrical equipment other than the heater unit.
- Never attempt to repair the machine yourself, which is hazardous. This may pose a risk of failure or electric shock. In case of abnormalities, contact your local dealer or our service office.



- Do not use where the temperature may change suddenly or where condensation may occur.



- A number of different power cables are provided with the product. Use the power cable to suit the region where used.

Japan	China	North America, Central America	Europe	Argentina
Rated input: 15 A, 125 V Type: B	Rated input: 10 A, 250 V Type: D	Rated input: 15 A, 125 V Type: B	Rated input: 10 A, 250 V Type: D	Rated input: 10 A, 250 V Type: D

● Warning Label

Make sure you fully understand the details indicated on the various warning labels.

If any of the warning labels becomes dirty and illegible or peel off, contact your local dealer or our service office to request new warning labels.

No.	Order code	Label	Details
1	M903239		Indicates hot parts.

● Check the power cable connection

1 Check to confirm that the power cable is connected to the heater unit inlet.

- There are two inlets for optional heaters on the right side of the main unit.

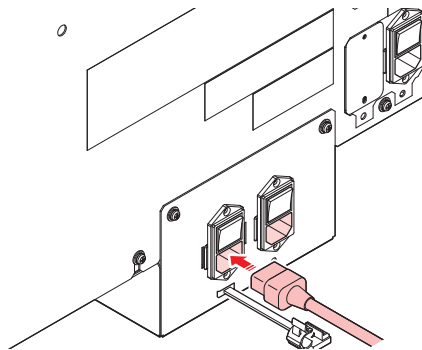

2 Check to confirm that the power plug is connected to the power outlet.

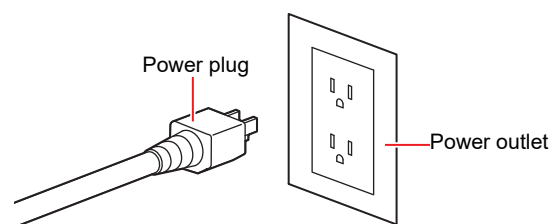

- Do not handle the power plug with wet hands. Disregarding this precaution may result in electric shock.

Using the heater

● Turn on the heater power

Turn the heater power switch to "I".

- Power switch 2: For preheater/print heater
- Power switch 3: For post-heater

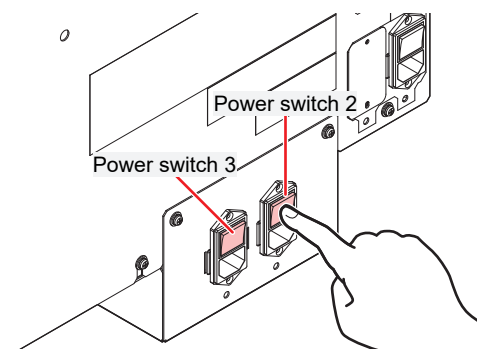

● Setting procedure

Refer to the following:

- "Setting the Heater Temperature"(P. 89)
- "Media Setting Menu"(P. 174) P. 175



- The recommended heater temperatures are as follows: PRE: 50 °C, PRINT: 45 °C, POST: 60 °C.
Alter the settings appropriately to suit the print conditions (ink and media used) to prevent media feeding problems occurring.

● Troubleshooting

Refer to the following:

- ["The heater temperature does not rise to the specified value."\(P. 256\)](#)
- ["Problems Causing Messages to Appear"\(P. 264\)](#)

Specifications (UCJV330 Heater Unit)

Item			160 size	130 size
Power supply specifications			Single-phase 100 to 120 V AC $\pm 10\%$ /12 A, single-phase 200 to 240 V AC $\pm 10\%$ /6 A, 50/60 Hz ± 1 Hz $\times 1$	
Power consumption	Max	Inlet 2	100 to 120 V AC: Max. 1,440 W, 200 to 240 V AC: Max. 1,440 W	
		Inlet 3	100 to 120 V AC: Max. 1,440 W, 200 to 240 V AC: Max. 1,100 W	
	Standard	Inlet 2	650 W	
		Inlet 3	350 W	
Available temperature setting	PRINT	20 °C to 50 °C		
	POST	20 °C to 60 °C		

*1. The figures in parentheses indicate package dimensions.

TP Ink Heater Unit

TS

Be sure to read and understand the following information before use.

● Before use



- Make sure you fully understand the following details. The same precautions apply to optional items.

- (1) "Introduction"(P. 7)
- (2) "To Ensure Safe Use"(P. 9)
- (3) "Installation Precautions"(P. 18)



- This is a high-voltage device. Avoid exposure to substances such as water, oil, or flammable solvents. Failure to follow this precaution may cause insulation breakdown and pose a risk of mechanical failure or electric shock.



- Use the power cable provided. Otherwise there is a risk of heater unit failure, electric shock, or fire. The power cable cannot be used with electrical equipment other than the heater unit.
- Never attempt to repair the machine yourself, which is hazardous. This may pose a risk of failure or electric shock. In case of abnormalities, contact your local dealer or our service office.



- Do not use where the temperature may change suddenly or where condensation may occur.



- A number of different power cables are provided with the product. Use the power cable to suit the region where used.

Japan	China	North America, Central America	Europe	Argentina
Rated input: 15 A, 125 V Type: B	Rated input: 10 A, 250 V Type: D	Rated input: 15 A, 125 V Type: B	Rated input: 10 A, 250 V Type: D	Rated input: 10 A, 250 V Type: D

● Warning Label

Make sure you fully understand the details indicated on the various warning labels.

If any of the warning labels becomes dirty and illegible or peel off, contact your local dealer or our service office to request new warning labels.

No.	Order code	Label	Details
1	M906144		Indicates hot parts.

● Check the power cable connection

- 1 Check to confirm that the power cable is connected to the heater unit inlet.

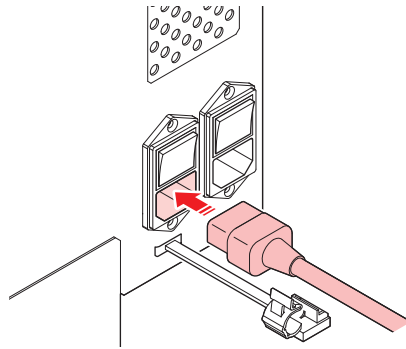

- 2 Check to confirm that the power plug is connected to the power outlet.

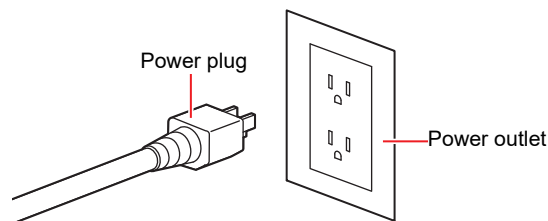

- Do not handle the power plug with wet hands. Disregarding this precaution may result in electric shock.

Using the heater

● Turn on the heater power

Turn the heater power switch to "I".

- Power switch 2: For print heater/post heater

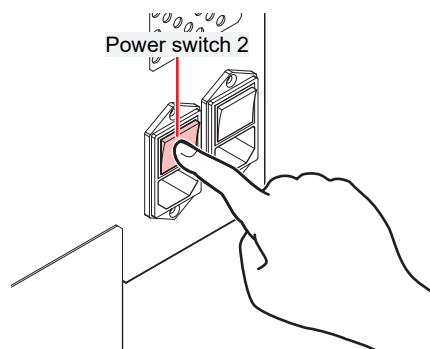

● Setting procedure

Refer to the following:

- ["Setting the Heater Temperature"\(P. 89\)](#)
- ["Media Setting Menu"\(P. 174\)](#) P. 175

● Troubleshooting

Refer to the following:

- ["The heater temperature does not rise to the specified value."\(P. 256\)](#)
- ["Problems Causing Messages to Appear"\(P. 264\)](#)

Specifications (TP Ink Heater Unit)

Item			TS330-1600
Power supply specifications			Single-phase 100 to 120 V AC $\pm 10\%$ /12 A, single-phase 200 to 240 V AC $\pm 10\%$ /6 A, 50/60 Hz ± 1 Hz $\times 1$
Power consumption	Max	Inlet 2	100 to 120 V AC: Max. 1,440 W, 200 to 240 V AC: Max. 1,440 W
	Standard	Inlet 2	400 W
Available temperature setting	PRINT		20 °C to 50 °C

9.5 LICENSE Library

Mimaki printer Firmware

Copyright ©2020 MIMAKI ENGINEERING CO.,LTD. All rights reserved.

This product contain open source software listed in the tables below.

Component	License
StarterWare for ARM® based TI Sitara Processors	BSD-TI

The following license terms and conditions shall apply to the open source software listed in the table above:

BSD-TI

Copyright (C) 2010 Texas Instruments Incorporated - <http://www.ti.com/>

Redistribution and use in source and binary forms, with or without modification, are permitted provided that the following conditions are met:

1. Redistributions of source code must retain the above copyright notice, this list of conditions and the following disclaimer.
2. Redistributions in binary form must reproduce the above copyright notice, this list of conditions and the following disclaimer in the documentation and/or other materials provided with the distribution.
3. Neither the name of Texas Instruments Incorporated nor the names of its contributors may be used to endorse or promote products derived from this software without specific prior written permission.

THIS SOFTWARE IS PROVIDED BY THE COPYRIGHT HOLDERS AND CONTRIBUTORS "AS IS" AND ANY EXPRESS OR IMPLIED WARRANTIES, INCLUDING, BUT NOT LIMITED TO, THE IMPLIED WARRANTIES OF MERCHANTABILITY AND FITNESS FOR A PARTICULAR PURPOSE ARE DISCLAIMED. IN NO EVENT SHALL THE COPYRIGHT OWNER OR CONTRIBUTORS BE LIABLE FOR ANY DIRECT, INDIRECT, INCIDENTAL, SPECIAL, EXEMPLARY, OR CONSEQUENTIAL DAMAGES (INCLUDING, BUT NOT LIMITED TO, PROCUREMENT OF SUBSTITUTE GOODS OR SERVICES; LOSS OF USE, DATA, OR PROFITS; OR BUSINESS INTERRUPTION) HOWEVER CAUSED AND ON ANY THEORY OF LIABILITY, WHETHER IN CONTRACT, STRICT LIABILITY, OR TORT (INCLUDING NEGLIGENCE OR OTHERWISE) ARISING IN ANY WAY OUT OF THE USE OF THIS SOFTWARE, EVEN IF ADVISED OF THE POSSIBILITY OF SUCH DAMAGE.

Index

A

AC adapter power plug.....	300
Adj-prs Offset	190, 260
Adjust Waste Ink Volume	242
Air PG.....	92, 179, 254
Auto Cleaning	178
Auto Maint.	26, 27, 178
Auto Media Cut.....	190
Auto Nozzle Recovery	178
Auto Power-off.....	182
Auto Power-on.....	182
Auto Remote	184
Auto-correction (DAS)	174, 265

B

Blowing fan	28, 195, 211, 230
Bottle cap	52, 53, 54

C

Cancel	33
Cap	30, 195, 196, 198, 223
Cap absorber.....	225
Cap Replacement.....	177
Capping Use Days	187
Carriage.....	26, 30, 33, 177, 195, 196, 198
Carriage Out.....	177
Clamp lever	26, 28
Clamp pressure	176
Cleaning	92, 177
Color profile	43
Connection relay cable.....	287
Copy	189, 191, 277
Corner Cut.....	190, 192
Curve Mode	190
Custody Wash	177, 213, 215
Cut Mode.....	189
Cutter for Cutting Machine	247
Cutter unit.....	26
Cutting Menu	188

Cutting slot 30

D

DAS (Dot Adjustment System) 174, 195, 196, 202

Delete MediaInfo 176

Deodorizing fan unit 183, 294

Detail Setting 176

Detect Area 188

Detect End Key Start 188

DISCLAIMERS 7

Display 33, 34

Display language 185

Drop.PosCorrect 36, 60, 95, 174

Dropouts 92, 179, 254

Drying Time 182

Drying/Exhaust Fan 183, 296, 297

Dummy cut 189

E

Ejection failures 90, 92, 177, 179, 200, 223, 250

[END/POWER] key 32, 33, 38

[ENTER] key 33

Environment Setting Menu 185

Error 33, 264

Error History 187

Exhaust fan BOX 28, 229

F

FCC 8

Feed Comp. 36, 59, 93, 174, 175

Feed Speed 176

Feeding Before Cut 183

Feeding unit 28, 74

FineCut 129

Finisher 144, 159, 160, 184, 269

Front cover 27

[FUNCTION] key 33, 36

Function Setting Menu 182

G

Grit roller 26, 31, 63

H

Half Cut	116, 247
Head Cleaning.....	33
Head height	61
Heater.....	26, 28, 32, 89, 175, 256
Heater unit.....	302, 305
Height adjustment lever.....	61

I

ID Cut Guide.....	128, 132
ID Cut	127, 132
Illumination	183
Ink absorber	47, 240
Ink bottle	29, 51, 53, 55
Ink caps	51
Ink discharge channel	195, 196, 203
Ink Eco-case.....	29, 46, 48, 49
Ink End	45, 179
Ink error	35
Ink IC chip	29, 46, 47, 50, 52, 55, 56
Ink IC chip slot.....	29, 50, 55
Ink leak check tube.....	29
Ink lever.....	29
INK NEAR-END.....	45
Ink pack	46, 47
Ink replacement.....	187
Ink status	34
Ink Supply Error.....	179
Ink Supply Maint.....	179
Ink Supply Unit	29, 47, 240
Ink wipe pad	29, 52
Inlet.....	28, 37, 296, 303, 306
Installation guide	43, 44
Installation Space	19
Interference	7
interlock.....	21
Interval Wiping.....	179
Ionizer.....	288

J

Jam sensor	26, 195, 196, 208
------------------	-------------------

[JOG] key	33
Judgment Condition	178
<hr/> K <hr/>	
Key Buzzer	185
KeyLife	186
<hr/> L <hr/>	
LAN cable	28, 40
LAN port	28
LANGUAGE	185
Light-blocking cover	29, 51, 256
List	187
Local guidance	36
LOCAL mode	33, 34
Logical Seek	182
<hr/> M <hr/>	
Machine Status Menu	187
Main power switch	28, 32, 37
Maintenance	187
Maintenance cover	26
Maintenance History	187
Maintenance liquid absorber	225
Maintenance liquid cartridge	28
Maintenance Menu	177
MAPS (Mimaki Advanced Pass System)	175
Margin	127, 183
Mark Detect	125, 127, 130, 131, 188, 277
Mark FillUp	188
Marks Sensor	136, 190, 258, 259
Media	66
Media Changer	28
Media Chute	136, 139, 140, 142
Media cutter	26, 195, 196, 206, 234
Media Edge Guides	27, 70, 239
Media feed	33
Media guides	136
Media holder	195, 196, 207, 232
Media Information	175
Media Name Change	176
Media Operation Form	176

Media Remain	176
Media Sensor	28, 31, 195, 196, 205
Media Setting Menu	174
Media stopper.....	72, 75
Media Width	176
MENU mode.....	34
Mimaki driver	43
MIST FILTER.....	196, 210, 245
MRA (Mimaki Remote Access).....	185
Multi-layer printing	87

N

NCU (Nozzle Check Unit).....	30, 195, 196, 200
Network	185
NOT-READY mode	34
Nozzle Check	177, 181
Nozzle clogging	92, 181
Nozzle Deflection	92
Nozzle Recovery	177, 179
Nozzle Wash	177, 253, 254

O

Offset.....	116
Operating Panel	26, 33
Orange Maintenance	179
Over Cut	190, 192

P

Pen line	247
Pen line rubber	247
Pen line sponge.....	247
PIN code.....	186
Pinch roller	26, 31, 58, 63, 87, 106, 231
Pinch roller guide.....	63
Platen	26, 30, 195, 196, 209
Post-heater	27, 89
Power cable.....	37, 296, 303, 306
Power outlet	37, 296, 300, 303, 306
Power plug	37, 296, 303, 306
Power Setting	182
Pre Feed.....	176
Preheater.....	89

Print Area	187
Print heater	89
Print Length	187
Print Maint.	178
Print origin	99
Printing Check	177
Proofing Light	300
pullback	175
Pullback printing	93
Pump Tube Cleaning.....	177, 203

R

RasterLink	43, 44, 97, 98, 127, 129, 148, 155, 182, 183, 258, 260
Receive buffer	101, 119, 189, 190, 258, 277
Reference guide	98, 148, 155, 260
Refresh	179
Register mark	122, 124, 125, 126, 128, 129, 188
Relay box	287
Remaining ink.....	34
Remote Control	185
REMOTE mode	33, 34
Replace Wiper	177, 187, 219
Roll guide	73
Roll holder	73, 76
Roll Wiper Remain	187

S

Sample Cut.....	190, 258, 260
Scale Adjust	190, 258
[SEL] key	33
Selection handle	74
Sensor sensitivity	188, 264, 273, 274
Setup Sub Menu.....	189
Sheet Type	190
Slit Position Adjustment.....	171, 184
Slit Position Detection	161, 184
Slitting Feed	164, 184
Smoothing Level.....	175
Space Btwn PP.	183
Space Feed Mode	183
Static-Cling Prevention Sheet Kit	291
Station	26, 30

Station Maint.	177
Status lamp	33
stopper	136
Switching hub	40
Symbols.....	9
SYSTEM HALT	33

T

Take-up SW	182
Take-up unit	27, 67, 182
Tension bar	136
Test Printing	33, 90, 177
Tightening tool.....	54
Time Set	185
Tool Change	110, 114, 189
Top Blower	183
Torque limiter	68
TxLink.....	43

U

Unit Setting	185
Unlocking pin.....	74
Up Speed	189
Usage	187
USB interface cable.....	28, 41
USB port.....	28
Use PR Number Query	183
Use Time	187
UV AdjVal	175
UV Lamp	187
UV mode	175
UV-LED lamp	26, 30, 175, 187, 199
UV-LED Unit.....	196, 246

V

Vacuum Fan	176, 190
Version	187
View Feed	183

W

Warning Label	22, 295, 302, 305
Wash Wiping	92

Waste Ink Tank	26, 179, 187, 195, 196, 242
White ink.....	91
White Maintenance.....	179
WhiteSpace Setting.....	183
Wiper	30, 100, 155, 177, 178, 195, 196, 200, 219, 257

X

X Cutter	136, 138, 151, 164, 237
XY carriage.....	136
XY clamp	136
XY Clamp Lever	136, 137
XY slitter	26, 136, 184

Y

Y cutter	136, 236
----------------	----------

Operation manual

Aug, 2024

MIMAKI ENGINEERING CO.,LTD.

2182-3 Shigeno-otsu, Tomi-shi, Nagano 389-0512 JAPAN

D203599-23-09082024

